



57-م/2021/19/ع

بحرِ ایشیائی و بحری امور

تاریخ ایشیائی برسرِ سہ ماہی

"وہسٹر ٹائٹل ٹرسٹس ایشیائی بحری امور 1968" ریسر "وہسٹر ٹائٹل ٹرسٹس ایشیائی بحری امور
 بحری امور ایشیائی بحری امور 1968" ریسر "وہسٹر ٹائٹل ٹرسٹس ایشیائی بحری امور
 بحرِ ایشیائی و بحری امور ایشیائی بحری امور ایشیائی بحری امور ایشیائی بحری امور
 تاریخ ایشیائی برسرِ سہ ماہی بحری امور ایشیائی بحری امور

بحری امور سرسہ ماہی: M19/KG/2021/07

07 ج 2021



تاریخ و دستاویز

ڈائریکٹرز

ڈائریکٹر ایس
 ڈائریکٹر ایس



ڈائریکٹر ایس
 ڈائریکٹر ایس



ڈائریکٹرز

ڈائریکٹر ایس
 ڈائریکٹر ایس



ڈائریکٹر ایس
 ڈائریکٹر ایس



ڈائریکٹر ایس
 ڈائریکٹر ایس



ڈائریکٹرز

ڈائریکٹر ایس
 ڈائریکٹر ایس



ڈائریکٹر ایس
 ڈائریکٹر ایس



ڈائریکٹر ایس
 ڈائریکٹر ایس



ڈائریکٹرز

ڈائریکٹر ایس
 ڈائریکٹر ایس



ڈائریکٹر ایس
 ڈائریکٹر ایس



ڈائریکٹر ایس
 ڈائریکٹر ایس



ڈائریکٹرز

ڈائریکٹر ایس
 ڈائریکٹر ایس



ڈائریکٹر ایس
 ڈائریکٹر ایس



دَرَجَتِ مَبْرُورِہ

1. کورس نمبر سو نمبر 5
2. درجہ نمبر سو نمبر 5
3. کورس نمبر سو نمبر 5
4. کورس نمبر سو نمبر 7
5. درجہ نمبر سو نمبر 14
6. سرٹیفکیٹ نمبر سو نمبر 15
7. کورس نمبر سو نمبر 15



20. د ډیټیلرې اړخه لخوا 46 ۽ 4 وېره سره سمون لري، ډیټیلرې اړخه لخوا د اړوندو د اړوندو سره سمون لري او د ډیټیلرې اړخه لخوا د اړوندو سره سمون لري، ډیټیلرې اړخه لخوا د اړوندو سره سمون لري او د ډیټیلرې اړخه لخوا د اړوندو سره سمون لري؛

21. د ډیټیلرې اړخه لخوا د اړوندو سره سمون لري 30 د 2020 ز. د اړوندو سره سمون لري او د ډیټیلرې اړخه لخوا د اړوندو سره سمون لري.

- "د اړوندو سره سمون لري د 1968" د اړوندو سره سمون لري او د اړوندو سره سمون لري؛

- د ډیټیلرې اړخه لخوا د اړوندو سره سمون لري، ډیټیلرې اړخه لخوا د اړوندو سره سمون لري او د ډیټیلرې اړخه لخوا د اړوندو سره سمون لري؛

- د ډیټیلرې اړخه لخوا د اړوندو سره سمون لري، ډیټیلرې اړخه لخوا د اړوندو سره سمون لري او د ډیټیلرې اړخه لخوا د اړوندو سره سمون لري؛



קובץ המכתמים והמכתבים שהתקבלו במסגרת תהליך הבחירה למועצה
המנהלית של רשות המים והביובים, 2019-2021.

28. ב-17 בדצמבר 2019, הודיעו חברי המועצה המנהלית כי הם מתכוונים
לערוך בחירה למועצה המנהלית של רשות המים והביובים, 2019-2021.
ב-17 בדצמבר 2019, הודיעו חברי המועצה המנהלית כי הם מתכוונים
לערוך בחירה למועצה המנהלית של רשות המים והביובים, 2019-2021.

29. ב-17 בדצמבר 2019, הודיעו חברי המועצה המנהלית כי הם מתכוונים
לערוך בחירה למועצה המנהלית של רשות המים והביובים, 2019-2021.
ב-17 בדצמבר 2019, הודיעו חברי המועצה המנהלית כי הם מתכוונים
לערוך בחירה למועצה המנהלית של רשות המים והביובים, 2019-2021.

30. ב-17 בדצמבר 2019, הודיעו חברי המועצה המנהלית כי הם מתכוונים
לערוך בחירה למועצה המנהלית של רשות המים והביובים, 2019-2021.
ב-17 בדצמבר 2019, הודיעו חברי המועצה המנהלית כי הם מתכוונים
לערוך בחירה למועצה המנהלית של רשות המים והביובים, 2019-2021.

5. תוצאות

ב-17 בדצמבר 2019, הודיעו חברי המועצה המנהלית כי הם מתכוונים
לערוך בחירה למועצה המנהלית של רשות המים והביובים, 2019-2021.
ב-17 בדצמבר 2019, הודיעו חברי המועצה המנהלית כי הם מתכוונים
לערוך בחירה למועצה המנהלית של רשות המים והביובים, 2019-2021.
ב-17 בדצמבר 2019, הודיעו חברי המועצה המנהלית כי הם מתכוונים
לערוך בחירה למועצה המנהלית של רשות המים והביובים, 2019-2021.



بجاء القرض - 1

دائرة التعليم والتربية - جامعة الكويت
مقره في
المنامة



بَیِّنَاتُ 2-

بَیِّنَاتُ 2- مَبْنِيَّةٌ عَلَى مَبْنِيَّةٍ وَتَحْتِهَا مَبْنِيَّةٌ



بِسْمِ اللَّهِ الرَّحْمَنِ الرَّحِيمِ

ދިވެހިސަރުކާރުގެ ގެޒެޓް



Ministry of Transport and Civil Aviation
Republic of Maldives

ޕްލޭންޕްރޮޖެކްޓްގެ ދަށުން ސަރުކާރުގެ ޖެޓް ފްލައިޕްލޭންޕްރޮޖެކްޓް
ދެއްވާ ޕްރޮސެޖަރުގެ ޖެޓް ފްލައިޕްލޭންޕްރޮޖެކްޓް

ޖެޓް ފްލައިޕްލޭންޕްރޮޖެކްޓްގެ ދަށުން ސަރުކާރުގެ ޖެޓް ފްލައިޕްލޭންޕްރޮޖެކްޓް 1968 ގައި

ޕްރޮސެޖަރުގެ ޖެޓް ފްލައިޕްލޭންޕްރޮޖެކްޓް ޖެޓް ފްލައިޕްލޭންޕްރޮޖެކްޓް

1. ޖެޓް ފްލައިޕްލޭންޕްރޮޖެކްޓް

"ޖެޓް ފްލައިޕްލޭންޕްރޮޖެކްޓްގެ ދަށުން ސަރުކާރުގެ ޖެޓް ފްލައިޕްލޭންޕްރޮޖެކްޓް 1968 ގައި"
1968 ގައި ޖެޓް ފްލައިޕްލޭންޕްރޮޖެކްޓްގެ ދަށުން ސަރުކާރުގެ ޖެޓް ފްލައިޕްލޭންޕްރޮޖެކްޓް ޖެޓް ފްލައިޕްލޭންޕްރޮޖެކްޓް
ޖެޓް ފްލައިޕްލޭންޕްރޮޖެކްޓްގެ ދަށުން ސަރުކާރުގެ ޖެޓް ފްލައިޕްލޭންޕްރޮޖެކްޓް ޖެޓް ފްލައިޕްލޭންޕްރޮޖެކްޓް

2. ޖެޓް ފްލައިޕްލޭންޕްރޮޖެކްޓްގެ ދަށުން ސަރުކާރުގެ ޖެޓް ފްލައިޕްލޭންޕްރޮޖެކްޓް

ޕްލޭންޕްރޮޖެކްޓްގެ ދަށުން ސަރުކާރުގެ ޖެޓް ފްލައިޕްލޭންޕްރޮޖެކްޓް

3. ޖެޓް ފްލައިޕްލޭންޕްރޮޖެކްޓްގެ ދަށުން ސަރުކާރުގެ ޖެޓް ފްލައިޕްލޭންޕްރޮޖެކްޓް

"ޖެޓް ފްލައިޕްލޭންޕްރޮޖެކްޓްގެ ދަށުން ސަރުކާރުގެ ޖެޓް ފްލައިޕްލޭންޕްރޮޖެކްޓް 1968 ގައި"
1968 ގައި ޖެޓް ފްލައިޕްލޭންޕްރޮޖެކްޓްގެ ދަށުން ސަރުކާރުގެ ޖެޓް ފްލައިޕްލޭންޕްރޮޖެކްޓް ޖެޓް ފްލައިޕްލޭންޕްރޮޖެކްޓް
ޖެޓް ފްލައިޕްލޭންޕްރޮޖެކްޓްގެ ދަށުން ސަރުކާރުގެ ޖެޓް ފްލައިޕްލޭންޕްރޮޖެކްޓް ޖެޓް ފްލައިޕްލޭންޕްރޮޖެކްޓް
ޖެޓް ފްލައިޕްލޭންޕްރޮޖެކްޓްގެ ދަށުން ސަރުކާރުގެ ޖެޓް ފްލައިޕްލޭންޕްރޮޖެކްޓް ޖެޓް ފްލައިޕްލޭންޕްރޮޖެކްޓް
ޖެޓް ފްލައިޕްލޭންޕްރޮޖެކްޓްގެ ދަށުން ސަރުކާރުގެ ޖެޓް ފްލައިޕްލޭންޕްރޮޖެކްޓް ޖެޓް ފްލައިޕްލޭންޕްރޮޖެކްޓް
ޖެޓް ފްލައިޕްލޭންޕްރޮޖެކްޓްގެ ދަށުން ސަރުކާރުގެ ޖެޓް ފްލައިޕްލޭންޕްރޮޖެކްޓް ޖެޓް ފްލައިޕްލޭންޕްރޮޖެކްޓް
ޖެޓް ފްލައިޕްލޭންޕްރޮޖެކްޓްގެ ދަށުން ސަރުކާރުގެ ޖެޓް ފްލައިޕްލޭންޕްރޮޖެކްޓް ޖެޓް ފްލައިޕްލޭންޕްރޮޖެކްޓް

අධ්‍යක්ෂ ජනරාල්ගේ දැන්වීම:

"1968 වර්ෂයේ පාරාමිතික අභ්‍යන්තර භාණ්ඩ මාරු කිරීමේ පනත" යන නමින් 1968 අංක 18 වන නියෝගයක් ප්‍රකාශ කිරීමේදී අදාළ නියෝගයේ 18 වන කොටසේ පිටුව 18 වන සටහන් කිරීමේදී වෙනස් කිරීම් සිදු කිරීම සම්බන්ධව ප්‍රකාශයක් ප්‍රකාශ කළේය.

අධ්‍යක්ෂ ජනරාල්ගේ දැන්වීම:

"1968 වර්ෂයේ පාරාමිතික අභ්‍යන්තර භාණ්ඩ මාරු කිරීමේ පනත" යන නමින් 1968 අංක 18 වන නියෝගයක් ප්‍රකාශ කිරීමේදී අදාළ නියෝගයේ 18 වන කොටසේ පිටුව 18 වන සටහන් කිරීමේදී වෙනස් කිරීම් සිදු කිරීම සම්බන්ධව ප්‍රකාශයක් ප්‍රකාශ කළේය.

අධ්‍යක්ෂ ජනරාල්ගේ දැන්වීම:

"1968 වර්ෂයේ පාරාමිතික අභ්‍යන්තර භාණ්ඩ මාරු කිරීමේ පනත" යන නමින් 1968 අංක 18 වන නියෝගයක් ප්‍රකාශ කිරීමේදී අදාළ නියෝගයේ 18 වන කොටසේ පිටුව 18 වන සටහන් කිරීමේදී වෙනස් කිරීම් සිදු කිරීම සම්බන්ධව ප්‍රකාශයක් ප්‍රකාශ කළේය.

අධ්‍යක්ෂ ජනරාල්ගේ දැන්වීම:

"1968 වර්ෂයේ පාරාමිතික අභ්‍යන්තර භාණ්ඩ මාරු කිරීමේ පනත" යන නමින් 1968 අංක 18 වන නියෝගයක් ප්‍රකාශ කිරීමේදී අදාළ නියෝගයේ 18 වන කොටසේ පිටුව 18 වන සටහන් කිරීමේදී වෙනස් කිරීම් සිදු කිරීම සම්බන්ධව ප්‍රකාශයක් ප්‍රකාශ කළේය.

بِسْمِ اللّٰهِ الرَّحْمٰنِ الرَّحِیْمِ



ދިވެހިސަރުކާރުގެ ގެޒެޓް ގައި ވާހަކަ ދުވައިވާ
ގައުމީ ދިވެހިރާއްޖޭގެ ދުވަސް

ނުވަނަ ބައި: 25-G1/472/2020/31

ދިވެހިސަރުކާރުގެ ގެޒެޓް ގައި ވާހަކަ ދުވައިވާ ގައުމީ ދުވަސް ބޭނުންކުރާ ގައުމީ ދުވަސްތަކުގެ
ލިސްޓު ދެކޮޅަށް ފަދަ ޖަމާއަތްތަކުގެ ފަރާތުން

ފަދަ ސަފުޞްލާ ހަދަން ދެންނަވަން ބޭނުންކުރާނެއެވެ.

އިތުރު ފޮތްތަކާއި ސަރުކާރުގެ ގެޒެޓް ގައި 472/25/2020/8 (7 ވަނަ ބައި 2020) ސަފުޞްލާ ފޮތްތަކުގެ ފަރާތުން

"އިތުރު ފޮތްތަކާއި ސަރުކާރުގެ ގެޒެޓް ގައި 1968" ގައި "ގައުމީ ދުވަސް ބޭނުންކުރާ ގައުމީ ދުވަސްތަކުގެ

ލިސްޓު ބޭނުންކުރާ ގައުމީ ދުވަސް 1968" ގައި ހިމެނޭ ގައުމީ ދުވަސްތަކުގެ ފަރާތުން ފޮތްތަކުގެ ފަރާތުން

ފަދަ ސަފުޞްލާ ހަދަން ބޭނުންކުރާ ގައުމީ ދުވަސް ބޭނުންކުރާ ގައުމީ ދުވަސްތަކުގެ ފަރާތުން

އިތުރު ފޮތްތަކާއި ސަރުކާރުގެ ގެޒެޓް ގައި ވާހަކަ ދުވައިވާ ގައުމީ ދުވަސް

16 ސަފުޞްލާ 1442

4 ރިޖިސްޓްރޭޝަން 2020

ފަރާތުގެ ނަންމު
Adam Farid
ފަރާތުގެ ނަންމު
ފަރާތުގެ ނަންމު

ދިވެހިސަރުކާރުގެ ގެޒެޓް ގައި ވާހަކަ ދުވައިވާ ގައުމީ ދުވަސް ބޭނުންކުރާ ގައުމީ ދުވަސްތަކުގެ
ލިސްޓު ދެކޮޅަށް ފަދަ ޖަމާއަތްތަކުގެ ފަރާތުން

ފަދަ ސަފުޞްލާ ހަދަން ބޭނުންކުރާނެއެވެ.

**VIENNA CONVENTION ON
ROAD SIGNS AND SIGNALS
1968**

Disclaimer

The present publication, which contains consolidated versions of the Vienna Convention on Road Signs and Signals, the European Agreement supplementing the Convention and its additional Protocol, has been prepared for information and reference purposes.

It is not a legal document and is not intended to substitute the official legal texts of the Convention, the European Agreement, its additional Protocol and the amendments to them. The symbols of the official texts are provided on page viii of the present publication.

| |
|---------------|
| ECE/TRANS/196 |
|---------------|

| |
|------------------------------|
| UNITED NATIONS PUBLICATION |
| <i>Sales No. E.07.VIII.7</i> |
| ISBN: 978-92-1-116973-7 |

Foreword

As road users in our everyday life, we tend to take for granted the system of road traffic rules, signs and signals, which has been developed to regulate road traffic and avoid accidents. However, a considerable amount of research and planning has gone into this system, which has been developed gradually since the start of motorization in the early 1900s and more intensively since the Second World War.

Efficient, safe and sustainable road traffic requires adequate regulations for the construction of roads, for the manufacturing of vehicles and for traffic on the roads. Given the trans-frontier dimension of road traffic, it is essential that such regulations be internationally harmonized on the basis of internationally agreed regulations.

The UNECE has, since its creation in 1947, developed international regulations on the various components of road traffic: the road, the vehicle and road users. Incorporated into legally binding agreements and conventions, those regulations are regularly updated in order to keep them up to best practices and the best available technologies.

The implementation in UNECE countries of these agreements and conventions has greatly contributed to lowering the number of people killed on UNECE roads despite a sharp increase in road traffic. However, while this evolution is encouraging, there is no room for complacency. In 2004, more than 140,000 people lost their lives and about 5 million more were injured on the road in the UNECE region. In the whole world, figures are daunting: about 1.2 million people die and between 20 to 40 million more are injured every year in road accidents, of which about 80% in low- and middle-income countries. In addition to personal tragedies and tremendous human suffering, road accidents are estimated to cost to society about US\$ 500 billion a year worldwide.

A most basic requirement to reduce these figures drastically is to put in place appropriate road traffic legislation that is based on the relevant international conventions. In resolution A/RES/60/5, the United Nations General Assembly encouraged Member States to adhere to the UN Conventions on Road Signs and Signals and on Road Traffic in order to ensure a high level of road safety in their countries, and also encouraged them to strive to reduce road traffic injuries and mortality in order to achieve the Millennium Development Goals.

The present publication contains consolidated versions of the Vienna Convention on Road Signs and Signals, the European Agreement supplementing the Convention, and its additional Protocol, incorporating all the amendments that have been prepared and adopted by the UNECE Working Party on Road Traffic Safety (WP.1) in order to make their safety provisions more stringent.

I believe that, if applied, these legal instruments will contribute to preventing many deaths and injuries on the world's roads and I encourage all United Nations Member States that have not yet done so to adhere to and implement them as soon as possible. It is often said that time is gold. In this matter, time is also human lives. Let's act quickly to save many lives



Marek Belka
Executive Secretary
United Nations Economic Commission for Europe

CONTENTS

| | <i>Page</i> |
|-----------------------------------------------------------------------------------------------------------------------------------------------|-------------|
| Disclaimer | ii |
| Foreword | iii |
| Historical background | vii |
| Part I Convention on Road Signs and Signals, of 1968 (Vienna Convention) | 1 |
| Chapter I General Provisions (<i>Articles 1 to 4</i>) | 3 |
| Chapter II Road Signs (<i>Articles 5 to 22</i>) | 7 |
| Chapter III Traffic Light Signals (<i>Articles 23 to 24</i>) | 15 |
| Chapter IV Road Markings (<i>Articles 25 to 30</i>) | 18 |
| Chapter V Miscellaneous (<i>Articles 31 to 36</i>) | 21 |
| Chapter VI Final Provisions (<i>Articles 37 to 48</i>) | 23 |
| ANNEXES | |
| 1. Road Signs | 31 |
| 2. Road Markings | 57 |
| Diagrams | 63 |
| 3. Reproduction in Colour of Signs, Symbols and Panels Referred to in Annex 1 ... | 83 |
| Part II European Agreement supplementing the 1968 Convention on Road Signs and Signals | 109 |
| Text of the European Agreement | 111 |
| Annex to the European Agreement | 117 |
| Annex- Appendix (Models of Road Signs)..... | 129 |
| Part III Protocol on Road Markings, Additional to the European Agreement Supplementing the Convention on Road Signs and Signals of 1968 | 133 |
| Text of the Protocol | 135 |
| Annex to the Protocol | 141 |
| Diagrams | 151 |
| Part IV List of Contracting Parties to the 1968 Convention on Road Signs and Signals .. | xx |
| Declarations and reservations | xx |

CONTENTS *(continued)*

| | | |
|---------|--------------------------------------------------------------------------------------------------------------------------------------------------------------|----|
| Part V | List of Contracting Parties to the European Agreement supplementing the 1968 Vienna Convention on Road Signs and Signals..... | XX |
| | Declarations and reservations | XX |
| Part VI | List of Contracting Parties to the Protocol on Road Markings, Additional to the European Agreement Supplementing the Convention on Road Signs and Signals | XX |
| | Declarations and reservations | XX |
| | Alphabetical index of the Vienna Convention on Road Signs and Signals, the European Agreement Supplementing the Convention and its Additional Protocol | XX |

Historical Background

The origins of international legislation on road traffic may be traced back to the International Convention on Motor Traffic concluded in Paris on 11 October 1909. The problems of motor vehicle construction, of admission to international traffic and of signs and signals were already dealt with, as regards the essentials, in that Convention.

The expansion of motor vehicle traffic led to the conclusion in Paris, on 24 April 1926, of two new conventions which were intended to amend and amplify the 1909 Convention: the International Convention relating to Road Traffic and the International Convention relating to Motor Traffic. Various texts had served as a basis for these Conventions; most particularly the draft prepared by the League of Nations Special Committee of Enquiry on Road Traffic, a draft by the French Government and a draft by the Swedish Government aimed mainly at the standardization of certain danger warning signs.

The 1926 Convention did not deal exhaustively with road signs and signals. To fill this gap, a Convention concerning the Unification of Road Signs was concluded in Geneva on 30 March 1931.

In December 1943, the States of the Two Americas, meeting under the auspices of the Pan American Union in Washington, concluded a Convention on the Regulation of Inter-American Automotive Traffic. This regional Convention did not deal with signs and signals.

In 1948, noting that the Conventions of 1926 and 1931 were obsolete, the United Nations Economic and Social Council, by resolution 147 B (VII) of 28 August, called for a United Nations Conference on Road and Motor Transport to be convened in Geneva. That Conference based its work on a draft convention prepared by the Inland Transport Committee of the United Nations Economic Commission for Europe and on the 1943 Convention on the Regulation of Inter-American Automotive Traffic. The work of the Conference resulted, in 1949, in the conclusion of a Convention on Road Traffic and a Protocol on Road Signs and Signals.

The first of these instruments terminated and replaced, in relations between the Contracting States, the 1926 Conventions and the 1943 Inter-American Convention. The two instruments provided for a procedure enabling them to be amended without any need for calling a conference, on condition that two thirds of the Contracting States agreed. The procedure was initiated for both the Convention and the Protocol, but bore fruit only in the case of the Protocol, which was amended with effect as from 22 October 1964.

In 1964, the Economic and Social Council noted that the procedure for revision without convening a conference had failed so far as concerned the 1949 Convention, although greater uniformity of national regulations governing road traffic and the equipment of motor vehicles was needed, and that the 1949 Protocol, too, should be amended more radically than had been possible by that procedure.

By resolution 1034 (XXXVII), the Council decided that in preparation for a conference, detailed technical studies should be undertaken with a view to the preparation of a revised draft convention on road traffic and on standard technical specifications for vehicles, and also of a draft instrument on road signs and signals and on road markings. It was stipulated that the regional economic commissions, in particular, should take part in that work.

In the following year, after taking note of the draft texts thus prepared by the Secretary-General (E/3998 and Add.1, and E/3999 and Add.1), the Economic and Social Council decided that a conference should be convened in order to prepare a new convention on road traffic to replace the 1949 Convention, and either another convention or an optional protocol on road signs and signals (resolution 1082 (XXXIX)).

In July 1966, the Economic and Social Council made the final arrangements for the preparation of the conference by resolution 1129 (XLI), which was to be amended the following year on certain points of detail (resolution 1203 (XLII)). More particularly, it decided that two draft conventions should be prepared as a basis for the work of the Conference (E/CONF.56/1 and Add.1 and Corr.1 and E/CONF.56/3 and Add.1 and Corr.1), that these texts should be circulated to Governments and to international organizations concerned so that they could make, respectively, such proposals or suggestions for amendments as they deemed necessary.

The preparatory work, in particular the drafting of the texts, was undertaken by the predecessor of the current Working Group on Road Traffic Safety (WP.1) of the United Nations Economic Commission for Europe (UNECE).

The Conference, which gathered together countries from the entire world, was held from 7 October to 8 November 1968 in Vienna and ended on 8 November with the opening ceremony for signature of the two texts adopted, namely: the Convention on Road Signs and Signals (E/CONF.56/17/Rev.1) and the Convention on Road Traffic (E/CONF.56/16/Rev.1). Thirty-one countries signed the Convention on Road Signs and Signals that day. The Convention entered into force on 6 June 1978 and has 56 Contracting Parties, at the date of 1 July 2007.

Upon its entry into force, the 1968 Convention, in accordance with Article 40, terminates and replaces, in relations between Contracting Parties, previous road signs and signals Conventions and notably the Protocol on Road Signs and Signals of 1949.

Following the opening for signature of the Vienna Convention on Road Signs and Signals, the Inland Transport Committee (ITC) of the Economic Commission for Europe, considering that it was necessary to achieve greater uniformity in the rules governing road signs and signals in Europe, asked the UNECE Group of Experts on Road Traffic Safety to prepare a draft Agreement supplementing the Vienna Convention. The final text of that Agreement was approved by the Inland Transport Committee on 1 May 1971 (see document E/ECE/812-E/ECE/TRANS/566) and was opened for signature the same day. The Agreement entered into force on 3 August 1979 and on 1 July 2007 it had twenty-nine Contracting Parties. This Agreement was supplemented on 1 March 1973 by a Protocol on Road Markings, which entered into force on 25 April 1985. This Protocol has twenty-four Contracting Parties, at the date of 1 July 2007.

It is of course necessary to adapt these texts periodically in order to take into account technological advances and to address the growing demand from society in the areas of road safety and protection of the environment. This is the reason why the WP.1 of the UNECE, which is the only permanent Working Party in the United Nations system dealing with road safety, has proposed several updates to the Convention on Road Signs and Signals, the European Agreement supplementing the Convention and its additional Protocol, which have resulted in major amendments.

This was the case with two lots of amendments to the Convention (see documents ECE/TRANS/90/Rev.2* and TRANS/WP.1/2003/3/Rev.4) and the European Agreement (see documents ECE/TRANS/92/Rev.2** and TRANS/WP.1/2003/4/Rev.4), which respectively entered into force in November 1995 and in March 2006, and one amendment to the Protocol additional to the European Agreement (see document ECE/TRANS/WP.1/2003/5/Rev.4), which entered into force in March 2006.

The two Vienna Conventions on Road Signs and Signals and on Road Traffic, which have a global scope, the European Agreements supplementing them, and the Protocol on Road

* A text of the Convention incorporating these amendments has been previously published under the symbol E/CONF.56/17/Rev.1/Amend.1.

** A text of the Agreement incorporating these amendments has been previously published under the double symbol E/ECE/812/Amend.1-E/ECE/TRANS/566/Amend.1.

Markings, additional to the European Agreement supplementing the Convention on Road Signs and Signals, are important legal tools enabling not only the facilitation of trade and transport through harmonized rules, but also the development of road safety policies aimed at the reduction of the number of road crashes and victims. The more countries adhere to these Conventions, the more road safety will prevail.

PART I

CONVENTION ON ROAD SIGNS AND SIGNALS

DONE AT VIENNA ON 8 NOVEMBER 1968

*(Consolidated version)**

* Including the amendments to the Convention which entered into force on 30 November 1995 (marked in the margin with a single line) and the amendments which entered into force on 28 March 2006 (marked in the margin with a double line)

CONVENTION ON ROAD SIGNS AND SIGNALSThe Contracting Parties,

Recognizing that international uniformity of road signs, signals and symbols and of road markings is necessary in order to facilitate international road traffic and to increase road safety,

Have agreed upon the following provisions:

Chapter I**GENERAL PROVISIONS****ARTICLE 1**Definitions

For the purpose of this Convention, the following expressions shall have the meanings hereby assigned to them:

(a) The "domestic legislation" of a Contracting Party means the entire body of national or local laws and regulations in force in the territory of that Contracting Party;

(b) "Built-up area" means an area with entries and exits specially sign-posted as such, or otherwise defined in domestic legislation¹;

² See footnote

(c) "Road" means the entire surface of any way or street open to public traffic;

(d) "Carriageway" means the part of a road normally used by vehicular traffic; a road may comprise several carriageways clearly separated from one another by, for example, a dividing strip or a difference of level;

(e) "Lane" means any one of the longitudinal strips into which the carriageway is divisible, whether or not defined by longitudinal road markings, which is wide enough for one moving line of motor vehicles other than motor cycles;

(e) bis. "Cycle lane" means a part of a carriageway designated for cycles. A cycle lane is distinguished from the rest of the carriageway by longitudinal road markings.

(e) ter. "Cycle track" means an independent road or part of a road designated for cycles, signposted as such. A cycle track is separated from other roads or other parts of the same road by structural means.

(f) "Intersection" means any level crossroad, junction or fork, including the open areas formed by such crossroads, junctions or forks;

(g) "Level-crossing" means any level intersection between a road and a railway or tramway track with its own track formation;

(h) "Motorway" means a road specially designed and built for motor traffic, which does not serve properties bordering on it, and which:

¹ See also point 3, sub-paragraph (b) of the Annex of the European Agreement.

² Additional definition introduced in the Annex of the European Agreement (see point 3).

- (i) Is provided, except at special points or temporarily, with separate carriageways for the two directions of traffic, separated from each other either by a dividing strip not intended for traffic or, exceptionally, by other means;
 - (ii) Does not cross at level with any road, railway or tramway track, or footpath; and,
 - (iii) Is specially sign-posted as a motorway;
- (i) A vehicle is said to be:
- (i) "Standing" if it is stationary for the time needed to pick up or set down persons or to load or unload goods; and
 - (ii) "Parked" if it is stationary for any reason other than the need to avoid interference with another road-user or collision with an obstruction or to comply with traffic regulations, and if the period during which the vehicle is stationary is not limited to the time needed to pick up or set down persons or goods;

Nevertheless, it shall be open to Contracting Parties to regard as "standing" any vehicle which is stationary within the meaning of subparagraph (ii) above for a period not exceeding that fixed by domestic legislation, and to regard as "parked" any vehicle which is stationary within the meaning of subparagraph (i) above for a period exceeding that fixed by domestic legislation;

(j) "Cycle" means any vehicle which has at least two wheels and is propelled solely by the muscular energy of the persons on that vehicle, in particular by means of pedals or hand-crank;

(k) "Moped" means any two-wheeled or three-wheeled vehicle which is fitted with an internal combustion engine having a cylinder capacity not exceeding 50 cc and a maximum design speed not exceeding 50 km (30 miles) per hour. Contracting Parties are free, however, not to regard as mopeds, under their domestic legislation, vehicles which do not have the characteristics of a cycle with respect to their use, in particular the characteristic that they can be propelled by pedals, or whose maximum design speed, whose mass, or certain of whose engine characteristics exceed certain limits. Nothing in this definition shall be construed as preventing Contracting Parties from treating mopeds exactly as cycles in applying the provisions of their domestic legislation regarding road traffic;

(l) "Motor cycle" means any two-wheeled vehicle, with or without a side-car, which is equipped with a propelling engine. Contracting Parties may also treat as motor cycles in their domestic legislation three-wheeled vehicles whose unladen mass does not exceed 400 kg. The term "motor cycle" does not include mopeds, although Contracting Parties may, provided they make a declaration to this effect in conformity with Article 46, paragraph 2, of this Convention, treat mopeds as motor cycles for the purposes of the Convention³;

(m) "Power-driven vehicle" means any self-propelled road vehicle, other than a moped in the territories of Contracting Parties which do not treat mopeds as motor cycles, and other than a rail-borne vehicle;

(n) "Motor vehicle" means any power-driven vehicle which is normally used for carrying persons or goods by road or for drawing on the road, vehicles used for the carriage of persons or goods. This term embraces trolley-buses, that is to say, vehicles connected to an electric conductor and not rail-borne. It does not cover vehicles, such as agricultural tractors, which are

³ See also point 3, sub-paragraph l) of the Annex of the European Agreement.

only incidentally used for carrying persons or goods by road or for drawing, on the road, vehicles used for the carriage of persons or goods;

(o) "Trailer" means any vehicle designed to be drawn by a power-driven vehicle and includes semi-trailers;

(p) "Semi-trailer" means any trailer designed to be coupled to a motor vehicle in such a way that part of it rests on the motor vehicle and that a substantial part of its mass and of the mass of its load is borne by the motor vehicle;

(q) "Driver" means any person who drives a motor vehicle or other vehicle (including a cycle), or who guides cattle, singly or in herds, or flocks or draught, pack or saddle animals on a road;

(r) "Permissible maximum mass" means the maximum mass of the laden vehicle declared permissible by the competent authority of the State in which the vehicle is registered;

(s) "Laden mass" means the actual mass of the vehicle as loaded, with the crew and passengers on board;

(t) "Direction of traffic" and "appropriate to the direction of traffic" mean the right-hand side if, under domestic legislation, the driver of a vehicle must allow an oncoming vehicle to pass on his left; otherwise these expressions mean the left-hand side;

(u) The requirement that a driver shall "give way" to other vehicles means that he must not continue or resume his advance or manoeuvre if by so doing he might compel the drivers of other vehicles to change the direction or speed of their vehicles abruptly.

(v) *See footnote 4*

ARTICLE 2

Annexes to the Convention

The annexes to this Convention, namely:

Annex 1: Road signs;

Section A: Danger warning signs;

Section B: Priority signs;

Section C: Prohibitory or restrictive signs;

Section D: Mandatory signs;

Section E: Special regulation signs;

Section F: Information, facilities or service signs;

Section G: Direction, position or indication signs;

Section H: Additional panels;

Annex 2: Road markings;

⁴ Additional definition introduced in the Annex of the European Agreement (see point 3).

Annex 3: Reproduction in colour of signs, symbols and panels referred to in Annex 1;
are integral parts of this Convention.

ARTICLE 3

Obligations of the Contracting Parties

1. (a) The Contracting Parties to this Convention accept the system of road signs, signals and symbols and road markings described herein and undertake to adopt it as soon as possible. To this end,

- (i) Where this Convention prescribes a sign, symbol or marking for signifying a certain rule or conveying certain information to road-users, the Contracting Parties undertake, subject to the time-limits specified in paragraphs 2 and 3 of this Article, not to use any other sign, symbol or marking for signifying that rule or conveying that information;
- (ii) Where this Convention does not prescribe a sign, symbol or marking for signifying a certain rule or conveying certain information to road-users, it shall be open to the Contracting Parties to use for these purposes any sign, symbol or marking they wish, provided that such sign, symbol or marking is not assigned a different meaning in this Convention and provided that it conforms to the system prescribed by this Convention.

(b) With a view to improving traffic control techniques, and having regard to the usefulness of carrying out experiments before proposing amendments to this Convention, it shall be open to Contracting Parties to derogate from the provisions of this Convention, for experimental purposes and temporarily, on certain sections of road.

2. Contracting Parties undertake to replace or supplement, not later than four years from the date of entry into force of this Convention in their territories, any sign, symbol, installation or marking which, although it has the characteristics of a sign, symbol, installation or marking belonging to the system prescribed by this Convention, is used with a different meaning from that assigned to it in this Convention.

3. Contracting Parties undertake to replace, within 15 years from the date of entry into force of this Convention in their territories, any sign, symbol, installation or marking which does not conform to the system prescribed in this Convention. During this period, in order to familiarize road-users with the system prescribed in this Convention, previous signs and symbols may be retained beside those prescribed in this Convention⁵.

4. Nothing in this Convention may be construed as requiring the Contracting Parties to adopt all the types of sign and marking prescribed in this Convention. On the contrary, Contracting Parties shall limit the number of types of sign or marking they adopt to what is strictly necessary.

ARTICLE 4

The Contracting Parties undertake that it shall be prohibited:

(a) To affix to a sign, to its support or to any other traffic control device anything not related to the purpose of such sign or device; if, however, Contracting Parties or sub-divisions thereof authorize a non-profit-making association to install informative signs, they may permit the emblem of that association to appear on the sign or on its support provided this does not make it less easy to understand the sign;

⁵ See also point 4 of the Annex of the European Agreement.

(b) To install any board, notice, marking or device which might be confused with signs or other traffic control devices, might render them less visible or effective, or might dazzle road-users or distract their attention in a way prejudicial to traffic safety.

Chapter II

ROAD SIGNS

ARTICLE 5

1. The system prescribed in this Convention differentiates between the following classes of road signs:

(a) Danger warning signs: these signs are intended to warn road-users of a danger on the road and to inform them of its nature;

(b) Regulatory signs: these signs are intended to inform road-users of special obligations, restrictions or prohibitions with which they must comply; they are subdivided into:

- (i) Priority signs;
- (ii) Prohibitory or restrictive signs;
- (iii) Mandatory signs;
- (iv) Special regulation signs;

(c) Informative signs: these signs are intended to guide road-users while they are travelling or to provide them with other information which may be useful; they are subdivided into:

- (i) Information, facilities or service signs;
- (ii) Direction, position or indication signs;
 - Advance direction signs;
 - Direction signs;
 - Road identification signs;
 - Place identification signs;
 - Confirmatory signs;
 - Indication signs;
- (iii) Additional panels.

2. Where this Convention allows a choice between several signs or several symbols,

(a) Contracting Parties undertake to adopt only one of such signs or symbols for the whole of their territories;

(b) Contracting Parties shall endeavour to reach regional agreements on the same choice;

(c) The provisions of Article 3, paragraph 3, of this Convention shall apply to signs and symbols of the types which are not chosen.

ARTICLE 6

1. Signs shall be so placed that the drivers for whom they are intended can recognize them easily and in time. They shall normally be placed on the side of the road appropriate to the direction of traffic; they may, however, be placed or repeated above the carriageway. Any sign placed on the side of the road appropriate to the direction of traffic shall be repeated above or on the other side of the carriageway if local conditions are such that it might not be seen in time by the drivers for whom it is intended.

2. All signs shall apply to the drivers from whom they are intended over the whole width of the carriageway open to traffic. However, signs may be made to apply to only one or to several lanes of the carriageway when lanes are defined by longitudinal markings.

In this case, one of the following three options shall be used:

(a) The sign with, if necessary, the addition of a vertical arrow shall be placed above the lane concerned, or

(b) The sign will be placed on the nearside edge of the carriageway when the road markings indicate without doubt that the sign applies solely to the traffic lane on the nearside of the carriageway and that the only purpose of this sign is to confirm a local regulation already indicated by means of road markings, or

(c) Signs E, 1 or E, 2 described in Annex 1, section E, subsection II, paragraphs 1 and 2 to this Convention or signs G, 11 and G, 12 described in Annex 1, section G, subsection V, paragraphs 1 and 2 will be placed on the edge of the carriageway.

3. Where in the opinion of competent authorities a sign would be ineffective if placed on the verge of a road with separated carriageways, it may be placed on the dividing strip and in this case need not be repeated on the verge.

4.⁶ It is recommended that domestic legislation should provide:

(a) That signs shall be so placed that they do not obstruct vehicular traffic on the carriageway, and, if placed on the verges, obstruct pedestrians as little as possible. The difference in level between the carriageway on the side where a sign is placed and the lower edge of the sign shall be as uniform as possible for signs of the same class on the same route;

(b) That the dimensions of sign panels shall be such that the sign is easily visible for a distance and can be easily understood by a person approaching it; subject to the provisions of subparagraph (c) of this paragraph, these dimensions shall be adapted to the normal speed of vehicles;

(c) That the dimensions of danger warning signs and of regulatory signs (except special regulation signs) shall be standardized in the territory of each Contracting Party.

As a general rule, there shall be four sizes for each type of sign: small, normal, large and very large. Small signs shall be used where conditions do not permit the use of normal signs or where traffic can only move slowly; they may also be used to repeat a preceding sign. Large signs shall be used on very wide roads carrying high-speed traffic. Very large signs shall be used on roads carrying very high-speed traffic, such as motorways.

ARTICLE 7

1. It is recommended that domestic legislation provide that, in order to make them more visible and legible at night, road signs, in particular danger warning signs, regulatory signs and

⁶ See also point 5 of the Annex of the European Agreement.

direction signs shall be lighted or retroreflective, provided that this does not result in road users being dazzled.⁷

2. Contracting Parties may also allow the use of fluorescent materials; in this case they shall define which signs may make use of these materials.

3. Domestic legislation should draw up rules for the use of lighted, retroreflective and fluorescent signs. It should also specify the situations in which each class of retroreflective materials shall be used.

4. Dark or light graphic elements of different colours in the signs may be differentiated by means of contrasting light or dark narrow strips respectively.

5. Nothing in this Convention shall prohibit the use, for conveying information, warnings or rules applying only at certain times or on certain days, of signs which are visible only when the information they convey is relevant.

ARTICLE 8

1. In order to facilitate international understanding of signs, the system of signs and signals prescribed in this Convention is based on the use of shapes, and colours characteristic of each class of sign and, wherever possible, on the use of graphic symbols rather than inscriptions. Where Contracting Parties consider it necessary to modify the symbols prescribed, the modifications made shall not alter their essential characteristics.

1. *bis.* In cases where variable message signs are used, the inscriptions and symbols reproduced on them must also conform to the system of signs and signals prescribed in this Convention. When, however, the technical requirements of a given type of system of signs and signals so warrant, particularly so as to ensure satisfactory legibility, and provided that no error of interpretation is possible, the prescribed dark-coloured signs or symbols may appear in a light colour, light-coloured backgrounds then being replaced by dark backgrounds. The red colour of the symbol of a sign and its border shall not be changed.

2. Contracting Parties wishing to adopt, in accordance with Article 3, paragraph 1 (a) (ii), of this Convention, any sign or symbol not prescribed in this Convention shall endeavour to secure regional agreement on such new sign or symbol.

3. Nothing in this Convention shall prohibit the addition, mainly in order to facilitate the interpretation of signs, of an inscription in a rectangular panel below the sign or in a rectangular panel containing the sign; such an inscription may also be placed on the sign itself, if this does not make the sign more difficult to understand for drivers who cannot understand the inscription.⁸

4. Where the competent authorities consider it advisable to make the meaning of a sign or symbol more explicit or to limit the application of a sign to certain periods, this can be done by inscriptions on the sign as provided in Annex 1 to this Convention or on an additional panel. If regulatory signs are to be restricted to certain road-users or if certain road-users are to be exempt from the regulation, this is done through additional panels according to Annex 1, section H, paragraph 4 (panels H, 5^a; H, 5^b; and H, 6).

5. The inscriptions referred to in paragraphs 3 and 4 of this Article shall be in the national language or in one or more of the national languages, and also, if the Contracting Party concerned considers it advisable, in other languages, in particular official languages of the United Nations.

⁷ Additional sentence introduced in the Annex of the European Agreement (see point 6).

⁸ See also point 7 of the Annex of the European Agreement.

DANGER WARNING SIGNS

ARTICLE 9

1. Section A, subsection I of Annex 1 to this Convention indicates the models for danger warning signs; Section A, subsection II indicates the symbols to be placed on these signs and gives some instructions for their use. In conformity with Article 46, paragraph 2 of this Convention, each State shall notify the Secretary-General whether it has selected A^a or A^b as the model for danger warning signs.⁹

2. The number of danger warning signs shall not be increased unnecessarily, but such signs shall be sited to give warning of possible road hazards which are difficult for a driver proceeding with due caution to perceive in time.

3. Danger warning signs shall be placed at such distance from the danger point as will make them most effective both by day and by night, having regard to road and traffic conditions, including the normal speed of vehicles and the distance at which the sign is visible.

4. The distance between the sign and the beginning of a dangerous section of road may be shown in an additional panel H, 1 of Annex 1, section H to this Convention and placed in accordance with the provisions of that section; this information must be given when the distance between the sign and the beginning of the dangerous section of road cannot be judged by drivers and is not what they might normally expect.

5. Danger warning signs may be repeated, particularly on motorways and roads treated as motorways. Where they are repeated, the distance between the sign and the beginning of the dangerous section of road shall be shown in accordance with the provisions of paragraph 4 of this Article.

However, with respect to danger warning signs giving warning of swing bridges and level crossings, it shall be open to Contracting Parties to apply the following provisions:

A rectangular panel having its longer sides vertical and bearing three oblique red bars on a white or yellow ground may be placed below any danger warning sign bearing one of the symbols A, 5; A, 25; A, 26 or A, 27 described in Annex 1, section A, subsection II, paragraphs 5, 25, 26 and 27 to this Convention, provided that additional signs consisting of panels of the same shape bearing respectively one or two oblique red bars on a white or yellow ground are set up at about one third and two thirds of the distance between the sign and the railway line. These signs may be repeated on the opposite side of the carriageway. The panels mentioned in this paragraph are further depicted in section A, subsection II, paragraph 29 of Annex 1 to this Convention.

6. If a danger warning sign is used to give warning of a danger on a section of road of some length (e.g. a series of dangerous bends or a section of carriageway in bad condition) and if it is considered desirable to show the length of that section, this shall be done on an additional panel H, 2 of Annex 1, section H to this Convention, placed in accordance with the provisions of that section.

REGULATORY SIGNS

ARTICLE 10

Priority signs

1. The signs for notifying or informing road-users of the special rules of priority at intersections are signs B, 1; B, 2; B, 3 and B, 4. The signs for informing road-users of a rule of

⁹ See also point 8 of the Annex of the European Agreement.

priority on narrow sections of road are signs B, 5 and B, 6. These signs are described in Annex 1, section B to this Convention.

2. Sign B, 1 "GIVE WAY", shall be used to notify drivers that, at the intersection where the sign is placed, they must give way to vehicles on the road they are approaching.

3. Sign B, 2, "STOP", shall be used to notify drivers that, at the intersection where the sign is placed, they shall stop before entering the intersection and give way to vehicles on the road they are approaching. In conformity with Article 46, paragraph 2, of this Convention, each State shall notify the Secretary-General whether it has selected B, 2^a or B, 2^b as the model for the "STOP" sign.¹⁰

4. Sign B, 1 or B, 2 may be placed elsewhere than at an intersection if the competent authorities consider it necessary.

5. Signs B, 1 and B, 2 shall be placed at the intersection, if possible level with the point at which vehicles must stop or beyond which they must not pass when giving way.

6. To give advance warning of sign B, 1 the same sign supplemented by an additional panel H, 1, described in Annex 1, section H to the Convention, shall be used. To give advance warning of sign B, 2, sign B, 1, supplemented by a rectangular panel bearing the "STOP" symbol and a figure indicating the distance to the sign B, 2 shall be used.¹¹

7. Sign B, 3, "PRIORITY ROAD", shall be used to notify users of a road that, at intersections of that road with other roads, the drivers of vehicles moving along or coming from such other roads are required to give way to vehicles moving along that road. This sign may be set up at the beginning of the road and repeated after each intersection; it may also be set up before or at the intersection. Where sign B, 3 has been set up on a road, sign B, 4, "END OF PRIORITY", shall be placed at the approach to the point where the road ceases to have priority over other roads. Sign B, 4 may be repeated one or more times in advance of the point where the priority ends; the sign or signs set up in advance of that point shall then bear an additional panel H, 1 of Annex 1, section H.

8. If warning of an intersection is given on a road by a danger warning sign bearing one of the A, 19 symbols, or if at the intersection the road is a priority road and has been marked as such by signs B, 3 as provided in paragraph 7 of this Article, a sign B, 1 or B, 2 shall be placed at the intersection on all the other roads; however, the placing of signs B, 1 or B, 2 shall not be mandatory on roads such as paths or earth-tracks where drivers are required to give way at the intersection even in the absence of such signs.

A sign B, 2 shall be set up only if the competent authorities consider it advisable to require drivers to stop, in particular because of the poor visibility, for drivers, of the sections of the road, on either side of the intersection, which they are approaching.

ARTICLE 11

Prohibitory or restrictive signs

Section C of Annex 1 to this Convention describes the prohibitory and restrictive signs and gives their meaning. It also describes the signs notifying the end of these prohibitions and restrictions or of any one of them.

¹⁰ See also point 9 of the Annex of the European Agreement.

¹¹ See also point 9 of the Annex of the European Agreement.

ARTICLE 12

Mandatory signs

Section D of Annex 1 to this Convention describes the mandatory signs and gives their meaning.

ARTICLE 13

Provisions applying generally to the signs described in Annex 1, sections C and D to this Convention

1. Prohibitory, restrictive and mandatory signs shall be placed in the immediate vicinity of the point where the obligation, restriction or prohibition begins and may be repeated if the competent authorities consider it necessary. Nevertheless, if the competent authorities consider it advisable for reasons of visibility or in order to give users advance warning, these signs may be placed at a suitable distance in advance of the point where the obligation, restriction or prohibition applies.

An additional panel H, 1 of Annex 1, section H shall be placed under signs set up in advance of the point where the obligation, restriction or prohibition applies.

2. Regulatory signs placed level with or shortly after a sign indicating the beginning of a built-up area shall mean that the rule applies throughout the built-up area, unless a different rule is notified by other signs on certain sections of the road in the built-up area.

3. Prohibitory and restrictive signs shall apply as from the place they are displayed until the point where a contrary sign is displayed, otherwise until the next intersection. If the prohibition or restriction should continue to be applied after the intersection the sign shall be repeated in accordance with provisions in domestic legislation.

4. Where a regulatory sign applies to all roads in a zone (zonal validity), it shall be displayed in the way described in Annex 1, section E, subsection II, paragraph 8 (a) to this Convention.

5. The exit from the zones referred to in paragraph 4 above shall be indicated in the way described in Annex 1, of section E, subsection II, paragraph 8 (b) of this Convention.

ARTICLE 13 bis

Special regulation signs

1. Section E of Annex 1 to this Convention describes the special regulation signs and gives their meaning.

2. Signs E, 7^a; E, 7^b; E, 7^c or E, 7^d and E, 8^a; E, 8^b; E, 8^c or E, 8^d shall notify road-users that the general regulations governing traffic in built-up areas in the territory of the State apply from signs E, 7^a; E, 7^b; E, 7^c; or E, 7^d to signs E, 8^a; E, 8^b; E, 8^c; or E, 8^d except in so far as different regulations may be notified by other signs on certain sections of road in the built-up area. However, sign B, 4 shall always be placed on a priority road marked with sign B, 3 if that road ceases to have priority where it passes through the built-up area. The provisions of Article 14, paragraphs 2, 3 and 4 apply to these signs.¹²

2 bis. Sign E, 11^a shall be used for tunnels of 1,000 m or more and in cases provided for by domestic legislation. For tunnels of 1,000 m or more, the length shall be included either in the lower part of the sign, or on an additional panel H, 2, as described in Annex 1, section H. The name of the tunnel may be indicated according to Article 8, paragraph 3 of this Convention.

¹² See also point 9 bis of the Annex of the European Agreement.

3. Signs E, 12^a; E, 12^b or E, 12^c shall be placed at pedestrian crossings when the competent authorities consider it advisable.
4. The special regulations signs shall be set up, with due regard to the requirements of Article 6, paragraph 1, only where the competent authorities consider it essential. They may be repeated; an additional panel placed below the sign may show the distance between the sign and the point which it indicates; this distance may also be inscribed on the lower part of the sign itself.

INFORMATIVE SIGNS

ARTICLE 14

1. Sections F and G of Annex 1 to this Convention describe the signs which convey useful information to road-users, or give examples of such signs, and also give some instructions for their use.
2. The inscription of words on informative signs (ii) of Article 5, paragraph 1 (c), in countries not using the Latin alphabet shall be both in the national language and in the form of a transliteration into the Latin alphabet reproducing as closely as possible the pronunciation in the national language.
3. In countries not using the Latin alphabet, the words in Latin characters may be entered either on the same sign as the words in the national language or on a repeat sign.
4. A sign shall not bear inscriptions in more than two languages.

ARTICLE 15

Advance direction signs

Advance direction signs shall be placed at such distance from the intersection as will make them most effective both by day and by night, having regard to road and traffic conditions, including the normal speed of vehicles and the distance at which the sign is visible; this distance need not exceed about 50 meters (55 yards) in built-up areas but shall be not less than 500 meters (550 yards) on motorways and other roads carrying fast traffic. The signs may be repeated. An additional panel placed below the sign may show the distance between the sign and the intersection; this distance may also be shown on the lower part of the sign itself.

ARTICLE 16

Direction signs

1. One direction sign may bear the names of several places; the names shall then appear one below the other on the sign. The letters used for one place name may be larger than those used for the others only if the place in question is the largest of them.
2. When distances are shown, the figures expressing them shall be inscribed at the same height as the place name. On direction signs which are arrow-shaped, these figures shall be placed between the place-name and the point of the arrow; on rectangular-shaped signs they shall be placed after the place-name.

ARTICLE 17

Road identification signs

The signs used to identify roads either by their number, made up of figures, letters or a combination of figures and letters, or by their name, shall consist of that number or that name

framed in a rectangle or shield. However, Contracting Parties having a route classification system may replace the rectangle by a route classification symbol.

ARTICLE 18

Place identification signs

Place identification signs may be used to show the frontier between two countries or the boundary between two administrative divisions of the same country or the name of a river, mountain pass, beauty spot, etc. These signs shall differ conspicuously from the signs referred to in Article 13 bis, paragraph 2, of this Convention.¹³

ARTICLE 19

Confirmatory signs

Confirmatory signs are used to confirm the direction of a road where the competent authorities consider it necessary, e.g. at the exit from a large built-up area. They shall bear the name of one or more places, as provided in Article 16, paragraph 1, of this Convention. Where distances are shown, the figures expressing them shall be placed after the name of the locality.

ARTICLE 20

[Deleted]

ARTICLE 21

Provisions applying generally to informative signs

1. The informative signs referred to in Articles 15 to 19 of this Convention shall be set up where the competent authorities consider it advisable. The other informative signs shall be set up, with due regard for the requirements of Article 6, paragraph 1, only where the competent authorities consider it essential; in particular, signs F, 2 to F, 7 shall be set up only on roads on which facilities for emergency repairs, refuelling, accommodation and refreshments are rare.

2. Informative signs may be repeated. An additional panel placed below the sign may show the distance between the sign and the point which it indicates; this distance may also be inscribed on the lower part of the sign itself.

[Title deleted]

ARTICLE 22

[Deleted]

¹³ See also point 10 of the Annex of the European Agreement.

Chapter III**TRAFFIC LIGHT SIGNALS****ARTICLE 23**Signals for vehicular traffic

1. Subject to the provisions of paragraph 12 of this Article, the only lights which may be used as light signals for regulating vehicle traffic, other than those intended solely for public transport vehicles, are the following, which shall have the meanings here assigned to them:

(a) Non-flashing lights:

- (i) A green light shall mean that traffic may proceed; however, a green light for controlling traffic at an intersection shall not authorize drivers to proceed if traffic is so congested in the direction in which they are about to proceed that if they entered the intersection they would probably not have cleared it by the next change of phase;
- (ii) A red light shall mean that traffic may not proceed; vehicles shall not pass the stop line or, if there is no stop line, shall not pass beyond the level of the signal or, if the signal is placed in the middle or on the opposite side of an intersection, shall not enter the intersection or move on to a pedestrian crossing at the intersection;
- (iii) An amber light, which shall appear alone or at the same time as the red light; when appearing alone it shall mean that no vehicle may pass the stop line or beyond the level of the signal unless it is so close to the stop line or signal when the light appears that it cannot safely be stopped before passing the stop line or beyond the level of the signal. Where the signal is placed in the middle or on the opposite side of an intersection the appearance of the amber light shall mean that no vehicle may enter the intersection or move on to a pedestrian crossing at the intersection unless it is so close to the crossing or the intersection when the light appears that it cannot be safely stopped before entering the intersection or moving on to the pedestrian crossing. When shown at the same time as the red light, it shall mean that the signal is about to change, but shall not affect the prohibition of passing indicated by the red light;

(b) Flashing lights:

- (i) A red flashing light, or two red lights flashing alternately, one light appearing when the other is extinguished, and mounted on the same support, at the same height, and facing the same direction shall mean that vehicles shall not pass the stop line or, if there is no stop line, shall not pass beyond the level of the signal; these lights may be used only at level-crossings, at approaches to swing bridges or ferry-boat landing stages, and to indicate that traffic may not proceed because of fire-fighting vehicles entering the road or of the approach of an aircraft which will cross the road at a lower altitude;
- (ii) A single amber flashing light or two amber lights flashing alternately shall mean that drivers may proceed but shall do so with particular care.

2. The signals of the three-colour system shall consist of three non-flashing lights, which shall be red, amber and green respectively; the green light shall appear only when the red and amber lights are extinguished.

3. The signals of the two-colour system shall consist of a non-flashing red light and a non-flashing green light. The red light and the green light shall not appear at the same time. Signals of the two-colour system shall be used only in temporary installation, subject to the period allowed under Article 3, paragraph 3, of this Convention for the replacement of existing installations.

3. bis (a) The provisions of Article 6, paragraphs 1, 2 and 3, of the Convention which relate to road signs shall apply to traffic light signals other than those used at level-crossings.

(b) Traffic light signals at intersections shall be placed before the intersection or in the middle of and above it; they may be repeated at the far side of the intersection and/or at the driver's eye level.

(c) In addition, it is recommended that domestic legislation should provide that traffic light signals:

- (i) Shall be so placed as not to impede vehicles moving in traffic on the carriageway and, in the case of signals set up on verges, as to impede pedestrians as little as possible;
- (ii) Shall be easily visible from a distance and readily understandable as they are approached; and
- (iii) Shall be standardized in the territory of each Contracting Party for the various categories of roads.

4. The lights of the three-colour and two-colour systems referred to in paragraphs 2 and 3 of this Article shall be arranged vertically or horizontally.

5. Where the lights are arranged vertically, the red light shall be placed uppermost; where the lights are arranged horizontally, the red light shall be placed on the side opposite to that appropriate to the direction of traffic.

6. In the three-colour system, the amber light shall be placed in the middle.

7. All the lights in the signals of the three-colour and two-colour systems referred to in paragraphs 2 and 3 of this Article shall be circular. The red flashing lights referred to in paragraph 1 of this Article shall likewise be circular.

8. A flashing amber light may be installed alone; such a light may also be used in place of a three-colour system at times when traffic is light.

9. In a three-colour system, the red, amber and green lights may be replaced by arrows of the same colour on a black background. When lighted up, these arrows have the same significance as the lights, but the prohibition or authorization is restricted to the direction or directions indicated by the arrow or arrows. Arrows signifying that traffic may or may not proceed straight ahead shall point upwards. Black arrows on a red, amber or green background may be used. These arrows have the same significance as the above-mentioned arrows.

10. Where a signal of a three-colour system includes one or more additional green lights showing one or more arrows, the lighting of such additional arrow or arrows shall, no matter what phase the three-colour system may be in at the time, mean that traffic may proceed in the direction or directions indicated by the arrow or arrows; it shall also mean that, when vehicles are in a lane reserved for traffic in the direction indicated by the arrow or the direction such traffic is required to take, their drivers must proceed in the direction indicated if by stopping they would obstruct the movement of vehicles behind them in the same lane, provided always that vehicles in the traffic stream they are joining must be allowed to pass and that pedestrians must not be endangered.

These additional green lights should preferably be placed at the same level as the normal green light.

11. (a) Where green or red lights are placed above traffic lanes shown by longitudinal markings on a carriageway having more than two lanes, the red light shall mean that traffic may not proceed along the lane over which it is placed and the green light shall mean that traffic may so proceed. The red light thus placed shall be in the form of two inclined crossed bars and the green light in the form of an arrow pointing downwards.

(b) When the competent authorities judge it necessary to introduce an "intermediate" or "transition" signal for the light signals, it should be in the form of an amber or white arrow pointing diagonally downwards to the left or to the right, or two such arrows, one pointing in each direction; these arrows may be flashing. These amber or white arrows mean that the lane is about to be closed to traffic and that the road-users on that lane must move over to the lane indicated by the arrow.

¹⁴ See footnote

12. Domestic legislation may provide for the installation at certain level-crossings of a slow-flashing lunar white light meaning that traffic may proceed.

13. In cases where traffic light signals apply to cyclists only, this restriction may be clarified, if to do so is necessary in order to avoid confusion, by including the silhouette of a cycle in the signal itself or by using a signal of small size supplemented by a rectangular plate showing a cycle.

ARTICLE 24

Signals for pedestrians only

1. The only lights which may be used as light signals for pedestrians only are the following, which shall have the meanings here assigned to them:

(a) Non-flashing lights:

- (i) A green light shall mean that pedestrians may cross;
- (ii) An amber light shall mean that pedestrians may not cross, but that those already on the carriageway may continue to the other side;¹⁵
- (iii) A red light shall mean that pedestrians may not enter the carriageway;

(b) Flashing lights: a flashing green light shall mean that the period during which pedestrians may cross the carriageway is about to end and the red light is about to appear.

2. Light signals for pedestrians shall preferably be of the two-colour system, comprising two lights, red and green respectively; however, they may be of the three-colour system, comprising three lights, red, amber and green respectively. Two lights shall never be shown simultaneously.¹⁶

3. The lights shall be arranged vertically, with the red light always at the top and the green light always at the bottom. The red light shall preferably be in the form of a standing pedestrian or of standing pedestrians and the green light in the form of a walking pedestrian or of walking pedestrians.¹⁷

¹⁴ Additional paragraph introduced in the Annex of the European Agreement (see point 11).

¹⁵ See also point 12 of the Annex of the European Agreement

¹⁶ See also point 12 of the Annex of the European Agreement

¹⁷ See also point 12 of the Annex of the European Agreement

4. Light signals for pedestrians shall be so designed and arranged as to exclude any possibility of their being mistaken by drivers for light signals for vehicular traffic.
5. Light signals for pedestrians may be supplemented by audible or tactile signals at pedestrian crossings to facilitate crossings of the carriageway by blind pedestrians.

Chapter IV

ROAD MARKINGS

ARTICLE 25

Carriageway markings (road markings) shall be used, when the competent authority considers it necessary, to regulate traffic or to warn or guide road-users. They may be used either alone or in conjunction with other signs or signals to emphasize or clarify their meaning.

ARTICLE 26

1. A longitudinal marking consisting of a continuous line on the carriageway shall mean that vehicles are not permitted to cross or straddle that line and, when the line separates the two directions of traffic, that vehicles are not permitted to travel on that side of the line which, for the driver, is opposite to the edge of the carriageway appropriate to the direction of traffic. A longitudinal marking consisting of two continuous lines shall have the same meaning.
2. (a) A longitudinal marking consisting of a broken line on the carriageway shall not have a prohibitory meaning, but shall be used either:
 - (i) To demarcate lanes for the purpose of guiding traffic; or
 - (ii) To give warning of the approach to a continuous line and the prohibition that line conveys, or of the approach to another section of road presenting a particular danger.

(b) The ratio between the length of the gaps between the strokes and the length of the strokes shall be substantially smaller where broken lines are used for the purposes referred to in subparagraph (a) (ii) of this paragraph than where they are used for the purpose referred to in subparagraph (a) (i) thereto.

¹⁸ See footnote

(c) Double broken lines may be used to delineate a lane or lanes in which the direction of the traffic flow may be reversed in conformity with Article 23, paragraph 11, of this Convention.

3. Where a longitudinal marking consists of a continuous line adjacent to a broken line on the carriageway, drivers shall take account only of the line that appears on their side. This provision shall not prevent drivers who have overtaken in the manner permitted from resuming their normal position on the carriageway.
4. For the purposes of this article, longitudinal lines used to mark the edges of the carriageway in order to make them more visible, longitudinal lines connected to transverse lines used to demarcate parking spaces on the carriageway, and longitudinal lines showing a prohibition or restrictions on standing or parking shall not be regarded as longitudinal markings.¹⁹

¹⁸ Additional paragraph introduced in the Annex of the Protocol on Road Markings (see point 3).

¹⁹ See also point 3 of the Annex of the Protocol on Road Markings.

ARTICLE 26 bis

1. The marking of lanes reserved for certain categories of vehicles, including cycle lanes, shall be by means of lines which should be clearly distinguished from other continuous or broken lines on the carriageway, notably by being wider and with less space between strokes.
2. When a lane is reserved for regular public transport service vehicles the worded road marking shall be the word "BUS" or the letter "A". The sign indicating such a line shall be of the square type described in annex 1, section E, or of the round type described in annex 1, section D, of the present Convention, showing the white symbol of a bus on a blue ground. Diagrams 28^a and 28^b shown in annex 2 to this Convention are examples of markings for a lane reserved for regular public transport service vehicles.
3. Domestic legislation shall specify under what conditions other vehicles may use or go across the lane referred to in paragraph 1.

ARTICLE 27

- 1.²⁰ A transverse marking consisting of a continuous line across one or more traffic lanes shall mark the line behind which drivers are required by the sign B, 2, "STOP", referred to in Article 10, paragraph 3, of this Convention, to stop.
Such a marking may also be used to show the line behind which drivers may be required to stop by a light signal, or by a signal given by an authorized official directing traffic, or before a level-crossing. The word "STOP" may be marked on the carriageway in advance of the markings accompanying sign B, 2.
2. Unless this is technically impossible, the transverse marking described in paragraph 1 of this Article shall be placed on the carriageway wherever a sign B, 2, is set up.
- 3.²¹ A transverse marking consisting of a broken line across one or more traffic lanes shall show the line which vehicles may not normally pass when giving way in compliance with the sign B, 1 "GIVE WAY", referred to in Article 10, paragraph 2, of this Convention.
In advance of such a marking, a triangle with broad sides, having one side parallel to the marking and the opposite vertex pointing towards approaching vehicles, may be marked on the carriageway to symbolize sign B, 1.
4. To mark pedestrian crossings, relatively broad stripes, parallel to the axis of the carriageway, should preferably be used.
- 5.²² To mark cyclist crossings, either transverse lines, or other markings which cannot be confused with those of pedestrian crossings, shall be used.

ARTICLE 28

1. Other markings on the carriageway, such as arrows, parallel or oblique stripes, or inscriptions, may be used to repeat the instructions given by signs or to give road-users information which cannot be suitably conveyed by signs. Such markings shall be used, in particular, to show the boundaries of parking zones or strips, to mark bus or trolleybus stops where parking is prohibited, and for pre-selection before intersections. However, if there is an arrow on the carriageway where it is divided into traffic lanes by means of longitudinal markings, drivers shall follow the direction or one of the directions indicated in the lane along which they are travelling.

²⁰ See also point 4 of the Annex of the Protocol on Road Markings.

²¹ See also point 4 of the Annex of the Protocol on Road Markings.

²² See also point 4 of the Annex of the Protocol on Road Markings.

2. Subject to the provisions of Article 27, paragraph 4 of this Convention which relate to pedestrian crossings, the marking of part of the carriageway or of an area raised slightly above the level of the carriageway by parallel oblique stripes framed by a continuous line, or by broken lines, shall, in the case of areas framed by a continuous line, mean that vehicles must not enter that area, and in the case of areas framed by broken lines, that vehicles shall not enter that area unless it can be seen that it is safe to do so or in order to turn into a joining road on the opposite side of the carriageway.

3. A zigzag line at the side of the carriageway shall mean that parking on that side of the carriageway is prohibited as far as the line extends. Such line possibly together with the word "BUS" or with the letter "A" may be used to indicate a bus or trolleybus stop.

²³ See footnote

ARTICLE 29

1. The road markings mentioned in Articles 26 and 28 of this Convention may be painted on the carriageway or applied in any other way provided that it is equally effective.

2.²⁴ If road markings are painted, they shall be yellow or white; however, blue may be used for markings showing places where parking is permitted but subject to some conditions or restrictions (limit of duration, payment, category of user, etc.).

When both yellow and white are used in the territory of a Contracting Party, markings of the same class shall be of the same colour. For the purposes of this paragraph, the term "white" shall include shades of silver or light grey.

²⁵ See footnote

3. In tracing out the inscriptions, symbols and arrows of road markings, account shall be taken of the need to elongate them considerably in the direction of movement of traffic, because of the very narrow angle at which they are seen by drivers.

4. Road markings intended for moving vehicles shall be easily recognized in good time by drivers. They must be visible during the day and at night. It is recommended that such markings, especially in areas where lighting is insufficient, be retroreflective.

ARTICLE 29 bis

1. When permanent road markings are to be modified for a specific period, in particular because of road works or diversions, temporary markings shall be applied in colours different from the colours used for permanent markings.

2. Temporary markings shall take precedence over permanent markings and road users are required to conform to them. When the simultaneous presence of permanent and temporary road markings could be a source of confusion, the permanent markings shall be covered over or removed.

3. Temporary markings shall preferably be retroreflective and may be supplemented by beacons, cats eyes or reflectors with a view to improving traffic guidance.

ARTICLE 30

Annex 2 to this Convention is a set of recommendations relating to the layout and design of road markings.

²³ Additional paragraphs introduced in the Annex of the Protocol on Road Markings (see point 5)

²⁴ See also point 6 of the Annex of the Protocol on Road Markings.

²⁵ Additional paragraph inserted in the Annex of the Protocol on Road Markings (see point 6).

Chapter V**MISCELLANEOUS****ARTICLE 31**Signs for road works

1. The limits of road works on the carriageway shall be clearly shown.
- 2.²⁶ Where the extent of the road works and the volume of traffic justify it, the limits of the works shall be marked by setting up continuous or discontinuous barriers painted with alternate red and white, red and yellow, black and white, or black and yellow stripes, and in addition, at night, if the barriers are not reflectorized, by lights and reflecting devices. Reflecting devices and fixed lights used for this purpose shall be red or dark yellow and flashing lights shall be dark yellow. However:
 - (a) Lights and devices visible only to traffic moving in one direction and marking the limits of road works on the opposite side of the road from that traffic may be white;
 - (b) Lights and devices marking the limits of road works separating the two directions of traffic may be white or light yellow.

ARTICLE 32Marking by lights or reflecting devices

Each Contracting Party shall adopt for the whole of its territory the same colour or the same system of colours for the lights or reflecting devices used to mark the edge of the carriageway.²⁷

LEVEL-CROSSINGS**ARTICLE 33**

1. (a)²⁸ Where a signaling system is installed at a level-crossing to give warning of the approach of trains or of the imminent closing of the gates (barriers) or half-gates (half-barriers), it shall consist of a red flashing light or of red lights flashing alternately, as specified in Article 23, paragraph 1(b), of this Convention. However:
 - (i) Flashing red lights may be supplemented or replaced by light signals of the three-colour red-amber-green system described in Article 23, paragraph 2, of this Convention, or by such a signal without the green light, if other three-colour light signals are installed on the road near the level-crossing or if the crossing is equipped with gates;
 - (ii) On earth-tracks (dirt roads) where traffic is very light and on footpaths, only a sound signal need be used.
- (b) The light signals may be supplemented by a sound signal in all cases.
2. The light signals shall be installed on the edge of the carriageway appropriate to the direction of traffic; whenever conditions such as the visibility of the signals or the density of traffic

²⁶ See also point 13 of the Annex of the European Agreement.

²⁷ See also point 14 of the Annex of the European Agreement.

²⁸ See also point 15 of the Annex of the European Agreement.

so require, the lights shall be repeated on the other side of the road. However, if it is considered preferable because of local conditions, the lights may be repeated on an island in the middle of the carriageway, or placed above the carriageway.²⁹

3. In accordance with Article 10, paragraph 4, of this Convention, sign B, 2, "STOP", may be set up at a level-crossing which has neither gates, half-gates nor light signals giving warning of the approach of trains; at level-crossings where this sign is displayed, drivers shall stop at the stop line or, in the absence of such a line, level with the sign and not move off again until they have ascertained that no train is approaching.

ARTICLE 34

1. At level-crossings equipped with gates or staggered half-gates on either side of the railway line, the presence of such gates or half-gates across the road shall mean that no road-user may proceed beyond the nearest gate or half-gate; the movement of gates towards a position across the road and the movement of half-gates shall have the same meaning.

2. The showing of the red light or lights mentioned in Article 33, paragraph 1 subparagraph (a), of this Convention, or the operation of the sound signal mentioned in the said paragraph 1, shall likewise mean that no road-user may proceed beyond the stop line or, if there is no stop line, beyond the level of the signal. The showing of the amber light of the three colour system mentioned in Article 33, paragraph 1 (a) (i), shall mean that no road-user may proceed beyond the stop line or, if there is no stop line, beyond the level of the signal, unless the vehicle concerned is so close to the signal when the amber light appears that it cannot safely be stopped before passing the signal.

ARTICLE 35

1. The gates and half-gates of level-crossings shall be clearly marked in alternate stripes of red and white, red and yellow, black and white, or black and yellow. They may, however, be coloured white or yellow only, provided that a large red disc is displayed at the centre.³⁰

2. At all level-crossings which have neither gates nor half-gates there shall be placed, in the immediate vicinity of the railway line, sign A, 28 as described in Annex 1, section A. If there is a light signal giving warning of the approach of trains or sign B, 2, "STOP", sign A, 28 shall be placed on the same support as the light signal or sign B, 2. Placing of sign A, 28 is not mandatory at:

(a) An intersection between a road and a railway track at which rail traffic proceeds very slowly and road traffic is regulated by a railwayman making the necessary hand signals; or

(b) An intersection between a railway track and either an earth-track (dirt road) where traffic is very light, or a footpath.

3. *[Deleted]*

ARTICLE 36

1. Because of the special danger presented by level-crossings, the Contracting Parties undertake:

(a) To have one of the danger warning signs bearing one of the symbols A, 25; A, 26 or A, 27 placed in advance of all level-crossings; however, no sign needs to be set up

²⁹ See also point 15 of the Annex of the European Agreement.

³⁰ See also point 16 of the Annex of the European Agreement.

-
- (i) In special cases which may arise in built-up areas;
- (ii) On earth-tracks (dirt roads) and paths where power-driven vehicular traffic is exceptional;
- (b) To have all level-crossings equipped with gates or half-gates or with a signal giving warning of the approach of trains, unless road-users can see the railway line on both sides of the level-crossing for such a distance that, allowing for the maximum speed of the trains, the driver of a road vehicle approaching the railway line from either side has time to stop before proceeding on to the level-crossing if a train is in sight, and in addition that road-users who are already on the crossing when a train appears have time to reach the other side; however, it shall be open to the Contracting Parties to derogate from the provisions of this subparagraph at level-crossings where trains travel relatively slowly or power-driven vehicular traffic on the road is light;
- (c) To have every level-crossing having gates or half-gates operated from a position from which such gates or half-gates cannot be seen equipped with one of the systems for signalling the approach of trains referred to in Article 33, paragraph 1, of this Convention;
- (d) To have every level-crossing having gates or half-gates operated automatically by the approach of trains equipped with one of the systems for signaling the approach of trains referred to in Article 33, paragraph 1, of this Convention;
- (e) In order to make gates and half-gates more visible, to have them equipped with reflecting material or reflecting devices and, if need be, to illuminate them at night; in addition, on roads where there is heavy motor traffic at night, to equip the danger warning signs installed in advance of the level-crossing with reflecting material or reflecting devices and, if need be, to illuminate them at night;
- (f) Wherever possible, near level-crossings equipped with half-gates to have a longitudinal marking placed in the middle of the carriageway prohibiting vehicles which approach the level-crossing from encroaching on the half of the carriageway reserved for traffic in the opposite direction or even to install directional islands separating the two opposed streams of traffic.
2. The provisions of this Article shall not apply in the cases referred to in the last sentence of Article 35, paragraph 2, of this Convention.

Chapter VI

FINAL PROVISIONS

ARTICLE 37

1. This Convention shall be open at United Nations Headquarters, New York, until 31 December 1969 for signature by all States Members of the United Nations or of any of the specialized agencies or of the International Atomic Energy Agency or Parties to the Statute of the International Court of Justice, and by any other State invited by the General Assembly of the United Nations to become a Party to the Convention.
2. This Convention is subject to ratification. The instruments of ratification shall be deposited with the Secretary-General of the United Nations.
3. This Convention shall remain open for accession by any of the States referred to in paragraph 1 of this Article. The instruments of accession shall be deposited with the Secretary-General.

ARTICLE 38

1. Any State may, at the time of signing or ratifying this Convention, or of acceding thereto, or at any time thereafter, declare by notification addressed to the Secretary-General that the Convention shall become applicable to all or any of the territories for the international relations of which it is responsible. The Convention shall become applicable to the territory or territories named in the notification 30 days after the receipt of the notification by the Secretary-General or on the date of entry into force of the Convention for the State making the notification, whichever is the later.
2. Any State which makes a notification under paragraph 1 of this Article shall notify on behalf of the territories on whose behalf that notification was made the declarations provided for in Article 46, paragraph 2 of this Convention.
3. Any State which has made a declaration under paragraph 1 of this Article may at any time thereafter declare by notification addressed to the Secretary-General that the Convention shall cease to be applicable to the territory named in the notification and the Convention shall cease to be applicable to such territory one year from the date of receipt by the Secretary-General of the notification.

ARTICLE 39

1. This Convention shall enter into force 12 months after the date of deposit of the fifteenth instrument of ratification or accession.
2. For each State ratifying or acceding to this Convention after the deposit of the fifteenth instrument of ratification or accession, the Convention shall enter into force 12 months after the date of deposit by such State of its instrument of ratification or accession.

ARTICLE 40

Upon its entry into force, this Convention shall terminate and replace, in relations between the Contracting Parties, the Convention concerning the Unification of Road Signals, opened for signature at Geneva on 30 March 1931, or the Protocol on Road Signs and Signals, opened for signature at Geneva on 19 September 1949.

ARTICLE 41

1. After this Convention has been in force for one year, any Contracting Party may propose one or more amendments to the Convention. The text of any proposed amendment, accompanied by an explanatory memorandum, shall be transmitted to the Secretary-General, who shall communicate it to all Contracting Parties. The Contracting Parties shall have the opportunity of informing him within a period of 12 months following the date of its circulation whether they: (a) accept the amendment; or (b) reject the amendment; or (c) wish that a conference be convened to consider the amendment. The Secretary-General shall also transmit the text of the proposed amendment to all other States referred to in Article 37, paragraph 1 of this Convention.
2. (a) Any proposed amendment communicated in accordance with the preceding paragraph shall be deemed to be accepted if within the period of 12 months referred to in the preceding paragraph less than one-third of the Contracting Parties inform the Secretary-General that they either reject the amendment or wish that a conference be convened to consider it. The Secretary-General shall notify all Contracting Parties of each acceptance or rejection of any proposed amendment and of requests that a conference be convened. If the total number of such rejections and requests received during the specified period of 12 months is less than one-third of the total number of Contracting Parties, the Secretary-General shall notify all Contracting Parties that the amendment will enter into force six months after the expiry of the period of 12 months referred to in the preceding paragraph for all Contracting Parties except those which, during the

period specified, have rejected the amendment or requested the convening of a conference to consider it.

(b) Any Contracting Party which, during the said period of 12 months, has rejected a proposed amendment or requested the convening of a conference to consider it may at any time after the end of such period notify the Secretary-General that it accepts the amendment, and the Secretary-General shall communicate such notification to all the other Contracting Parties. The amendment shall enter into force, with respect to the Contracting Parties which have notified their acceptance, six months after receipt by the Secretary-General of their notification.

3. If a proposed amendment has not been accepted in accordance with paragraph 2 of this Article and if within the period of 12 months specified in paragraph 1 of this Article less than half of the total number of Contracting Parties inform the Secretary-General that they reject the proposed amendment and if at least one-third of the total number of Contracting Parties, but not less than 10, inform him that they accept it or wish a conference to be convened to consider it, the Secretary-General shall convene a conference for the purpose of considering the proposed amendment or any other proposal which may be submitted to him in accordance with paragraph 4 of this Article.

4. If a conference is convened in accordance with paragraph 3 of this Article, the Secretary-General shall invite to it all States referred to in Article 37, paragraph 1 of this Convention. He shall request all States invited to the conference to submit to him, at least six months before its opening date, any proposals which they may wish the conference to consider in addition to the proposed amendment and shall communicate such proposals, at least three months before the opening date of the conference, to all States invited to the conference.

5. (a) Any amendment to this Convention shall be deemed to be accepted if it has been adopted by a two-thirds majority of the States represented at the Conference, provided that such majority comprises at least two-thirds of the number of Contracting Parties represented at the conference. The Secretary-General shall notify all Contracting Parties of the adoption of the amendment, and the amendment shall enter into force 12 months after the date of his notification of all Contracting Parties except those which during that period have notified the Secretary-General that they reject the amendment.

(b) A Contracting Party which has rejected an amendment during the said period of 12 months may at any time notify the Secretary-General that it accepts the amendment, and the Secretary-General shall communicate such notification to all the other Contracting Parties. The amendment shall enter into force, with respect to the Contracting Party which has notified its acceptance, six months after receipt by the Secretary-General of the notification or at the end of the said period of 12 months, whichever is later.

6. If the proposed amendment is not deemed to be accepted pursuant to paragraph 2 of this Article and if the conditions prescribed by paragraph 3 of this Article for convening a conference are not fulfilled, the proposed amendment shall be deemed to be rejected.

ARTICLE 42

Any Contracting Party may denounce this Convention by written notification to the Secretary-General. The denunciation shall take effect one year after the date of receipt by the Secretary-General of such notification.

ARTICLE 43

This Convention shall cease to be in force if the number of Contracting Parties is less than five for any period of 12 consecutive months.

ARTICLE 44

Any dispute between two or more Contracting Parties which relates to the interpretation or application of this Convention and which the Parties are unable to settle by negotiation or other means of settlement may be referred, at the request of any of the Contracting Parties concerned, to the International Court of Justice for decision.

ARTICLE 45

Nothing in this Convention shall be construed as preventing a Contracting Party from taking such action, compatible with the provisions of the Charter of the United Nations and limited to the exigencies of the situation, as it considers necessary to its external or internal security.

ARTICLE 46

1. Any State may, at the time of signing this Convention or of depositing its instrument of ratification or accession, declare that it does not consider itself bound by Article 44 of this Convention. Other Contracting Parties shall not be bound by Article 44 with respect to any Contracting Party which has made such a declaration.

2. (a) At the time of depositing its instrument of ratification or accession, every State shall, by notification addressed to the Secretary-General, declare for the purposes of the application of this Convention:

- (i) Which of the models A^a and A^b it chooses as a danger warning sign (Art. 9, para. 1), and
- (ii) Which of the models B, 2^a and B, 2^b it chooses as a stop sign (Art. 10, para. 3).

Any State may, subsequently, at any time, by notification addressed to the Secretary-General alter its choice by replacing its declaration by another.

(b) At the time of depositing its instrument of ratification or accession, any State may, by notification addressed to the Secretary-General, declare that for the purposes of the application of this Convention it treats Mopeds as motor cycles (art. 1, (l)).

By notification addressed to the Secretary-General, any State may subsequently, at any time, withdraw its declaration.

3. The declarations provided for in paragraph 2 of this Article shall become effective six months after the date of receipt by the Secretary-General of notification of them or on the date on which the Convention enters into force for the State making the declaration, whichever is the later.

4. Reservations to this Convention and its annexes, other than the reservation provided for in paragraph 1 of this Article, shall be permitted on condition that they are formulated in writing and, if formulated before the deposit of the instrument of ratification or accession, are confirmed in that instrument. The Secretary-General shall communicate such reservations to all States referred to in Article 37, paragraph 1 of this Convention.

5. Any Contracting Party which has formulated a reservation or made a declaration under paragraphs 1 and 4 of this Article may withdraw it at any time by notification addressed to the Secretary-General.

6. A reservation made in accordance with paragraph 4 of this Article:

- (a) Modifies for the Contracting Party which made the reservation the provisions of the Convention to which the reservation relates, to the extent of the reservation;
- (b) Modifies those provisions to the same extent for the other Contracting Parties in their relations with the Contracting Party which entered the reservation.

ARTICLE 47

In addition to the declarations, notifications and communications provided for in Articles 41 and 46 of this Convention, the Secretary-General shall notify all the States referred to in Article 37, paragraph 1, of the following:

- (a) Signatures, ratifications and accessions under Article 37;
- (b) Declarations under Article 38;
- (c) The dates of entry into force of this Convention in accordance with Article 39;
- (d) The date of entry into force of amendments to this Convention in accordance with Article 41, paragraphs 2 and 5;
- (e) Denunciations under Article 42;
- (f) The termination of this Convention under Article 43.

ARTICLE 48

The original of this Convention, of which the Chinese, English, French, Russian and Spanish texts done in a single copy are equally authentic, shall be deposited with the Secretary-General of the United Nations, who shall send certified true copies thereof to all the States referred to in Article 37, paragraph 1, of this Convention.

IN WITNESS WHEREOF the undersigned Plenipotentiaries,* being duly authorized by their respective Governments, have signed this Convention.

DONE AT Vienna this eighth day of November, one thousand nine hundred and sixty-eight.

* See document E/CONF.56/17/Rev.1.

ANNEXES

Annex 1

ROAD SIGNS

Section A

DANGER WARNING SIGNS

I. Models

1. The "A" DANGER WARNING signs shall be of model A^a or model A^b both described here and reproduced in Annex 3, except signs A, 28 and A, 29 described in paragraphs 28 and 29 below respectively. Model A^a is an equilateral triangle having one side horizontal and the opposite vertex above it; the ground is white or yellow and the border red. Model A^b is a square with one diagonal vertical; the ground is yellow and the border, which is only a rim, is black. Unless the description specifies otherwise, the symbols displayed on these signs shall be black or dark blue.
2. The size of the normal sized sign of model A^a shall measure approximately 0.90 m; that of the small sized sign of model A^a shall measure not less than 0.60 m. The size of the normal sized sign of model A^b shall measure approximately 0.60 m; that of the small sign of model A^b shall measure not less than 0.40 m.
3. As regards the choice between models A^a and A^b, see Article 5, paragraph 2, and Article 9, paragraph 1, of this Convention.

II. Symbols and instructions for the use of signs

1. Dangerous bend or bends

Warning of a dangerous bend or succession of dangerous bends shall be given by one of the following symbols, whichever is appropriate:

- (a) A, 1^a: left bend
- (b) A, 1^b: right bend
- (c) A, 1^c: double bend, or succession of more than two bends, the first to the left
- (d) A, 1^d: double bend, or succession of more than two bends, the first to the right.

2. Dangerous descent³¹

(a) To give warning of a steep descent symbol A, 2^a shall be used with the sign of model A^a, or symbol A, 2^b with the sign of model A^b.

(b) The left-hand part of symbol A, 2^a shall occupy the left-hand corner of the sign panel and its base shall extend over the whole width of the panel. The figure in symbols A, 2^a and A, 2^b shows the gradient as a percentage; it may be replaced by a ratio (1:10). It shall, however, be open to Contracting Parties taking into account as far as possible the provisions of Article 5, paragraph 2 (b) of this Convention, to use, instead of symbol A, 2^a or A, 2^b, symbol A, 2^c if they have adopted the sign of model A^a and symbol A, 2^d if they have adopted the sign of model A^b.

³¹ See also point 17 of the Annex of the European Agreement.

3. Steep ascent³²

(a) To give warning of a steep ascent, symbol A, 3^a shall be used with the sign of model A^a, or symbol A, 3^b with the sign of model A^b.

(b) The right-hand part of symbol A, 3^a shall occupy the right-hand corner of the sign panel and its base shall extend over the whole width of the panel. The figure in symbols A, 3^a and A, 3^b shows the gradient as a percentage; it may be replaced by a ratio (1:10). It shall, however, be open to Contracting Parties which have chosen symbol A, 2^c as the symbol for a dangerous descent to use symbol A, 3^c instead of A, 3^a, and to Contracting Parties which have chosen symbol A, 2^d to use symbol A, 3^d instead of A, 3^b.

4. Carriageway narrows

Warning that the carriageway ahead is narrower shall be given by the symbol A, 4^a or by a symbol showing the outline of the road more clearly, such as A, 4^b.

5. Swing bridge

(a) Warning of a swing bridge shall be given by the symbol A, 5.

(b) A rectangular panel of model A, 29^a described in paragraph 29 below may be placed below the danger warning sign bearing symbol A, 5, provided that panels of model A, 29^b and A, 29^c described in that paragraph are set up at approximately one third and two thirds of the distance between the sign bearing symbol A, 5 and the swing bridge.

6. Road leads on to quay or river bank

Warning that the road is about to lead on to a quay or river bank shall be given by symbol A, 6.

7. Uneven road

(a) Warning of dips, hump bridges or ridges, or of sections where the carriageway is in bad condition shall be given by symbol A, 7^a.

(b) To give warning of a hump bridge or ridge, symbol A, 7^a may be replaced by symbol A, 7^b.

(c) To give warning of a dip, symbol A, 7^a may be replaced by symbol A, 7^c.

8. Dangerous shoulders

(a) Warning of a section of road where the shoulders are particularly dangerous shall be given by symbol A, 8.

(b) The symbol may be reversed.

9. Slippery road

Warning that the section of road ahead may be particularly slippery shall be given by symbol A, 9.

³² See also point 17 of the Annex of the European Agreement.

10. Loose gravel

Warning of a section of road on which gravel may be thrown up shall be given by symbol A, 10^a used with the sign of model A^a or by symbol A, 10^b with the sign of model A^b.

11. Falling rocks

(a) Warning of a section of road on which there is danger from falling rocks and the consequent presence of rocks on the carriageway shall be given by symbol A, 11^a used with the sign of model A^a or by symbol A, 11^b with the sign of model A^b.

(b) The right-hand part of the symbol shall occupy the right-hand corner of the sign panel in both cases.

(c) The symbol may be reversed.

12. Pedestrian crossing³³

(a) Warning of a pedestrian crossing indicated either by road markings, or by signs E, 12 shall be given by symbol A, 12 of which there are two models: A, 12^a and A, 12^b.

(b) The symbol may be reversed.

13. Children

(a) Warning of a section of road frequented by children, such as the exit from a school or playground shall be given by symbol A, 13.

(b) The symbol may be reversed.

14. Cyclists entering or crossing

(a) Warning of a point at which cyclists frequently enter or cross the road shall be given by symbol A, 14.

(b) The symbol may be reversed.

15. Cattle or other animals crossing

(a) Warning of a section of road on which there is a particular danger of animals crossing shall be given by a symbol representing the silhouette of the animal, domestic or wild, most frequently encountered, such as symbol A, 15^a for a domestic animal and symbol A, 15^b for a wild animal.

(b) The symbol may be reversed.

16. Road works

Warning that work is in progress on the section of the road ahead shall be given by symbol A, 16.

³³ See also point 17 of the Annex of the European Agreement.

17. Light signals

(a) If it is considered essential to give warning of a section of road on which traffic is regulated by three-colour light signals, because road users would not expect such a section, symbol A, 17 shall be used. There are three models of symbol A, 17: A, 17^a; A, 17^b; and A, 17^c, which correspond to the arrangements of lights in the three-colour system described in Article 23, paragraphs 4 to 6 of this Convention.

(b) This symbol shall be in the three colours of the lights of which it gives warning.

18. Intersection where the priority is prescribed by the general priority rule³⁴

(a) Warning of an intersection where the priority is that prescribed by the general priority rule in force in the country shall be given by symbol A, 18^a used with sign A^a or by symbol A, 18^b used with sign A^b.

(b) Symbols A, 18^a and A, 18^b may be replaced by symbols which show the nature of the intersection more clearly, such as A, 18^c; A, 18^d; A, 18^e; A, 18^f and A, 18^g.

19. Intersection with a road the users of which must give way

(a) Warning of an intersection with a road the users of which must give way shall be given by symbol A, 19^a.

(b) Symbol A, 19^a may be replaced by symbols which show the nature of the intersection more clearly, such as A, 19^b and A, 19^c.

(c) These symbols may be used on a road only if sign B, 1 or sign B, 2 is placed on the road or roads with which it forms the intersection of which warning is given, or if these roads are such (for example, paths or earth-tracks) that, under domestic legislation, drivers using them are required to give way at the intersection even in the absence of such signs. The use of these symbols on roads on which sign B, 3 is set up shall be confined to certain exceptional cases.

20. Intersection with a road to whose users drivers must give way³⁵

(a) If the "GIVE WAY" sign B, 1 is placed at the intersection, the symbol A, 20 shall be used at the approach.

(b) If the "STOP" sign B, 2 is placed at the intersection, the symbol used at the approach shall be A, 21^a or A, 21^b whichever corresponds to the model of sign B, 2 set up.

(c) However, instead of sign A^a with these symbols, sign B, 1 or sign B, 2 may be used in conformity with Article 10, paragraph 6, of this Convention.

21. Roundabout

Warning of a roundabout shall be given by symbol A, 22.

³⁴ See also point 17 of the Annex of the European Agreement.

³⁵ See also point 17 of the Annex of the European Agreement.

22. Intersection where traffic is regulated by a light signal³⁶

If traffic at the intersection is regulated by a light signal, a sign A^a or A^b, bearing symbol A, 17 described in paragraph 17 above may be set up to supplement or replace the signs described in paragraphs 18 to 21 above.

23. Two-way traffic

(a) Warning of a section of road temporarily or permanently carrying two-way traffic on the same carriageway when, on the previous section, traffic was carried on a one-way road or on a road comprising several one-way traffic carriageways, shall be given by the symbol A, 23.

(b) The sign bearing this symbol shall be repeated at the beginning of the section and along the section as frequently as may be necessary.

24. Traffic congestion

(a) Warning that there may be traffic congestion on the section of road ahead shall be given by symbol A, 24.

(b) The symbol may be reversed.

25. Level-crossings with gates

Warning of level-crossings with gates or staggered half-gates on either side of the railway line, shall be given by symbol A, 25.

26. Other level-crossings³⁷

Warning of other level-crossings shall be given by symbol A, 26^a or A, 26^b, or by symbol A, 27 as appropriate.

27. Intersection with a tramway line

To give warning of an intersection with a tramway line, unless such intersection is a level-crossing as defined in Article 1 of the Convention, symbol A, 27 may be used.

NOTE - If it is considered necessary to give warning of intersections between a road and a railway track at which rail traffic proceeds very slowly and road traffic is regulated by a railwayman accompanying the railway vehicles and making the necessary hand signals, sign A, 32 described in paragraph 32 below shall be used.

28. Signs to be placed in the immediate vicinity of level-crossings³⁸

(a) There are three models of sign A, 28 referred to in Article 35, paragraph 2 of this Convention: A, 28^a; A, 28^b and A, 28^c.

(b) Models A, 28^a and A, 28^b shall have a white or yellow ground and a red or black border; model A, 28^c shall have a white or yellow ground and a black border; the inscription on model A, 28^c shall be in black letters. Model A, 28^b shall be used only if the railway line comprises at least two tracks; with model A, 28^c the additional panel shall be affixed only if the line comprises at least two tracks, in which case it shall indicate the number of tracks.

³⁶ See also point 17 of the Annex of the European Agreement.

³⁷ See also point 17 of the Annex of the European Agreement.

³⁸ See also point 17 of the Annex of the European Agreement.

(c) The normal length of the arms of the cross shall be not less than 1.20 m. If sufficient space is not available, the sign may be placed with its points directed upwards and downwards.

29. Additional signs at approaches to level-crossings or swing bridges

(a) The panels mentioned in Article 9, paragraph 5 of this Convention are signs A, 29^a, A, 29^b and A, 29^c. The bars shall slope downwards towards the carriageway.

(b) The danger warning sign for the level-crossing or swing bridge may be placed above signs A, 29^b and A, 29^c in the same way as it shall be placed above sign A, 29^a.

30. Airfield

(a) Warning of a section of road likely to be flown over at low altitude by aircraft taking off from or landing on an airfield shall be given by symbol A, 30.

(b) The symbol may be reversed.

31. Cross-wind

(a) Warning of a section of road on which there is often a strong cross-wind shall be given by symbol A, 31.

(b) The symbol may be reversed.

32. Other dangers

(a) Warning of a section of road on which there is a danger other than those enumerated in paragraphs 1 to 31 above or in section B of this annex may be given by symbol A, 32.

(b) It shall, however, be open to Contracting Parties to adopt graphic symbols in conformity with the provisions of Article 3, paragraph 1 (a) (ii) of this Convention.

(c) Sign A, 32 may be used, in particular, to give warning of intersections with railway tracks at which rail traffic proceeds very slowly and road traffic is regulated by a railwayman accompanying the railway vehicles and making the necessary hand signals.

Section B

PRIORITY SIGNS

NOTE - At an intersection comprising a priority road in which there is a bend, an additional panel H, 8 bearing a diagram of the intersection which shows the outline of the priority road may be placed below danger signs giving warning of the intersection or below priority signs, whether they are set up at the intersection or not.

1. "GIVE WAY" sign³⁹

(a) The "GIVE WAY" sign shall be sign B, 1. It shall consist of an equilateral triangle having one side horizontal and the opposite vertex below it. The ground shall be white or yellow and the border red. The sign shall bear no symbol.

³⁹ See also point 18 of the Annex of the European Agreement.

(b) The side of the normal sized sign shall measure approximately 0.90 m; the side of the small sign shall measure not less than 0.60 m.

2. "STOP" sign⁴⁰

(a) The "STOP" sign shall be sign B, 2, of which there are two models:

- (i) Model B, 2a is octagonal with a red ground bearing the word "STOP" in white in English or in the language of the State concerned; the height of the word shall be not less than one third of the height of the panel;
- (ii) Model B, 2b is circular with a white or yellow ground and a red border; it bears within it sign B, 1 without any inscription, and near the top, in large letters, the word "STOP" in black or dark blue, in English or in the language of the State concerned.

(b) The height of the normal sized sign B, 2^a and the diameter of the normal sized sign B, 2^b shall be approximately 0.90 m; the same dimensions of the small signs shall be not less than 0.60 m.

(c) As regards the choice between models B, 2^a and B, 2^b, see Article 5, paragraph 2, and Article 10, paragraph 3, of this Convention.

3. "PRIORITY ROAD" sign

(a) The "PRIORITY ROAD" sign shall be sign B, 3. It shall consist of a square with one diagonal vertical. The rim of the sign shall be black; the sign shall have in its centre a yellow or orange square with a black rim; the space between the two squares shall be white.

(b) The side of the normal sized sign shall measure approximately 0.50 m; the side of the small sign shall measure not less than 0.35 m.

4. "END OF PRIORITY" sign

The "END OF PRIORITY" sign shall be sign B, 4. It shall consist of sign B, 3 above with the addition of a black or grey median band perpendicular to the lower left and upper right sides of the square, or of black or grey parallel lines forming such a band.

5. Sign indicating priority for oncoming traffic

(a) If, on a narrow section of road where passing is difficult or impossible, traffic is regulated and if, because drivers can see the whole length of the section clearly both at night and by day, such regulation is carried out by giving priority to traffic moving in one direction and not by installing traffic light signals, sign B, 5 "PRIORITY FOR ONCOMING TRAFFIC" shall be set up facing the traffic on the side which does not have priority. This sign shall mean that entry into the narrow section is prohibited so long as it is not possible to pass through that section without obliging oncoming vehicles to stop.

(b) This sign shall be round, with a white or yellow ground and a red border; the arrow indicating the direction having priority shall be black and that indicating the other direction red.

⁴⁰ See also point 18 of the Annex of the European Agreement.

6. Sign indicating priority over oncoming traffic

(a) To notify drivers that on a narrow section of road they have priority over oncoming vehicles the sign used shall be B, 6.

(b) This sign shall be rectangular with a blue ground; the arrow pointing upwards shall be white and the other arrow red.

(c) When sign B, 6 is used, a sign B, 5 shall be placed on the road, at the other end of the narrow section, for traffic moving in the opposite direction.

Section C

PROHIBITORY OR RESTRICTIVE SIGNS

I. General characteristics and symbols

1. Prohibitory and restrictive signs shall be circular; their diameter shall be not less than 0.60 m outside built-up areas and not less than 0.40 m or 0.20 m for signs prohibiting or restricting standing and parking in built-up areas.

2. Unless otherwise specified where the signs in question are described, prohibitory or restrictive signs shall have a white or yellow ground or blue ground for signs prohibiting or restricting standing and parking with a wide red border; the symbols and the inscriptions, if any, shall be black or dark blue and the oblique bars, if any, shall be red and shall slope downwards from left to right.

II. Descriptions

1. Prohibition and restriction of entry⁴¹

(a) Notification that entry is prohibited for all vehicles shall be given by sign C, 1, "NO ENTRY", of which there are two models: C, 1^a, and C, 1^b.

(b) Notification that all vehicular traffic is prohibited in both directions shall be given by sign C, 2, "CLOSED TO ALL VEHICLES IN BOTH DIRECTIONS".

(c) Notification that entry is prohibited for a certain category of vehicle or road-user only, shall be given by a sign bearing as a symbol the silhouette of the vehicles or road-users whose entry is prohibited. Sign C, 3^a; C, 3^b; C, 3^c; C, 3^d; C, 3^e; C, 3^f; C, 3^g; C, 3^h; C, 3ⁱ; C, 3^j; C, 3^k; and C, 3^l shall have the following meanings:

C, 3^a "NO ENTRY FOR ANY POWER DRIVEN VEHICLE EXCEPT TWO-WHEELED MOTOR CYCLES WITHOUT SIDE-CAR"

C, 3^b "NO ENTRY FOR MOTOR CYCLES"

C, 3^c "NO ENTRY FOR CYCLES"

C, 3^d "NO ENTRY FOR MOPEDS"

C, 3^e "NO ENTRY FOR GOODS VEHICLES"

⁴¹ See also point 19 of the Annex of the European Agreement.

The inscription of a tonnage figure, either in a light colour on the silhouette of the vehicle or, in accordance with Article 8, paragraph 4 of this Convention, on an additional panel placed below sign C, 3^e, shall mean that the prohibition applies only if the permissible maximum mass of the vehicle or combination of vehicles exceeds that figure.

C, 3^f "NO ENTRY FOR ANY POWER DRIVEN VEHICLE DRAWING A TRAILER OTHER THAN A SEMI-TRAILER OR A SINGLE AXLE TRAILER"

The inscription of a tonnage figure, either in a light colour on the silhouette of the trailer or, in accordance with Article 8, paragraph 4, of this Convention, on an additional panel placed below sign C, 3^f, shall mean that the prohibition applies only if the permissible maximum mass of the trailer exceeds that figure.

It shall be open to Contracting Parties, in cases where they see fit to do so, to replace, in the symbol, the silhouette of the rear end of a lorry by that of the rear end of a private car, and the trailer silhouette by that of a trailer which can be attached to a private car.

C, 3^g "NO ENTRY FOR ANY POWER-DRIVEN VEHICLE DRAWING A TRAILER"

The inscription of a tonnage figure, either in a light colour on the silhouette of the trailer or, in accordance with article 8, paragraph 4 of this Convention, on an additional panel placed below sign C, 3^g, shall mean that the prohibition applies only if the permissible maximum mass of the trailer exceeds that figure.

C, 3^h "NO ENTRY FOR VEHICLES CARRYING DANGEROUS GOODS FOR WHICH SPECIAL SIGN PLATING IS PRESCRIBED"

To indicate no entry for vehicles carrying certain types of dangerous goods, the sign C, 3^h may be used in conjunction, if necessary, with an additional panel. The information given on this additional panel specifies that this prohibition applies only to the carriage of dangerous goods as defined by domestic legislation.

C, 3ⁱ "NO ENTRY FOR PEDESTRIANS"

C, 3^j "NO ENTRY FOR ANIMAL-DRAWN VEHICLES"

C, 3^k "NO ENTRY FOR HANDCARTS"

C, 3^l "NO ENTRY FOR POWER DRIVEN AGRICULTURAL VEHICLES"

NOTE - It shall be open to Contracting Parties to omit from signs C, 3^a to C, 3^l the red oblique bar joining the upper left quadrant and the lower right quadrant or, provided that this does not make the symbol less easy to see and understand, not to interrupt the bar where it crosses the symbol.

(d) Notification that entry is prohibited for several categories of vehicle or road user, may be given either by displaying as many prohibitory signs as there are prohibited classes, or by a single prohibitory sign which shows the silhouettes of the various vehicles or road-users whose entry is prohibited. Signs C, 4^a "NO ENTRY FOR POWER DRIVEN VEHICLES"; and C, 4^b "NO ENTRY FOR POWER DRIVEN VEHICLES OR ANIMAL-DRAWN VEHICLES" are examples of such signs.

Signs showing more than two silhouettes may not be set up outside built-up areas, and signs showing more than three silhouettes may not be set up in built-up areas.

(e) Notification that entry is prohibited for vehicles whose mass or dimensions exceed certain limits shall be given by the signs:

- C, 5 "NO ENTRY FOR VEHICLES HAVING AN OVERALL WIDTH EXCEEDING ... METRES"
- C, 6 "NO ENTRY FOR VEHICLES HAVING AN OVERALL HEIGHT EXCEEDING ... METRES"
- C, 7 "NO ENTRY FOR VEHICLES EXCEEDING ... TONNES LADEN MASS"
- C, 8 "NO ENTRY FOR VEHICLES HAVING A MASS EXCEEDING ... TONNES ON ONE AXLE"
- C, 9 "NO ENTRY FOR VEHICLES OR COMBINATIONS OF VEHICLES EXCEEDING ... METRES IN LENGTH".

(f) Notification that vehicles shall not be driven closer together than the distance indicated on the sign shall be given by sign C, 10, "DRIVING OF VEHICLES LESS THAN ... METRES APART PROHIBITED".

2. Prohibition of turning

Notification that turning is prohibited (to the right or to the left according to the direction of the arrow) shall be given by sign C, 11^a "NO LEFT TURN" or sign C, 11^b "NO RIGHT TURN".

3. Prohibition of U-turns

(a) Notification that U-turns are prohibited shall be given by sign C, 12 "NO U-TURNS".

(b) The symbol may be reversed, if appropriate.

4. Prohibition of overtaking⁴²

(a) Notification that, in addition to the general rules on overtaking laid down by the regulations in force, the overtaking of power-driven vehicles other than two-wheeled mopeds and two-wheeled motor cycles without side-car travelling on a road is prohibited, shall be given by sign C, 13^a "OVERTAKING PROHIBITED".

There are two models of this sign: C, 13^{aa} and C, 13^{ab}.

(b) Notification that overtaking is prohibited only for goods vehicles having a permissible maximum mass exceeding 3.5 tons shall be given by sign C, 13^b "OVERTAKING BY GOODS VEHICLES PROHIBITED".

There are two models of this sign: C, 13^{ba} and C, 13^{bb}.

An inscription on an additional panel placed below the sign in accordance with Article 8, paragraph 4 of this Convention may change the permissible maximum mass above which the prohibitions applies.

⁴² See also point 19 of the Annex of the European Agreement.

5. Speed limit

(a) Notification of a speed limit shall be given by sign C, 14, "MAXIMUM SPEED LIMITED TO THE FIGURE INDICATED". The figure appearing on the sign shall indicate the maximum speed in the unit of measurement most commonly used to express the speed of vehicles in the country concerned. After or below the figure expressing the speed may be added, for instance, "Km" (Kilometres) or "m" (Miles).

(b) To indicate a speed limit applicable only to vehicles of a permissible maximum mass exceeding a given figure, an inscription comprising that figure shall be placed on an additional panel below the sign in accordance with Article 8, paragraph 4 of this Convention.

6. Prohibition of the use of audible warning devices

Notification that the use of audible warning devices is prohibited, except to avoid an accident, shall be given by sign C, 15 "USE OF AUDIBLE WARNING DEVICES PROHIBITED". This sign, if not placed at the beginning of a built-up area beside or shortly after the sign identifying the built-up area, shall be accompanied by an additional panel H, 2 described in section H of this annex, showing the distance over which the prohibition applies. It is recommended that this sign should not be placed at the beginning of built-up areas when the prohibition applies in all built-up areas and that it be provided that the sign identifying a built-up area placed at the beginning of that area shall notify road users that the traffic regulations applicable to built-up areas in that country apply from that point onwards.

7. Prohibition of passing without stopping

(a) Notification of the proximity of a Custom-house at which a stop is compulsory shall be given by sign C, 16, "PASSING WITHOUT STOPPING PROHIBITED". Notwithstanding Article 8 of this Convention, the symbol of this sign shall include the word "Customs", preferably in two languages; Contracting Parties using C, 16 signs shall endeavour to reach a regional agreement to the effect that this word shall appear in the same language on all the signs they set up.

(b) This sign may also be used to notify drivers that passing without stopping is prohibited for other reasons; in this case the word "Customs" shall be replaced by another very brief inscription indicating the reason for the stop.

8. End of prohibition or restriction

(a) The point at which all prohibitions notified by prohibitory signs for moving vehicles cease to apply shall be indicated by sign C, 17^a "END OF ALL LOCAL PROHIBITIONS IMPOSED ON MOVING VEHICLES". This sign shall be circular and have a white or yellow ground; it shall have no border or only a black rim, and shall bear a diagonal band, sloping downward from right to left, which may be black or dark grey or consist of black or grey parallel lines.

(b) The point at which a particular prohibition or restriction notified to moving vehicles by a prohibitory or restrictive sign ceases to apply shall be indicated by sign C, 17^b "END OF SPEED LIMIT" or sign C, 17^c "END OF PROHIBITION OF OVERTAKING", OR SIGN C, 17^d "END OF PROHIBITION OF OVERTAKING FOR GOODS VEHICLES". These signs shall be similar to sign C, 17^a, but shall show, in addition, in light grey the symbol of the prohibition or restriction which has ceased.

(c) Notwithstanding the provisions of Article 6, paragraph 1 of this Convention, the signs referred to in this paragraph 8 may be placed on the reverse side of the prohibitory or restrictive sign intended for traffic coming in the opposite direction.

9. Prohibition or restriction of standing and parking

- (a) (i) Places where parking is prohibited shall be indicated by sign C, 18, "PARKING PROHIBITED"; places where standing and parking are prohibited shall be indicated by sign C, 19, "STANDING AND PARKING PROHIBITED".
- (ii) Sign C, 18 may be replaced by a circular sign with a red border and a red transverse bar, bearing the letter or ideogram used in the State concerned to denote "Parking", in black on a white or yellow ground.⁴³
- (iii) The scope of the prohibition may be restricted by inscriptions on an additional plate below the sign specifying, as the case may be, The days of the week or month or the times of day during which the prohibition applies;
- The time in excess of which parking is prohibited by sign C, 18 or standing and parking is prohibited by sign C, 19;
- The exceptions granted for certain classes of road user.
- (iv) The time in excess of which parking or standing is prohibited may also be inscribed on the lower part of the red circle of the sign instead of appearing on an additional plate.
- (b) (i) Where parking is authorized on opposite sides of the road alternately, signs C, 20^a and C, 20^b, "ALTERNATE PARKING", shall be used instead of sign C, 18;
- (ii) The prohibition of parking shall apply to the sign C, 20^a side on odd number dates and to the sign C, 20^b side on even number dates; the time at which the side changes shall be prescribed by domestic legislation and need not necessarily be midnight. Domestic legislation may also prescribe an alternation other than a daily alternation for parking; the numerals I and II shall in that case be replaced on the signs by the period of alternation, e.g., 1-15 and 16-31 for an alternation on the first and sixteenth day of each month.
- (iii) Sign C, 18 may be used by States which do not adopt sign C, 19; C, 20^a and C, 20^b, supplemented by additional inscriptions, as provided in Article 8, paragraph 4 of this Convention.⁴⁴
- (c) (i) Except in special cases, the signs shall be so placed that their disc is perpendicular to the axis of the road, or at a slight angle to the plane perpendicular to that axis.
- (ii) All the prohibitions and restrictions of parking shall apply only on the side of the carriageway on which the signs are placed.

⁴³ See also point 19 of the Annex of the European Agreement.

⁴⁴ See also point 19 of the Annex of the European Agreement.

- (iii) Except as may be otherwise indicated:
On an additional panel H, 2 of section H of this annex and showing the distance over which the prohibition applies; or
- In conformity with subparagraph (c) (v) of this paragraph, the prohibitions shall apply from a point level with the sign to the next point of entry of a road.
- (iv) An additional panel H, 3^a or H, 4^a depicted in section H of this annex may be placed below the sign at the point where the prohibition begins. An additional panel H, 3^b or H, 4^b depicted in section H of this annex may be placed below signs repeating the prohibition. A further prohibition sign supplemented by an additional panel H, 3^c or H, 4^c depicted in section H of this annex may be placed at the point where the prohibition ceases to apply. Panels H, 3 shall be placed parallel to the axis of the road, and panels H, 4 perpendicular to that axis. The distances, if any, shown by panels H, 3 shall be those over which the prohibition applies in the direction of the arrow.
- (v)⁴⁵ If the prohibition ceases to apply before the next point of entry of a road, the sign bearing the additional end-of prohibition panel described in subparagraph (c) (iv) above shall be set up. However, where the prohibition applies only over a short distance, it shall be permissible to set up only one sign:
- Showing in the red circle the distance on which it applies, or
- Bearing an additional panel H, 3.
- (vi) Where parking-meters are installed, their presence shall signify that parking is subject to payment and is limited to the period for which the meter operates.
- (vii) *[Deleted]*

Section D

MANDATORY SIGNS

I. General characteristics and symbols

1. Mandatory signs shall be circular, except signs D, 10 described in subsection II, paragraph 10 of this section which shall be rectangular; their diameter shall be not less than 0.60 m outside built-up areas and not less than 0.40 m in built-up areas. However, signs having a diameter of not less than 0.30 m may be used in conjunction with traffic light signals or on bollards on traffic islands.

2. Unless provided otherwise, the signs shall be blue and the symbols shall be white or of a light colour, or, alternatively, the signs shall be white with a red rim and the symbols shall be black.⁴⁶

⁴⁵ See also point 19 of the Annex of the European Agreement.

⁴⁶ See also point 20 of the Annex of the European Agreement.

II. Descriptions

1. Direction to be followed⁴⁷

The direction in which vehicles are obliged to proceed, or the only directions in which they are permitted to proceed, shall be indicated by model D, 1^a of sign D, 1, "DIRECTION TO BE FOLLOWED" on which the arrow or arrows shall point in the appropriate direction or directions. However, instead of using sign D, 1^a, sign D, 1^b may be used notwithstanding the provisions of subsection I of this section. Sign D, 1^b shall to be black with a white rim and a white symbol.

2. Pass this side

Sign D, 2 "PASS THIS SIDE", placed, notwithstanding the provisions of Article 6, paragraph 1 of this Convention, on an island or before an obstacle on the carriageway, shall mean that vehicles must pass on the side of the island or obstacle indicated by the arrow.

3. Compulsory roundabout

3. Sign D, 3 'COMPULSORY ROUNDABOUT', shall notify drivers that they must follow the direction at the roundabout indicated by the arrows. If the roundabout is indicated by the sign D, 3 together with the sign B, 1 or B, 2, the driver in the roundabout has priority.

4. Compulsory cycle track

Sign D, 4 "COMPULSORY CYCLE TRACK" shall notify cyclists that the track at the entrance to which it is placed is reserved for them, and shall notify the drivers of other vehicles that they are not entitled to use that track. Cyclists shall be required to use the track if the track is running along a carriageway, footpath or track for riders on horseback and leading into the same direction. However, drivers of mopeds shall also be required, in the same conditions, to use the cycle track if domestic legislation so provides or if notification of this requirement is given by an additional panel bearing an inscription or the symbol of sign C, 3^d.

5. Compulsory footpath

Sign D, 5 "COMPULSORY FOOTPATH" shall notify pedestrians that the path at the entrance to which it is placed is reserved for them, and shall notify other road users that they are not entitled to use that path. Pedestrians shall be required to use the path if the path is running along a carriageway, cycle track or track for riders on horseback and leading into the same direction.

6. Compulsory track for riders on horseback

Sign D, 6 "COMPULSORY TRACK FOR RIDERS ON HORSEBACK" shall notify riders on horseback that the track at the entrance of which it is placed is reserved for them and shall notify other road users that they are not entitled to use that track. Riders on horseback shall be required to use the track if the track is running along a carriageway, cycle track or footpath and leading into the same direction.

7. Compulsory minimum speed

Sign D, 7 "COMPULSORY MINIMUM SPEED", shall mean that vehicles using the road at the entrance to which it is placed shall travel at not less than the speed specified, the figure

⁴⁷ See also point 21 of the Annex of the European Agreement.

shown on the sign shall express this speed in the unit of measurement most commonly used to express the speed of vehicles in the country concerned. After the figure specifying the speed may be added, for instance, "Km" (Kilometres) or "m" (Miles).

8. End of compulsory minimum speed

Sign D, 8 "END OF COMPULSORY MINIMUM SPEED", shall mean that the compulsory minimum speed imposed by sign D, 7 is no longer in effect. Sign D, 8 shall be identical to sign D, 7, except that it shall be crossed by an oblique red bar running from the upper right edge to the lower left edge.

9. Snow chains compulsory

Sign D, 9, "SNOW CHAINS COMPULSORY" shall mean that vehicles travelling on the road at the entrance to which it is placed shall have snow chains fitted to not less than two of their driving wheels.

10. Compulsory direction for vehicles carrying dangerous goods

Sign D, 10^a; D, 10^b and D, 10^c shall indicate the direction in which vehicles carrying dangerous goods shall proceed.

11. Remarks concerning the combination of signs D, 4; D, 5 and D, 6

(a) Notification that a path or track is reserved to two categories of road users and prohibited to other users shall be indicated by a mandatory sign bearing the two symbols for the categories of users entitled to use the path or track at the entrance to which it is placed.

(b) When the symbols are placed side by side on the sign and separated by a vertical line through the centre of the sign, each symbol shall be understood to mean that the relevant category must use the side of the path or track reserved for that category and shall notify other road users that they are not entitled to use that side. The two sides of the path or track shall be clearly separated, by physical means or road markings.

(c) When the symbols are placed one above the other, the sign shall notify the relevant categories of users that they may jointly use the path or track. The order in which the symbols are placed shall be optional. Where necessary the precautions to be taken by both categories of users shall be laid down in domestic legislation.

Sign D, 11^a and D, 11^b are examples of the combination of signs D, 4 and D, 5.

Section E

SPECIAL REGULATION SIGNS

I. General characteristics and symbols

Special regulation signs are usually square or rectangular with a blue ground and a light coloured symbol or inscription, or with a light coloured ground and a dark coloured symbol or inscription.

II. Descriptions

1. Signs indicating a regulation or danger warning applying to one or more traffic lanes

Signs such as those given below shall mean that a regulation or danger warning applies only to one or more lanes, defined by longitudinal lane markings, on a multi-lane carriageway for traffic moving in the same direction. They may also indicate lanes allocated to oncoming traffic. The sign relating to the regulation or danger warning shall be shown on each of the arrows concerned:

- (i) E, 1^a "COMPULSORY MINIMUM SPEED APPLYING TO DIFFERENT LANES".
- (ii) E, 1^b "COMPULSORY MINIMUM SPEED APPLYING TO ONE LANE". This sign may be used as way of creating a "slow lane".
- (iii) E, 1^c "SPEED LIMITS APPLYING TO DIFFERENT LANES". Borders of the circles shall be red and letters black.

2. Signs indicating lanes reserved for buses

Signs such as E, 2^a and E, 2^b are examples of signs showing the position of the lane reserved for buses in accordance with Article 26 bis, paragraph 2.

3. "ONE-WAY" sign

(a) Two different "ONE-WAY" signs may be set up where it is necessary to indicate a road or carriageway which is one-way:

- (i) Sign E, 3^a placed approximately perpendicular to the axis of the carriageway; its panel shall be square.
- (ii) Sign E, 3^b placed approximately parallel to the axis of the carriageway; its panel shall be an elongated rectangle the long side of which is horizontal. The words "one way" may be inscribed on the arrow of sign E, 3^b in the national language or one of the national languages of the country concerned.⁴⁸

(b) Signs E, 3^a and E, 3^b may be set up irrespective of whether prohibitory or mandatory signs are set up at the entrance to the road in question.

4. Preselection sign

Example of sign for preselection at intersections on roads with several lanes: E, 4.

5. Signs notifying an entry to or an exit from a motorway

(a) Sign E, 5^a, "MOTORWAY", shall be placed at the point where the special rules to be observed on a motorway begin to apply.

⁴⁹ See footnote

⁴⁸ See also point 22 of the Annex of the European Agreement.

⁴⁹ Additional sub-paragraph introduced in the Annex of the European Agreement (see point 22)

(b) Sign E, 5^b, "END OF MOTORWAY", shall be placed at the point where those rules cease to apply.

(c) Sign E, 5^b may also be used and repeated to give warning of the ending of a motorway; the distance between each sign set up for this purpose and the end of the motorway shall be inscribed on the lower part of the sign.

(d) These signs shall have blue or green ground.

6. Signs notifying an entry to or exit from a road on which the traffic rules are the same as on a motorway

(a) Sign E, 6^a, "ROAD FOR MOTOR VEHICLES", shall be placed at the point where special traffic rules begin to apply on roads other than motorways which are reserved for motor vehicle traffic and do not serve properties bordering on the road. An additional panel may be placed under sign E, 6^a to show that, by way of exception, the access of motor vehicles to properties bordering on the road is permitted.

⁵⁰ See footnote

(b) Sign E, 6^b, "END OF ROAD FOR MOTOR VEHICLES", may also be used and repeated to give warning of the ending of the road; the distance between each sign set up for this purpose and the end of the road shall be inscribed on the lower part of the sign.

(c) These signs shall have blue or green ground.

7. Signs indicating the beginning and the end of a built-up area⁵¹

(a) The sign to indicate the beginning of a built-up area shall bear the name of the built-up area or the symbol showing the silhouette of a built-up area or the two combined. Signs E, 7^a; E, 7^b; E, 7^c and E, 7^d are examples of signs showing the beginning of a built-up area.

(b) The sign showing the end of a built-up area shall be identical except that it shall be crossed by an oblique bar coloured red or consisting of parallel lines coloured red running from the upper right edge to the lower left edge. Signs E, 8^a; E, 8^b; E, 8^c and E, 8^d are examples of signs indicating the end of a built-up area.

Notwithstanding the provisions of Article 6, paragraph 1 of this Convention these signs may be placed on the reverse side of signs identifying a built-up area.

(c) The signs covered by this paragraph shall be used in conformity with the provisions of the Convention, Article 13 *bis*, paragraph 2.

8. Signs having zonal validity

(a) Beginning of a zone

(i) To indicate that a sign applies to all roads in a zone (zonal validity), the sign shall be displayed on a rectangular panel with a light-coloured ground. The word "ZONE" or its equivalent in the national language may be displayed above or below the sign on the panel. Specific details of the restrictions, prohibitions or obligations indicated by the sign may be given below the sign on the panel or on an additional panel.

⁵⁰ Additional sub-paragraph introduced in the Annex of the European Agreement (see point 22)

⁵¹ See also point 22 of the Annex of the European Agreement.

Signs applying to all roads in a zone (zonal validity) shall be set up at all roads giving access to the zone concerned. The zone preferably should only include roads which have similar characteristics.

- (ii) Signs E, 9^a; E, 9^b; E, 9^c and E, 9^d are examples of signs applying to all roads in a zone (zonal validity):

E, 9^a - Zone in which parking is prohibited;
 E, 9^b - Zone in which parking is prohibited at certain times;
 E, 9^c - Parking zone;
 E, 9^d - Maximum speed zone.

- (b) Exit from a zone

- (i) To indicate the exit from a zone in which a sign has zonal validity, the same sign displayed on a rectangular panel shall be set up as that placed at the entry to the zone but it shall be grey on a rectangular panel with a light coloured ground. A black or dark grey diagonal band or parallel grey or black lines forming such a band shall slope downwards across the sign from right to left.

Signs indicating the exit from a zone shall be set up on all roads which may be used to leave that zone.

- (ii) Signs E, 10^a; E, 10^c and E, 10^d are examples of signs indicating the exit from a zone in which a sign applies to all roads (zonal validity):

E, 10^a - End of zone in which parking is prohibited;
 E, 10^b - End of zone in which parking is prohibited at certain times;
 E, 10^c - End of parking zone;
 E, 10^d - End of maximum speed zone.

9. Signs notifying the entry to or exit from a tunnel where special rules apply

(a) Sign E, 11^a 'TUNNEL' indicates a section of road passing through a tunnel and on which special traffic rules apply. It is placed at the point from which these rules apply.

(b) In order to warn road users in advance, sign E, 11^a may be placed in addition at a suitable distance before the point where the special rules apply; such sign shall show, either in its lower part, or on an additional panel H, 1, as described in section H of this Annex, the distance between the point at which it is set up and the point from which these special rules apply.

(c) Sign E, 11^b 'END OF TUNNEL' may be placed at the point from which the special rules no longer apply.

10. "PEDESTRIAN CROSSING" sign⁵²

(a) Sign E, 12^a, "PEDESTRIAN CROSSING", is used to show pedestrians and drivers the position of a pedestrian crossing. The ground of the panel shall be blue or black, the triangle white or yellow and the symbol black or dark blue; the symbol displayed shall be symbol A, 12.

⁵² See also point 22 of the Annex of the European Agreement.

(b) However, the sign E, 12^b, having the shape of an irregular pentagon, a blue ground and a white symbol or the sign E, 12^c, having a dark ground and white symbol may also be used.

11. "HOSPITAL" sign

(a) This sign shall be used to notify drivers of vehicles that they should take the precautions required near medical establishments; in particular, that they should not make any unnecessary noise. There are two models of this sign: E, 13^a and E, 13^b.

(b) The red cross on sign E, 13^b may be replaced by one of the symbols referred to in section F, subsection II, paragraph 1.

12. "PARKING" sign

(a) Sign E, 14^a, "PARKING", which may be set up parallel to the axis of the road, shall indicate places where the parking of vehicles is authorized. The panel shall be square⁵³. It shall bear the letter or ideogram used in the State concerned to denote "Parking". The ground of this sign shall be blue.

(b) The direction in which the parking place lies or the categories of vehicle for which it is reserved may be shown on the sign itself or on an additional panel below the sign. Such inscriptions may also limit the period for which parking is permitted or indicate that public transport is accessible from the parking place by means of a "+" sign" followed by an indication of the type of transport, in word or symbol form.

Signs E, 14^b and E, 14^c are examples of the signs which may be used to indicate a car park more particularly intended for vehicles whose drivers wish to use a means of public transport.

13. Signs notifying a bus or tramway stop

E, 15 "BUS. STOP" and E, 16 "TRAMWAY STOP".

⁵⁴ See footnote

14. Signs indicating a stopping place in case of emergency or danger

Sign E, 18⁵⁵ "EMERGENCY STOPPING PLACE" indicates a place which shall only be used by drivers for stopping or parking in case of emergency or danger. If this stopping place is equipped with an emergency telephone and/or an extinguisher, the sign shall bear the symbols F, 14 and/or F, 15⁵⁶ either in its lower part or on a rectangular panel placed below the sign. This sign has two models, E, 18^a⁵⁷ and E, 18^b⁵⁸.

⁵³ See also point 22 of the Annex of the European Agreement.

⁵⁴ Additional paragraph introduced in the Annex of the European Agreement (see point 22).

⁵⁵ See corrigendum ECE/TRANS/WP.1/2003/3/Rev.4/Corr.1. The number previously attributed was E, 17

⁵⁶ See footnotes 63 and 64

⁵⁷ See corrigendum ECE/TRANS/WP.1/2003/3/Rev.4/Corr.1. The number previously attributed was E, 17^a

⁵⁸ See corrigendum ECE/TRANS/WP.1/2003/3/Rev.4/Corr.1. The number previously attributed was E, 17^b

Section F

INFORMATION, FACILITIES OR SERVICE SIGNS

I. General characteristics and symbols

1. "F" signs shall have a blue or green ground; they shall bear a white or yellow rectangle on which the symbol shall be displayed.

2. On the blue or green band at the bottom of the sign, the distance to the facility indicated, or to the entry to the road leading to it, may be inscribed in white; on the sign bearing symbol F, 5 the word "HOTEL" or "MOTEL" may be inscribed in the same way. The signs may also be set up at the entry to the road leading to the facility and may then bear a white directional arrow on the blue or green part at the bottom.

The symbol shall be black or dark blue, except symbols F, 1^a, F, 1^b, F, 1^c and F, 15, which shall be red. The symbol F, 14 may be red.

II. Descriptions

1. "FIRST-AID STATION" symbol⁵⁹

The symbols depicting first-aid stations in the States concerned shall be used. These symbols shall be red. Examples of these symbols are F, 1^a, F, 1^b and F, 1^c.

2. Miscellaneous symbols

F, 2 "BREAKDOWN SERVICE"

F, 3 "TELEPHONE"

F, 4 "FILLING STATION"

F, 5 "HOTEL or MOTEL"

F, 6 "RESTAURANT"

F, 7 "REFRESHMENTS OR CAFETERIA"

F, 8 "PICNIC SITE"

F, 9 "STARTING-POINT FOR WALKS"

F, 10 "CAMPING SITE"

F, 11 "CARAVAN SITE"

F, 12 "CAMPING AND CARAVAN SITE"

F, 13 "YOUTH HOSTEL"

F, 14⁶⁰ *See footnote*

F, 15⁶¹ *See footnote*

⁵⁹ See also point 23 of the Annex of the European Agreement.

⁶⁰ See also point 23 of the Annex of the European Agreement.

F, 16⁶² *See footnote*

F, 17⁶³ "EMERGENCY TELEPHONE"

F, 18⁶⁴ "EXTINGUISHER"

⁶⁵ *See footnote*

Section G

DIRECTION, POSITION OR INDICATION SIGNS

I. General characteristics and symbols

1. Informative signs are usually rectangular; however, direction signs may be in the shape of an elongated rectangle with the longer side horizontal, terminating in an arrowhead.
2. Informative signs shall bear either white or light-coloured symbols or inscriptions on a dark ground, or dark-coloured symbols or inscriptions on a white or light-coloured ground; the colour red may be used only exceptionally and must never predominate.
3. Advance direction signs or direction signs relating to motorways or roads treated as motorways shall bear white symbols or inscriptions on a blue or green ground. On such signs the symbols used on signs E, 5^a and E, 6^a may be reproduced on reduced scale.
4. Signs indicating temporary conditions such as road works, diversions or detours may have orange or yellow ground with black symbols and inscriptions.
5. On signs G, 1; G, 4; G, 5; G, 6 and G, 10 it is recommended to show place names in the language of the country, or subdivision thereof, where the localities referred to are situated.

II. Advance direction signs

1. General case

Examples of advance direction signs: G, 1^a; G, 1^b and G, 1^c.

2. Special cases

- (a) Examples of advance direction signs for "NO THROUGH ROAD": G, 2^a and G, 2^b.⁶⁶
- (b) Example of advance direction sign for route to be followed in order to turn left, where a left turn at the next intersection is prohibited: G, 3.

NOTE: Advance direction signs G, 1 may bear the symbols used on other signs informing road users of the characteristics of the route or of traffic conditions (for example: signs A, 2; A, 5; C, 3^c; C, 6; E, 5^a; F, 2).

⁶¹ See also point 23 of the Annex of the European Agreement.

⁶² See also point 23 of the Annex of the European Agreement.

⁶³ See corrigendum ECE/TRANS/WP.1/2003/3 Rev.4 Corr.1. The number previously attributed was F, 14.

⁶⁴ See corrigendum ECE/TRANS/WP.1/2003/3 Rev.4 Corr.1. The number previously attributed was F, 15.

⁶⁵ Additional text introduced in the Annex of the European agreement (see point 23).

⁶⁶ See also point 24 of the Annex of the European Agreement.

III. Direction signs

1. Examples of signs showing the direction of a place: G, 4^a; G, 4^b; G, 4^c and G, 5.⁶⁷
2. Examples of signs showing the direction of an airfield: G, 6^a; G, 6^b and G, 6^c.⁶⁸
3. Sign G, 7 shows the direction of a camping site.
4. Sign G, 8 shows the direction of a youth hostel.
5. Examples of signs showing the direction of a car parking more particularly intended for vehicles whose drivers wish to use means of public transport: G, 9^a and G, 9^b. The type of public transport may be indicated on the sign by an inscription or symbol.

NOTE: Direction signs G, 4; G, 5 and G, 6 may bear the symbols used on other signs informing road users of the characteristics of the route or traffic conditions (for example: signs A, 2; A, 5; C, 3^c; C, 6; E, 5^a; F,2)

IV. Confirmatory signs

Sign G, 10 is an example of a confirmatory sign.

Notwithstanding the provisions of Article 6, paragraph 1, of this Convention, this sign may be placed on the reverse side of another sign intended for traffic proceeding in the opposite direction.

V. Indication signs

1. Signs indicating the number and direction of traffic lanes

Signs such as G, 11^a; G, 11^b and G, 11^c shall be used to notify drivers on the number and direction of traffic lanes. They must comprise the same number of arrows as the number of lanes allocated to traffic in the same direction; they may also indicate lanes allocated to oncoming traffic.

2. Signs indicating closure of a traffic lane

Signs such as G, 12^a and G, 12^b shall indicate to drivers closure of a traffic lane.

3. "NO THROUGH ROAD" sign⁶⁹

Sign G, 13, "NO THROUGH ROAD", placed at the entry to a road, shall mean that there is no throughway.

4. "GENERAL SPEED LIMITS" sign

Sign G, 14, "GENERAL SPEED LIMITS", shall be used, especially near national frontiers, to notify the general speed limits in force in a country or in a subdivision of that country. The name or distinguishing sign of the country, possibly accompanied by the national emblem, shall be placed at the top of the sign. On the sign the general speed limits in force in a country will be shown in the following order: (1) in built-up areas; (2) outside built-up areas; (3) on motorways.

⁶⁷ See also point 25 of the Annex of the European Agreement.

⁶⁸ See also point 25 of the Annex of the European Agreement.

⁶⁹ See also point 26 of the Annex of the European Agreement.

If appropriate, the symbol of sign E, 6a, "Road for motor vehicles", may be used to indicate the general speed limit on roads for motor vehicles.

The border of the sign and its upper part shall be in blue; the country name and the ground of the three squares shall be in white. The symbols used in the upper and central squares shall be in black and the symbol in the central square shall have an oblique red line across it.

5. "ROAD OPEN OR CLOSED" sign

(a) Sign G, 15, "ROAD OPEN OR CLOSED", shall be used to show whether a mountain road, particularly a section leading over a pass, is open or closed; the sign shall be placed at the entry to the road or roads leading to the section in question.

The name of the section of road (or pass) shall be inscribed in white. On the sign shown, the name "Furka" is given as an example.

Panels 1, 2 and 3 shall be removable.

(b) If the section of road is closed, panel 1 shall be red and shall bear the inscription "CLOSED"; if the section is open, panel 1 shall be green and shall bear the inscription "OPEN". The inscriptions shall be in white and preferably in several languages.

(c) Panels 2 and 3 shall have a white ground with inscriptions and symbols in black.

If the section of road is open, panel 3 shall remain blank and panel 2, according to the state of the road, shall either be blank, or display sign D, 9, "SNOW CHAINS COMPULSORY", or display symbol G, 16, "CHAINS OR SNOW TYRES RECOMMENDED". This symbol shall be black.

If the section of road is closed, panel 3 shall show the name of the place up to which the road is open and panel 2 shall display, according to the state of the road, either the inscription "OPEN AS FAR AS", or symbol G, 16, or sign D, 9.

6. "ADVISORY SPEED" sign

Sign G, 17 "ADVISORY SPEED" shall be used to show the speed at which it is advisable to drive if circumstances permit and if the driver is not required to comply with a lower limit specific to his category of vehicle. The figure or range of figures appearing on the sign shall indicate the speed in the unit of measurement most commonly used to express the speed of vehicles in the country concerned. This unit may be specified on the sign.

7. Sign notifying advised itinerary for heavy vehicles

G, 18 "ADVISED ITINERARY FOR HEAVY VEHICLES"

8. Sign notifying an escape lane

Sign G, 19 "ESCAPE LANE" shall be used to indicate an escape lane on steep descent. This sign, with a plate showing distance to the escape lane, should be placed in conjunction with sign A, 2 at the top of the descent, where the danger zone begins and at the entry to the escape lane. Depending on the length of the descent the sign should be repeated as necessary, again with a distance plate.

The symbol may be varied corresponding to the siting of the escape lane in relation to the road concerned.

9. Signs notifying a pedestrian overpass or underpass

- (a) Sign G, 20 is used to indicate a pedestrian overpass or underpass.
- (b) Sign G, 21 is used to indicate an overpass or underpass without steps. The symbol for handicapped persons may also be used on this sign.

10. Signs notifying an exit from a motorway

Signs G, 22^a; G, 22^b and G, 22^c are examples of advance signs for notifying an exit from a motorway. These signs shall bear the indication of a distance to the exit from a motorway, as determined by domestic legislation, provided that signs bearing respectively one and two oblique bars are set up at one third and two thirds of the distance between the sign bearing three oblique bars and the exit from a motorway.

11. Signs indicating emergency exits

- (a) The signs G, 23^a and G, 23^b indicate the location of emergency exits.
- (b) The signs G, 24^a, G, 24^b and G, 24^c are examples of signs to indicate the direction and distance of the nearest emergency exits. In tunnels, they shall be placed at a maximum distance of 50 m apart and at a height of 1 to 1.5 m on the sidewalls.
- (c) The signs G, 23 and G, 24 have a green ground and the symbols, arrows and distance indications are white or of a light colour.

Section H

ADDITIONAL PANELS

1. These panels shall have either a white or yellow ground and a black, dark blue or red rim, in which case the distance or length or symbol shall be inscribed in black or dark blue; or a black or dark blue ground and a white, yellow or red rim, in which case the distance or length or symbol shall be inscribed in white or yellow.

⁷⁰ See footnote

2. (a) Additional panels H, 1 show the distance from the sign to the beginning of the dangerous section of road or of the zone to which the regulation applies.

(b) Additional panels H, 2 show the length of the dangerous section of road or of the zone to which the regulation applies.

(c) Additional panels are placed under the signs. However, in the case of danger warning signs of model A^b, the information to be given on the additional panels may be inscribed on the lower part of the sign.

3. The additional panels H, 3 and H, 4 concerning parking prohibitions or restrictions are of models H, 3^a; H, 3^b and H, 3^c and H, 4^a; H, 4^b and H, 4^c respectively. (See: section C, para. 9 (c) of this annex).

4. Regulatory signs may be restricted to particular road users by displaying the symbol for their category. For example: H, 5^a and H, 5^b.

⁷⁰ Additional paragraph introduced in the Annex of the European Agreement (see point 27).

In cases where the regulatory sign is to be regarded as not applying to a certain category of road users this is indicated by the symbol for their category and by the term "except" in the language of the particular country. For example: H, 6. If necessary the symbol may be replaced by an inscription in that language.

5. To indicate parking space reserved for handicapped persons, panel H, 7 should be used with signs C, 18 or E, 14.

6. The additional panel H, 8 displays a diagram of the intersection in which broad strokes indicate priority roads and thin strokes indicate the roads on which signs B, 1 or B, 2 are set up.

7. To indicate that the section of road ahead is slippery because of ice or snow the additional panel H, 9 should be used.

NOTE APPROPRIATE TO THE WHOLE OF ANNEX I: In countries where traffic keeps to the left, signs and/or symbols shall be reversed as appropriate.

Annex 2**ROAD MARKINGS****Chapter I****GENERAL**

1. Road surface markings (road markings) should be of non-skid materials and should not protrude more than 6 mm above the level of the carriageway. Studs or similar devices used for marking should not protrude more than 1.5 cm above the level of the carriageway (or more than 2.5 cm in the case of studs incorporating reflex reflectors); they should be used in accordance with road traffic safety requirements.

Chapter II**LONGITUDINAL MARKINGS****A. DIMENSIONS**

2.⁷¹ The width of continuous or broken lines used for longitudinal markings should be at least 0.10 m.

3. The distance between two adjacent longitudinal lines (double line) should be between 0.10 m and 0.18 m.

4. A broken line shall consist of strokes of equal length separated by uniform gaps. The speed of vehicles on the section of road or in the area in question should be taken into account in determining the length of the strokes and of the gaps between them.

5.⁷² Outside built-up areas a broken line should consist of strokes between 2 m and 10 m long. The length of the strokes forming the approach line referred to in paragraph 23 of this Annex should be from two to three times the length of the gaps.

6.⁷³ In built-up areas, the length and spacing of the strokes should be less than they are outside built-up areas. The strokes may be reduced to 1 m. On certain main urban arteries where traffic moves fast, however, the characteristics of longitudinal markings may be the same as outside built-up areas.

B. TRAFFIC LANE MARKINGS⁷⁴

7. Traffic lanes shall be marked by broken lines, by continuous lines or by other appropriate means.

(i) Outside built-up areas

8. On two-way roads having two lanes, the centre line of the carriageway should be indicated by a longitudinal marking.⁷⁵ This marking shall normally consist of a broken line. Continuous lines should only be used for this purpose in special circumstances.

⁷¹ See also point 7 of the Annex of the Protocol on Road Markings

⁷² See also point 7 of the Annex of the Protocol on Road Markings

⁷³ See also point 7 of the Annex of the Protocol on Road Markings

⁷⁴ See also point 7 of the Annex of the Protocol on Road Markings

9.⁷⁶ On three-lane roads, the lanes should, as a general rule, be indicated by broken lines along sections where visibility is normal. In specific cases and in order to ensure greater traffic safety, continuous lines or broken lines adjacent to continuous lines may be used.

10.⁷⁷ On carriageways having more than three traffic lanes, the two directions of traffic should be separated by one continuous line or by two continuous lines, except in cases where the direction of traffic in the central lanes can be reversed. In addition, the traffic lanes should be marked by broken lines (diagrams 1a and 1b).

(ii) In built-up areas

11.⁷⁸ In built-up areas, the recommendations contained in paragraphs 8 to 10 of this Annex are applicable to two-way streets and to one-way streets with at least two traffic lanes.

⁷⁹ See footnote

12. Traffic lanes should be marked at points where the width of the roadway is reduced by kerbs, islands or directional islands.

13. At the approaches to major intersections (especially intersections where traffic is controlled), where the width is sufficient for two or more lines of vehicles, traffic lanes should be marked as shown in diagrams 2 and 3⁸⁰. In such cases, the lines marking the lanes may be supplemented with arrow markings (see para. 39 of this Annex).

⁸¹ See footnote

C. Markings for particular situations

(i) Use of continuous lines

14. In order to improve traffic safety, the broken centre lines at certain intersections (diagram 4) should be replaced or supplemented by a continuous line (diagrams 5 and 6)⁸².

15.⁸³ When it is necessary to prohibit the use of the part of the carriageway reserved for oncoming traffic at places where the range of vision is restricted (hill crest, bend in the road, etc.) or on sections where the carriageway is narrow or has some other peculiarity, restrictions should be imposed on sections where the range of vision is less than a certain minimum M, by means of a continuous line laid out in accordance with diagrams 7a to 16⁸⁴. In countries where the design of motor vehicles justifies it, the eye level of 1 m indicated in diagrams 7a to 10a may be raised to 1.20 m.

16.⁸⁵ The value to be adopted for M varies with road conditions. Diagrams 7a, 7b, 8a, 8b, 8c and 8d show, for two- and three-lane roads respectively, the design of the lines at a hill crest with a restricted range of vision. These diagrams correspond to the longitudinal section at the top of the

⁷⁵ See also point 7 of the Annex of the Protocol on Road Markings.

⁷⁶ See also point 7 of the Annex of the Protocol on Road Markings.

⁷⁷ See also point 7 of the Annex of the Protocol on Road Markings.

⁷⁸ See also point 7 of the Annex of the Protocol on Road Markings.

⁷⁹ Additional paragraph inserted in the Annex of the Protocol on Road Markings (see point 7).

⁸⁰ See also point 7 of the Annex of the Protocol on Road Markings.

⁸¹ Additional paragraph inserted in the Annex of the Protocol on Road Markings (see point 7).

⁸² See also point 7 of the Annex of the Protocol on Road Markings.

⁸³ See also point 7 of the Annex of the Protocol on Road Markings.

⁸⁴ The definition of range of vision used in this paragraph is the distance at which an object 1 metre (3 ft. 4 in.) above the surface of the carriageway can be seen by an observer on the road whose eye is also 1 metre (3 ft. 4 in.) above the carriageway.

⁸⁵ See also point 7 of the Annex of the Protocol on Road Markings.

same page and to a distance M specified in paragraph 24 below: A (or D) is the point where the range of vision becomes less than M, while C (or B) is the point where the range of vision again begins to exceed M⁸⁶.

17.⁸⁷ Where the sections AB and CD overlap, i.e. when forward visibility in both directions becomes greater than M before the crest of the hill is reached, the lines should be arranged in the same way, but the continuous lines alongside a broken line should not overlap. This is indicated in diagrams 9, 10a and 10b.

18.⁸⁸ Diagrams 11a and 11b show the position of the lines for the same case on a curve with restricted range of vision on a two-lane road.

19.⁸⁹ On three-lane roads two methods are possible. These are shown in diagrams 8a, 8b, 8c and 8d (or 10a and 10b). Diagram 8a (or 8b or 10a) should be used on roads carrying a substantial proportion of two-wheeled vehicles and diagrams 8c and 8d (or 10b) where the traffic consists mainly of four-wheeled vehicles. Diagram 11c shows the arrangement of the lines for the same case on a curve with restricted range of vision on a three-lane road.

20.⁹⁰ Diagrams 12, 13 and 14 show the lines which indicate narrowing of the carriageway.

21.⁹¹ In diagrams 8a, 8b, 8c, 8d, 10a and 10b, the inclination of the oblique transition lines to the centre line should not exceed 1/20.

22. In diagrams 13 and 14 which show the lines used to indicate a change in width of the available carriageway, as well as in diagrams 15, 16 and 17 which show obstacles necessitating a deviation from the continuous line (s), the inclination of the line (s) should preferably be less than 1/50 on fast roads and less than 1/20 on roads where speeds do not exceed 50 km/h (30 m.p.h.).⁹² In addition, the oblique continuous lines should be preceded, in the direction to which they apply, by a continuous line parallel to the centre line of the roadway, the length of the continuous line being the distance covered in one second at the driving speed adopted.

23.⁹³ When it is not necessary to mark the traffic lanes by broken lines on a normal section of road, the continuous line should be preceded by an approach line consisting of a broken line, for a distance of at least 50 m, depending on the normal speed of the vehicles using the road. Where the traffic lanes are marked by broken lines on a normal section of road, the continuous line should also be preceded by an approach line for a distance of at least 50 m, depending on the normal speed of the vehicles using the road. The marking may be supplemented by one or more arrows showing drivers which lane they should take.

⁸⁶ The marking between A and D shown in diagrams 7a and 7b may be replaced by a single continuous centre line, without a broken line alongside, preceded by a broken centre line consisting of at least three strokes. Nevertheless, this simplified arrangement should be used with caution and only in exceptional cases, since it prevents the driver from overtaking for a certain distance even though the range of vision is adequate. It is desirable to avoid using both methods on the same route or on the same type of route in the same area, as this may lead to confusion.

⁸⁷ See also point 7 of the Annex of the Protocol on Road Markings.

⁸⁸ See also point 7 of the Annex of the Protocol on Road Markings.

⁸⁹ See also point 7 of the Annex of the Protocol on Road Markings.

⁹⁰ See also point 7 of the Annex of the Protocol on Road Markings.

⁹¹ See also point 7 of the Annex of the Protocol on Road Markings.

⁹² See also point 7 of the Annex of the Protocol on Road Markings.

⁹³ See also point 7 of the Annex of the Protocol on Road Markings.

(ii) Conditions for the use of continuous lines

24. The choice of range of vision to be used in determining the sections on which a continuous line is or is not desirable, and the choice of the length of the line, is bound to be a compromise. The following table gives the recommended value of M for various approach speeds:⁹⁴

| <u>Approach speed</u> | <u>Range of values of M</u> |
|-----------------------|-----------------------------|
| 100 km/h (60 m.p.h.) | 160 m to 320 m |
| 80 km/h (50 m.p.h.) | 130 m to 260 m |
| 65 km/h (40 m.p.h.) | 90 m to 180 m |
| 50 km/h (30 m.p.h.) | 60 m to 120 m |

25. For speeds not given in the preceding table the value of M should be calculated by interpolation or extrapolation.

D. Border lines indicating the limits of the carriageway

26. The limits of the carriageway shall preferably be marked by continuous lines. Studs, buttons or reflex reflectors may be used in conjunction with these lines.⁹⁵

E. Marking of obstructions

27.⁹⁶ Diagrams 15, 16 and 17 show the markings to be used near an island or any other obstruction on the carriageway.

F. Guidelines for turning vehicles

28.⁹⁷ At certain intersections it is desirable to show drivers how to turn left, in countries with right-hand traffic, or how to turn right in countries with left-hand traffic.

G. Road markings for a lane reserved for certain categories of vehicle

28 *bis*. The marking of lanes reserved for certain categories of vehicle shall be by means of lines which should be clearly distinguished from other continuous or broken lines of the carriageway, notably by being wider and with less space between strokes. With respect to a lane reserved primarily for buses, the word "BUS" or the letter "A" shall be marked on the reserved lane wherever necessary and specifically at the beginning of the lane and after intersections. Diagrams 28a and 28b show examples of markings for a lane reserved for regular public transport service vehicles.

Chapter III

TRANSVERSE MARKINGS

A. GENERAL

29. Because of the angle at which the driver sees markings on the carriageway, transverse markings shall be wider than longitudinal markings.

⁹⁴ The approach speed used in this calculation is the speed which 85 per cent of the vehicles do not exceed, or the design speed if it is higher.

⁹⁵ Additional sentences introduced in the Annex of the Protocol on Road Markings (see point 7).

⁹⁶ See also point 7 of the Annex of the Protocol on Road Markings.

⁹⁷ See also point 7 of the Annex of the Protocol on Road Markings.

B. STOP LINES

30. The minimum width of a stop line shall be 0.20 m and the maximum 0.60 m. A width of 0.30 m is recommended.⁹⁸

31. When used in conjunction with a STOP sign, the stop line should be placed in such a position that a driver who stops immediately behind the line has the clearest possible view of the traffic on the other arms of the intersection consistent with the requirements of other vehicular and pedestrian traffic.

32.⁹⁹ Stop lines may be supplemented by longitudinal lines (diagrams 18 and 19). They may also be supplemented by the word "STOP" inscribed on the carriageway as shown in the examples given in diagrams 20 and 21. The distance between the top of the letters of the word "STOP" and the stop line should be between 2 m and 25 m.

C. LINES INDICATING POINTS AT WHICH DRIVERS MUST GIVE WAY

33.¹⁰⁰ The minimum width of these lines should be 0.20 m and the maximum width 0.60 m; if there are two lines, the distance between them should be at least 0.30 m. The line may be replaced by triangles marked side by side on the ground with their vertices pointing towards the driver who is required to give way. The bases of these triangles should measure at least 0.40 m but not more than 0.60 m and their height should be at least 0.60 m but not more than 0.70 m.

34. Transverse marking (s) should be placed in the same positions as the stop lines referred to in paragraph 31 of this Annex.

35.¹⁰¹ The marking (s) referred to in paragraph 34 above may be supplemented by a triangle drawn on the carriageway as shown in the example given in diagram 22. The distance between the base of the triangle and the transverse marking should be between 2 m and 25 m. The base of the triangle shall be at least 1 m; its height shall be three times its base.

36. This transverse marking may be supplemented by longitudinal lines.

D. PEDESTRIAN CROSSINGS

37.¹⁰² The space between the stripes marking a pedestrian crossing should be at least equal to the width of the stripes and not more than twice that width: the width of a space and a stripe together should be between 1 m and 1.40 m. The minimum width recommended for pedestrian crossings is 2.5 m on roads on which the speed limit is 60 km/h, and 4 m on roads in which the speed limit is higher or there is no speed limit.

E. CYCLIST CROSSINGS

38.¹⁰³ Cyclist crossings should be indicated by two broken lines. The broken line should preferably be made up of squares (0.40-0.60) x (0.40-0.60) m. The distance between the squares should be 0.40-0.60 m. The width of the crossings should be not less than 1.80 m. Studs and buttons are not recommended.

⁹⁸ See also point 7 of the Annex of the Protocol on Road Markings.

⁹⁹ See also point 7 of the Annex of the Protocol on Road Markings.

¹⁰⁰ See also point 7 of the Annex of the Protocol on Road Markings.

¹⁰¹ See also point 7 of the Annex of the Protocol on Road Markings.

¹⁰² See also point 7 of the Annex of the Protocol on Road Markings.

¹⁰³ See also point 7 of the Annex of the Protocol on Road Markings.

Chapter IV

OTHER MARKINGS

A. ARROW MARKINGS

39.¹⁰⁴ On roads having sufficient traffic lanes to separate vehicles approaching an intersection, the lanes which traffic should use may be indicated by arrow markings on the surface of the carriageway (diagrams 2, 3, 19 and 23). Arrows may also be used on a one-way road to confirm the direction of traffic. The arrow should not be less than 2 m long. They may be supplemented by word markings on the carriageway.

B. OBLIQUE PARALLEL LINES

40.¹⁰⁵ Diagrams 24 and 25 give examples of areas which vehicles should not enter.

C. WORD MARKINGS

41. Word markings on the carriageway may be used for the purpose of regulating traffic or warning or guiding road users. The words used should preferably be either place names, highway numbers or words which are easily understandable internationally (e.g. "Stop", "Bus", "Taxi").

42.¹⁰⁶ The letters should be considerably elongated in the direction of traffic movement because of the small angle at which they are seen by approaching drivers (diagram 20).

43.¹⁰⁷ Where approach speeds exceed 50 km/h (30 m.p.h.), the letters should be at least 2.5 m in height.

D. STANDING AND PARKING REGULATIONS

44. Standing and parking restrictions may be indicated by markings on the kerbs or on the carriageway. Parking space limits may be indicated on the surface of the carriageway by appropriate lines.

E. MARKINGS ON THE CARRIAGEWAY AND ON ADJACENT STRUCTURES

(i) Markings indicating parking restrictions

45.¹⁰⁸ Diagram 26 gives an example of a zigzag line.

(ii) Marking of obstructions

46.¹⁰⁹ Diagram 27 gives an example of a marking on an obstacle.

¹⁰⁴ See also point 7 of the Annex of the Protocol on Road Markings.

¹⁰⁵ See also point 7 of the Annex of the Protocol on Road Markings.

¹⁰⁶ See also point 7 of the Annex of the Protocol on Road Markings.

¹⁰⁷ See also point 7 of the Annex of the Protocol on Road Markings.

¹⁰⁸ See also point 7 of the Annex of the Protocol on Road Markings.

¹⁰⁹ See also point 7 of the Annex of the Protocol on Road Markings.

DIAGRAMS OF ANNEX 2

Diagram 1 a
Diagramme 1 a
Диаграмма 1 а



Diagram 1 b
Diagramme 1 b
Диаграмма 1 б

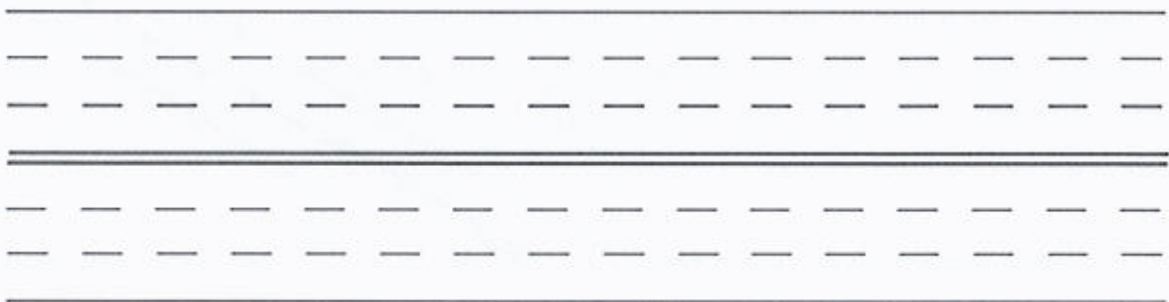

Diagram 2
Diagramme 2
Диаграмма 2

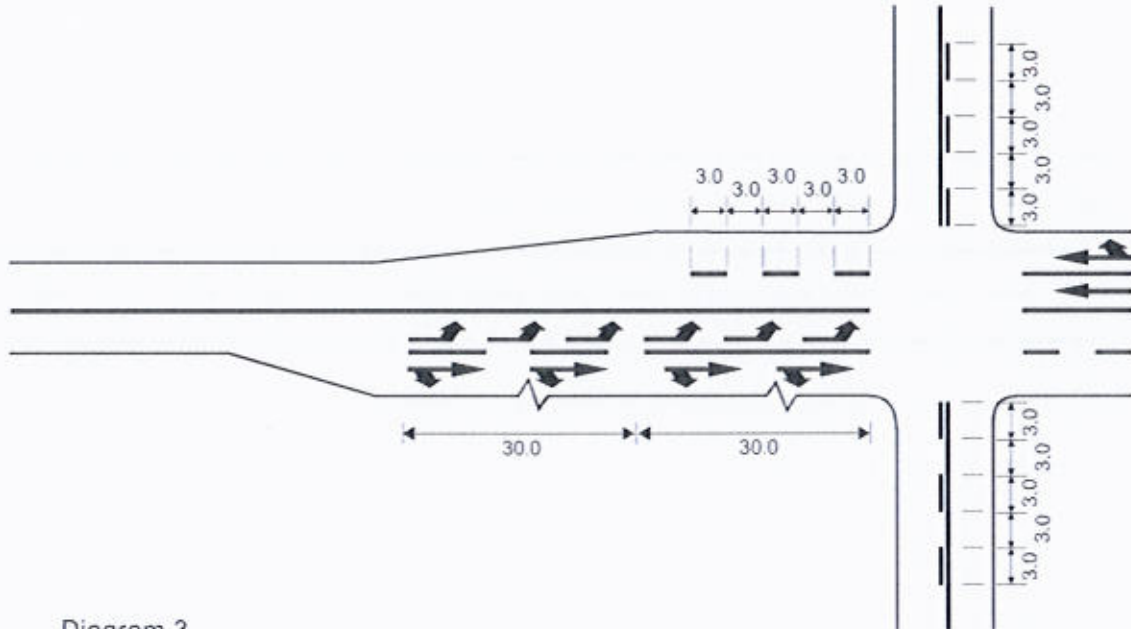

Diagram 3
Diagramme 3
Диаграмма 3

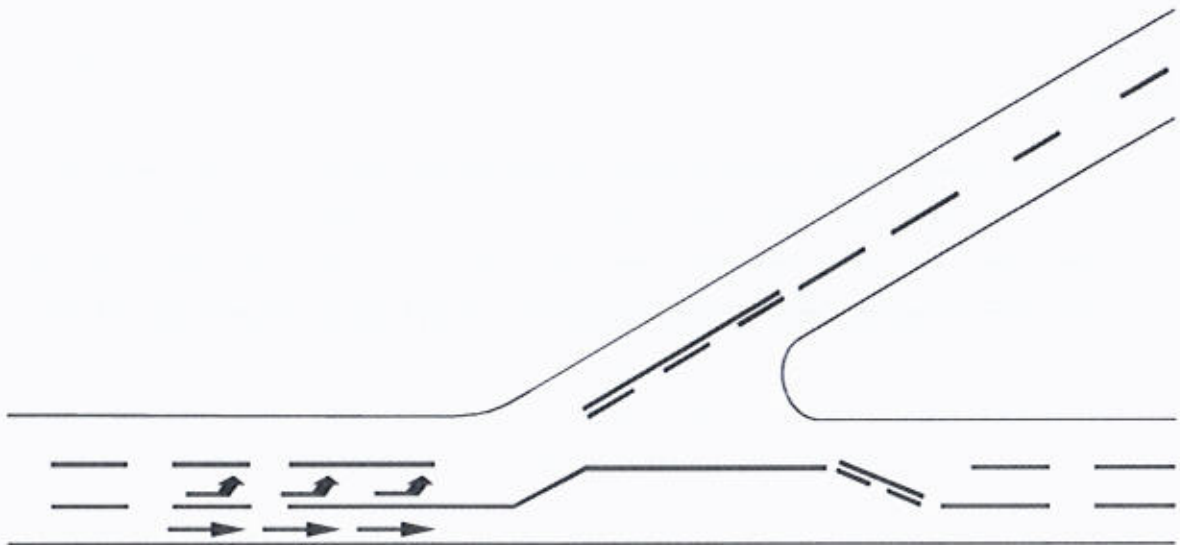

Diagram 4
Diagramme 4
Диаграмма 4

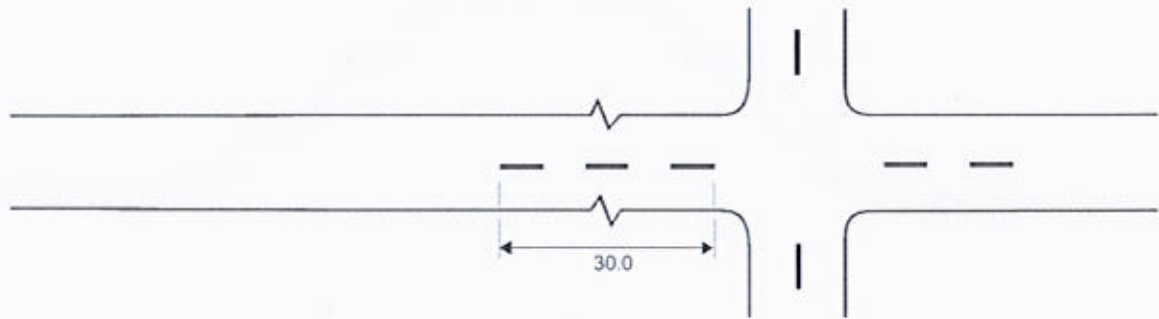

Diagram 5
Diagramme 5
Диаграмма 5

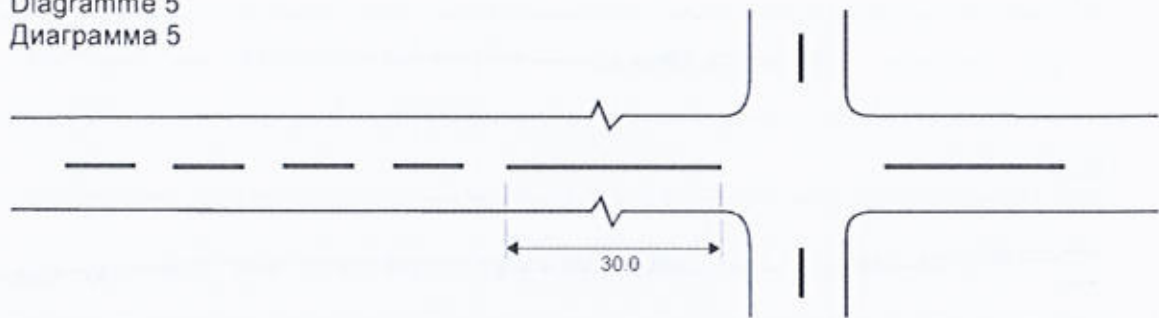

Diagram 6
Diagramme 6
Диаграмма 6

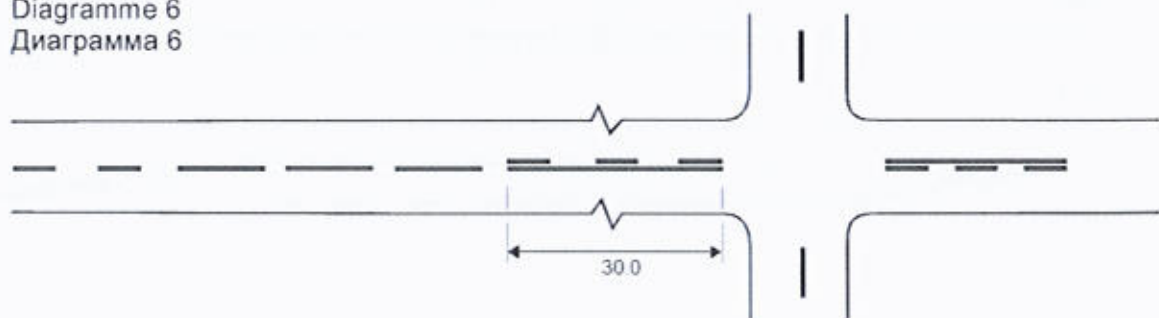
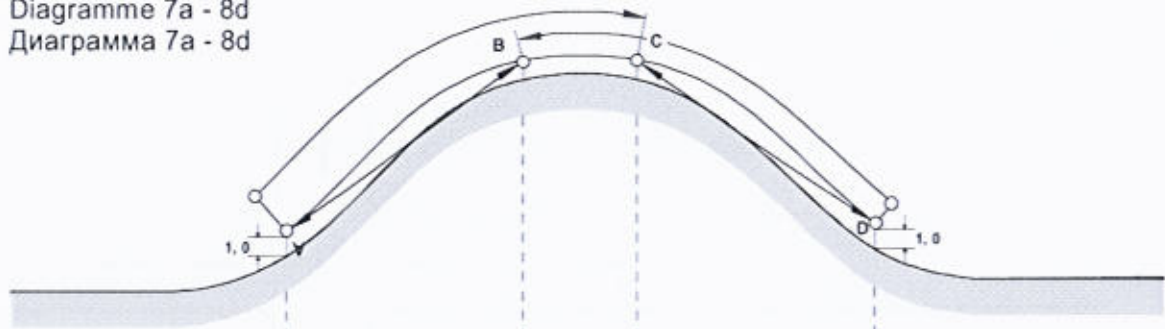
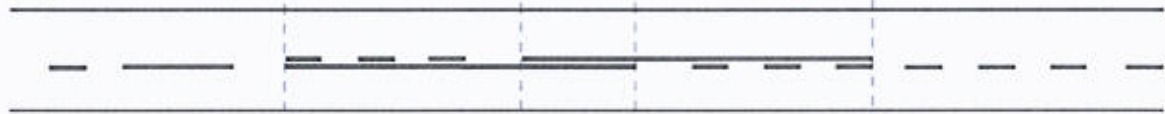

Diagram 7a - 8d
 Diagramme 7a - 8d
 Диаграмма 7а - 8d



(7a)



(7b)

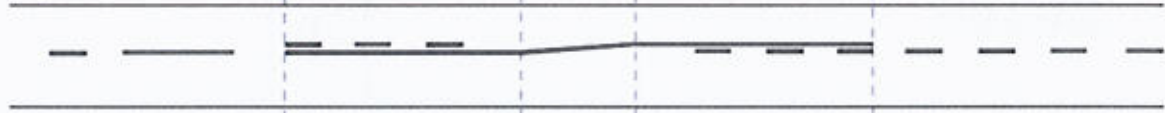

(8a)

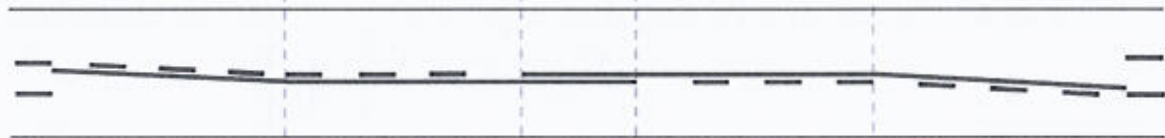

(8b)

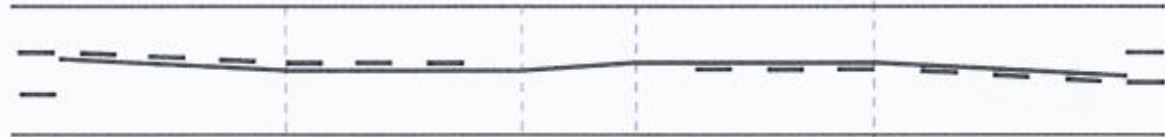

(8c)

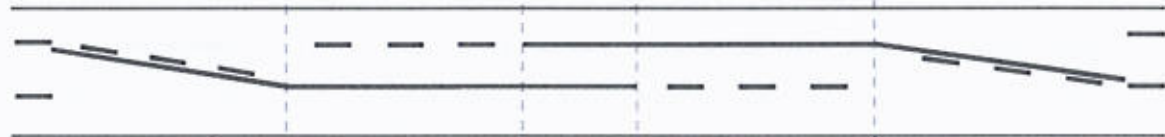

(8d)

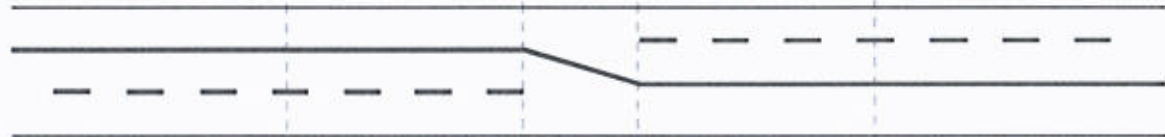

Diagram 9 - 10b
Diagramme 9 - 10b
Диаграмма 9 - 10b

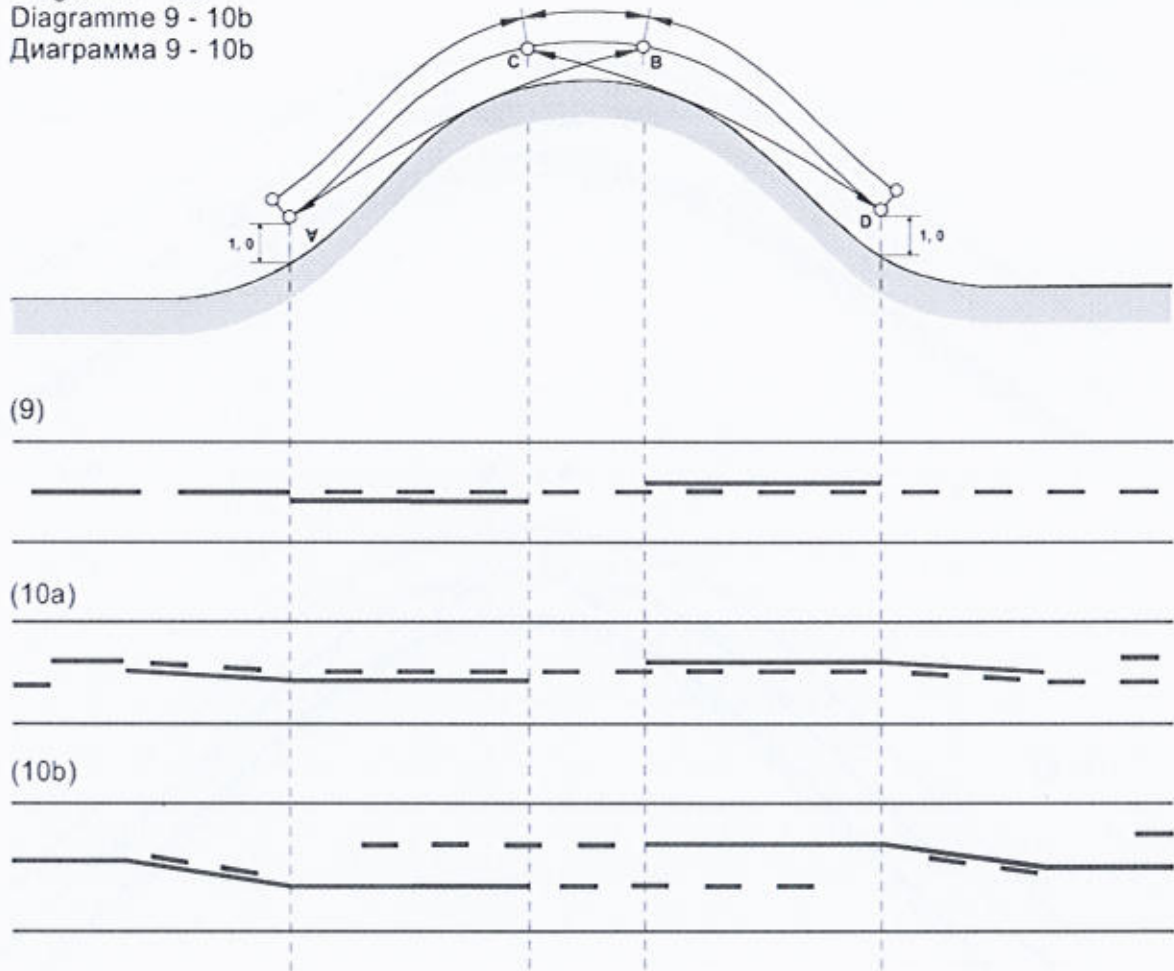

Diagram 11a - 11c
Diagramme 11a - 11c
Диаграмма 11a - 11c

(11 a)

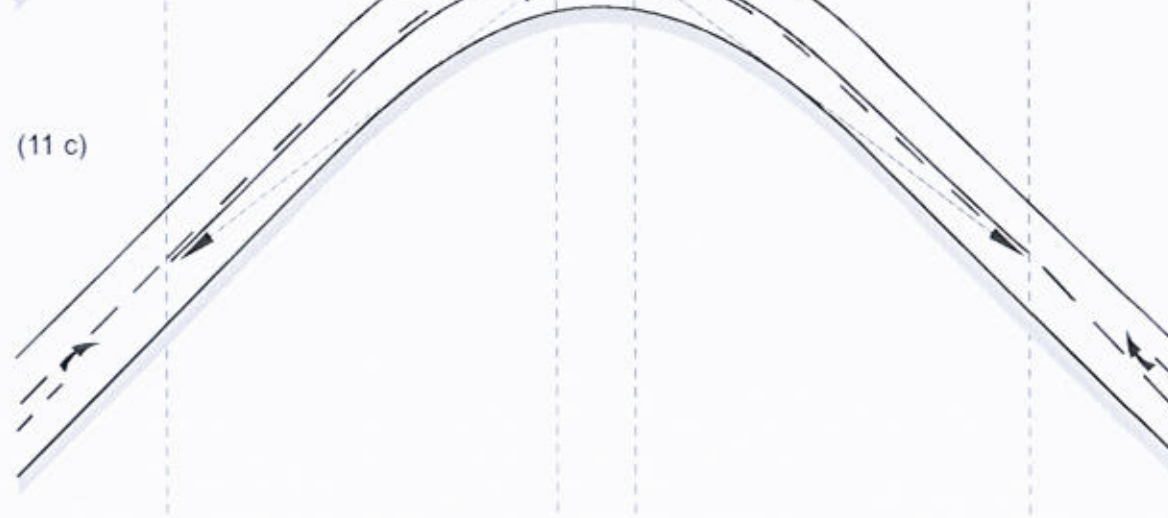
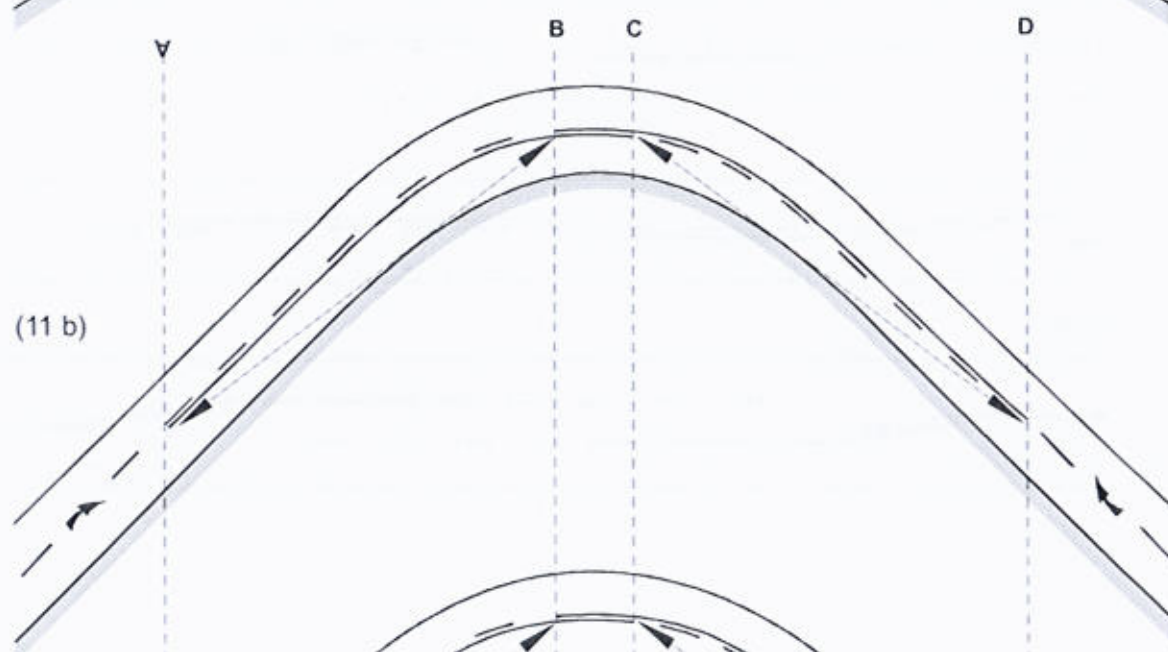
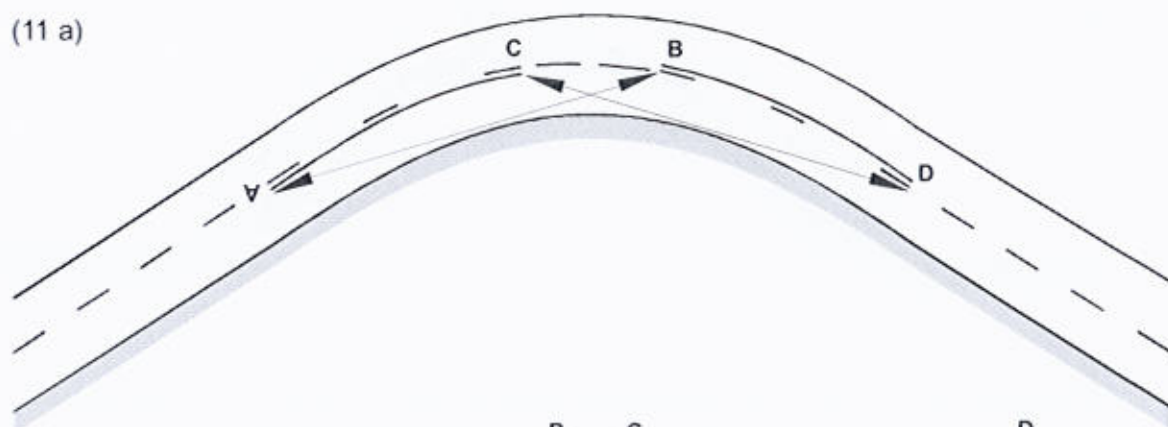
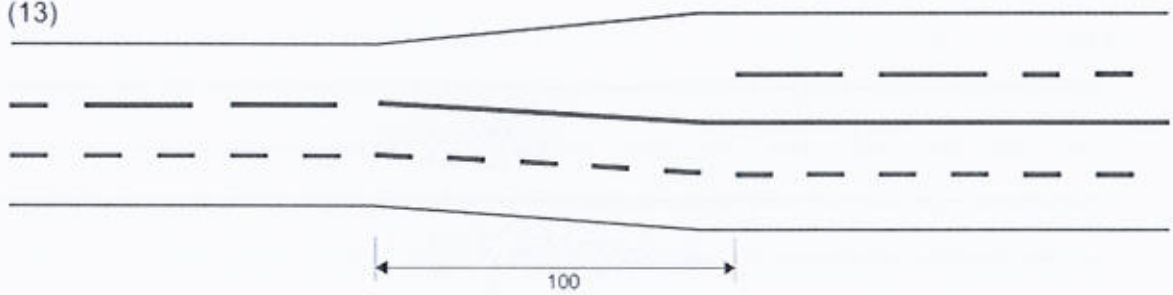

Diagram 12 - 15
Diagramme 12 - 15
Диаграмма 12 - 15

(12)



(13)



(14)



(15)

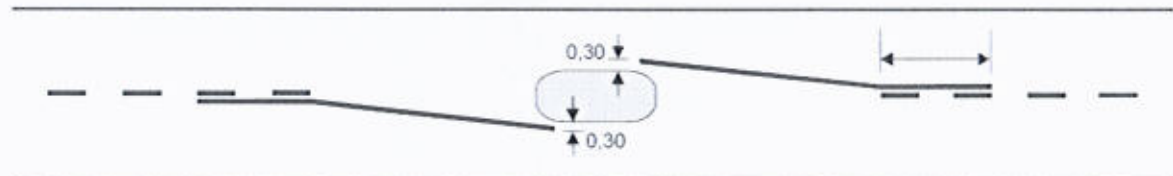
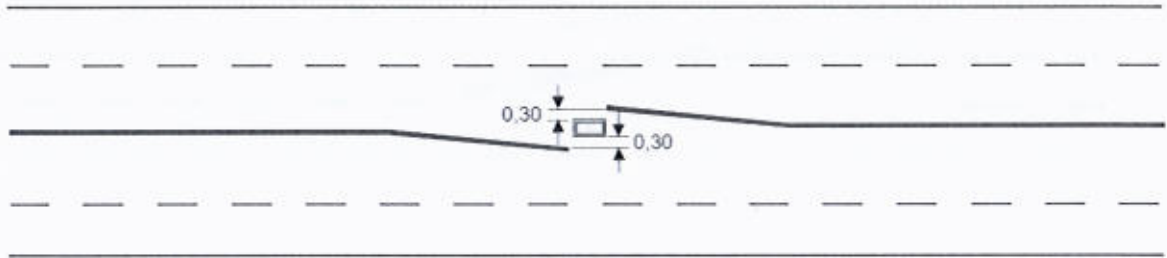
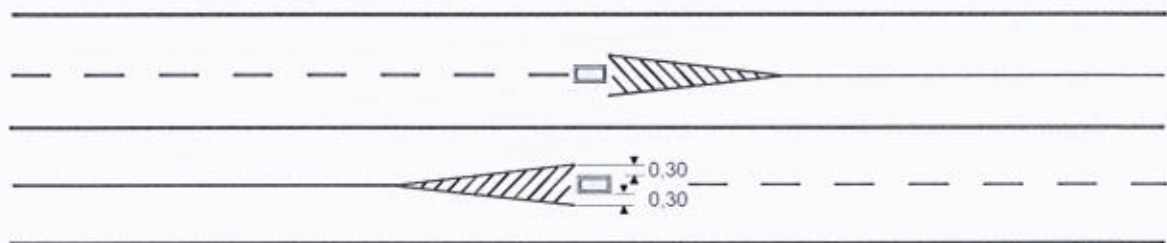

Diagram 16 - 18
Diagramme 16 - 18
Диаграмма 16 - 18

(16)



(17)



(18)

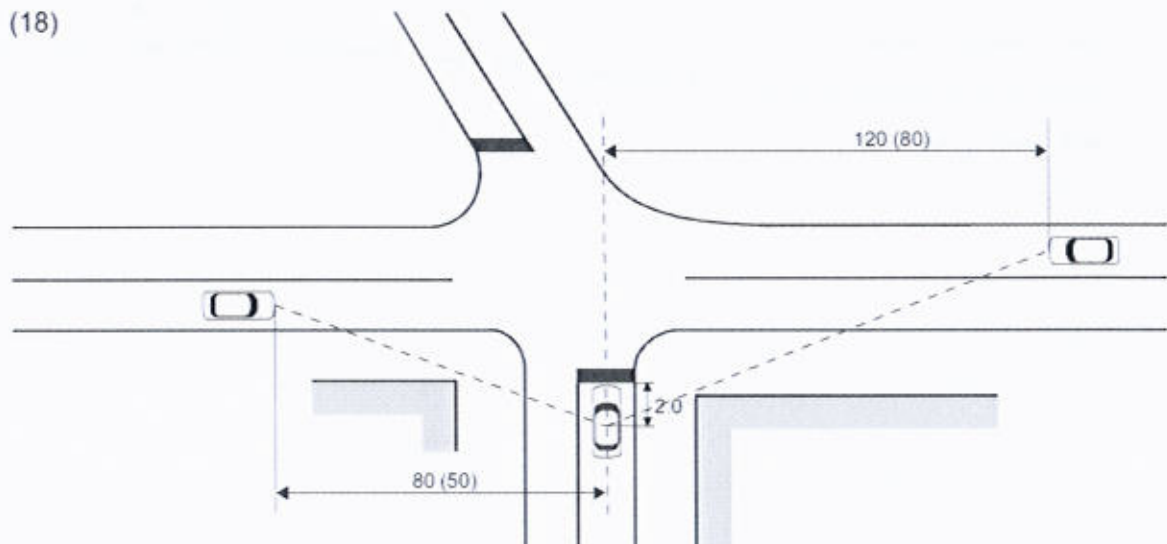

Diagram 19
Diagramme 19
Диаграмма 19

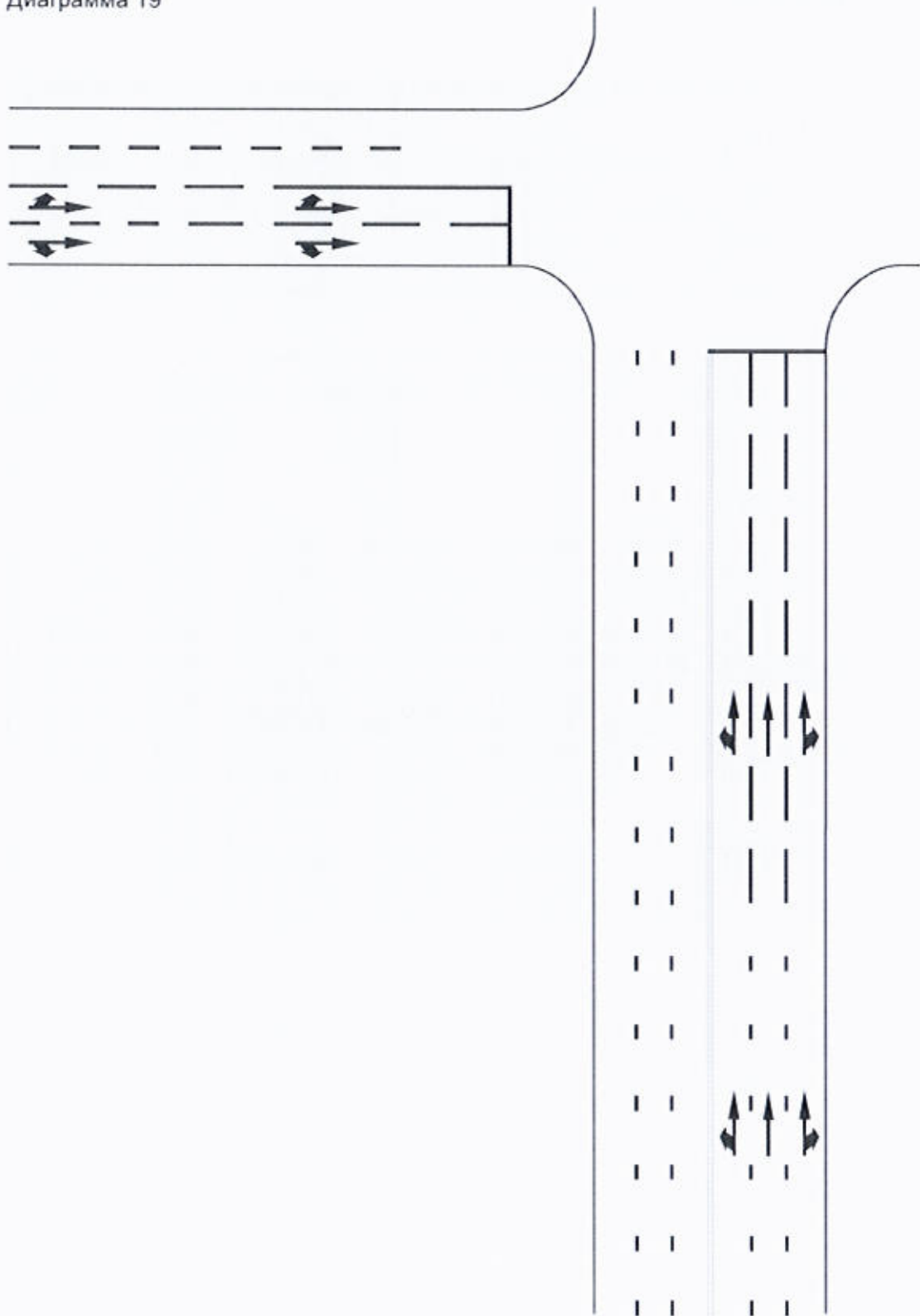

Diagram 20
Diagramme 20
Диаграмма 20

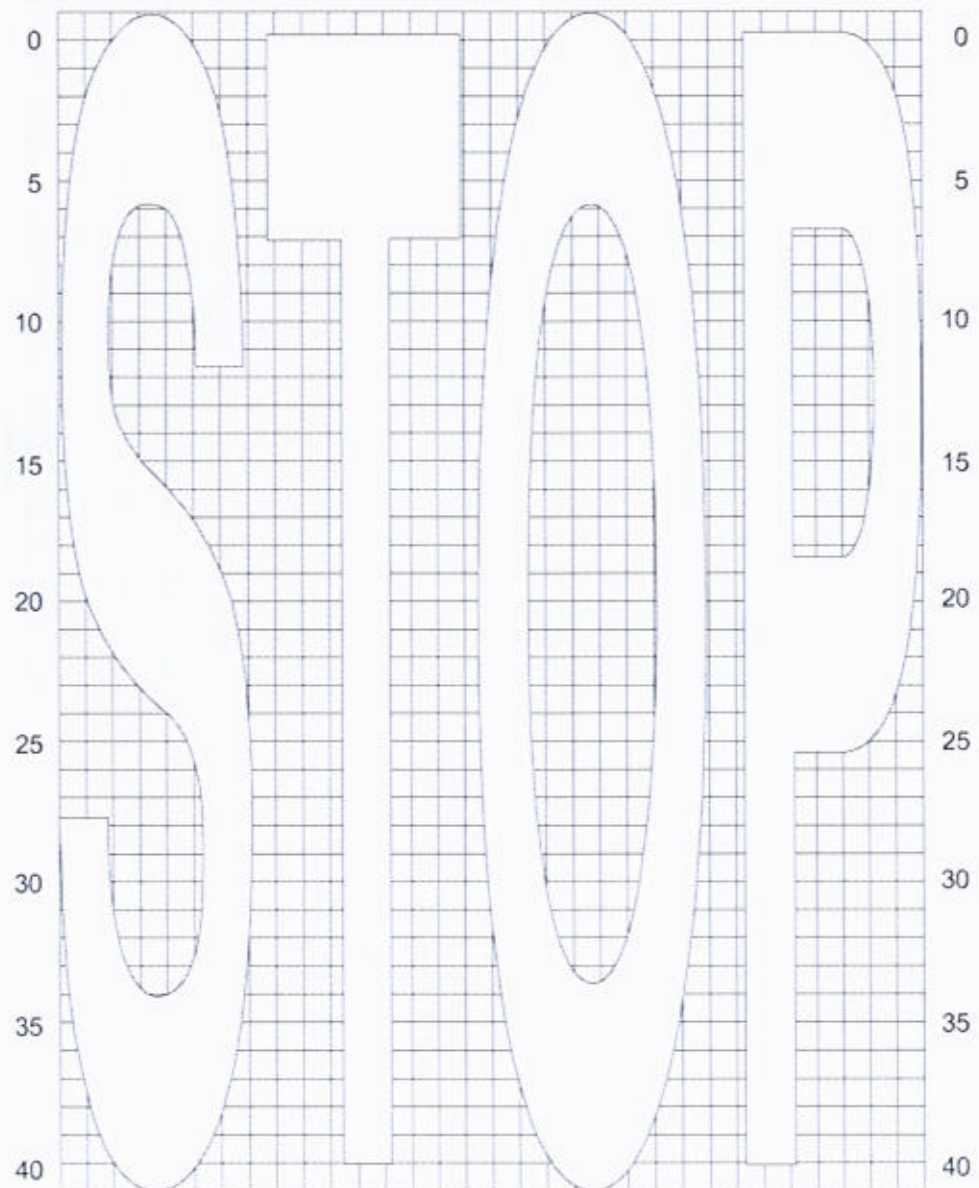
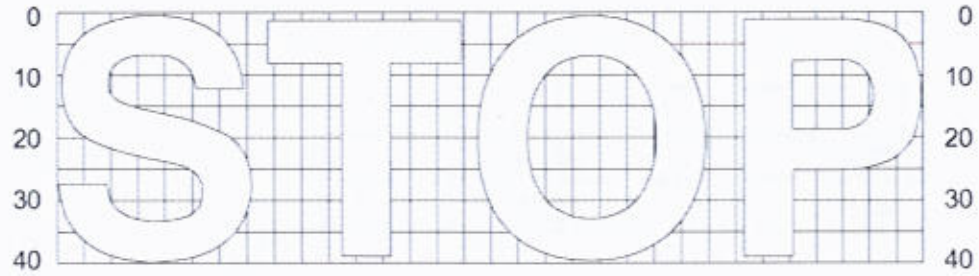

Diagram 21
Diagramme 21
Диаграмма 21

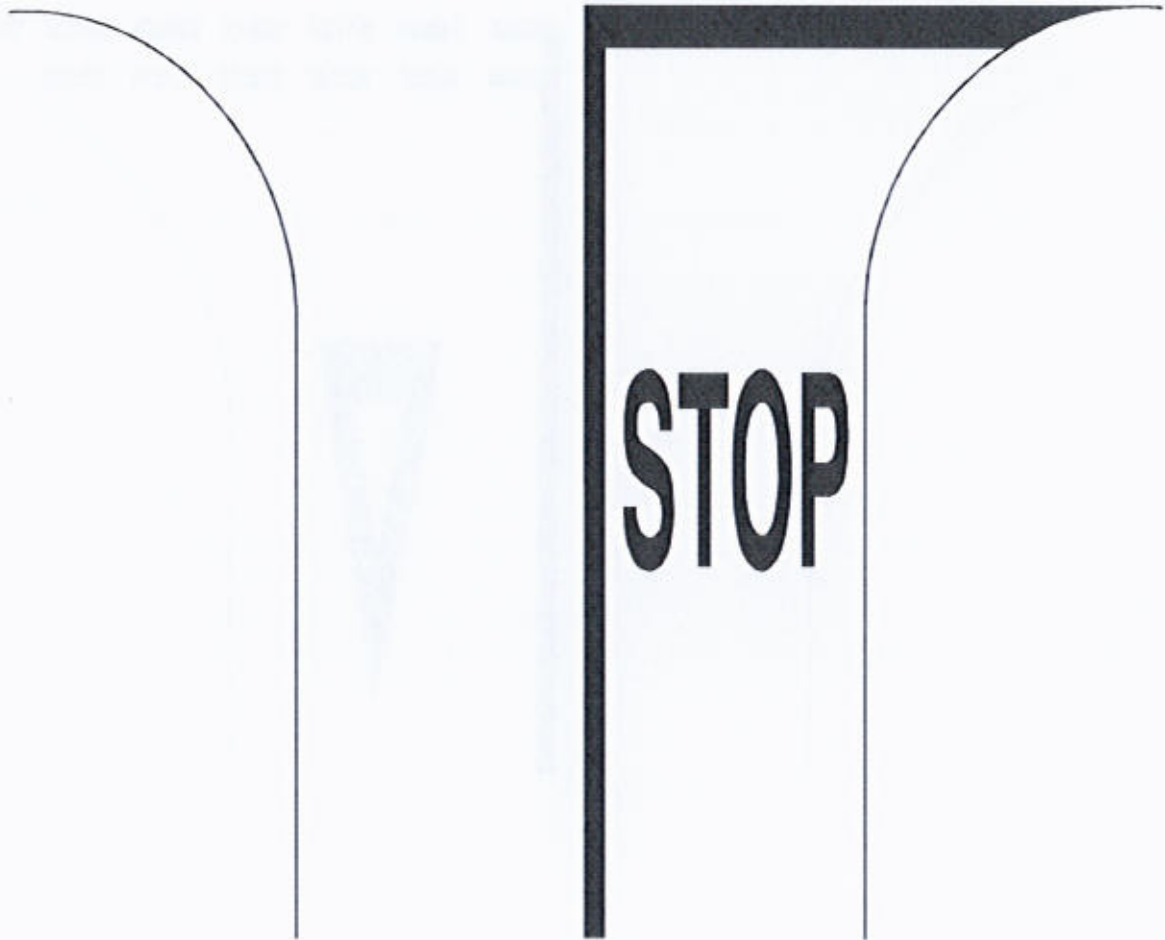

Diagram 22
Diagramme 22
Диаграмма 22

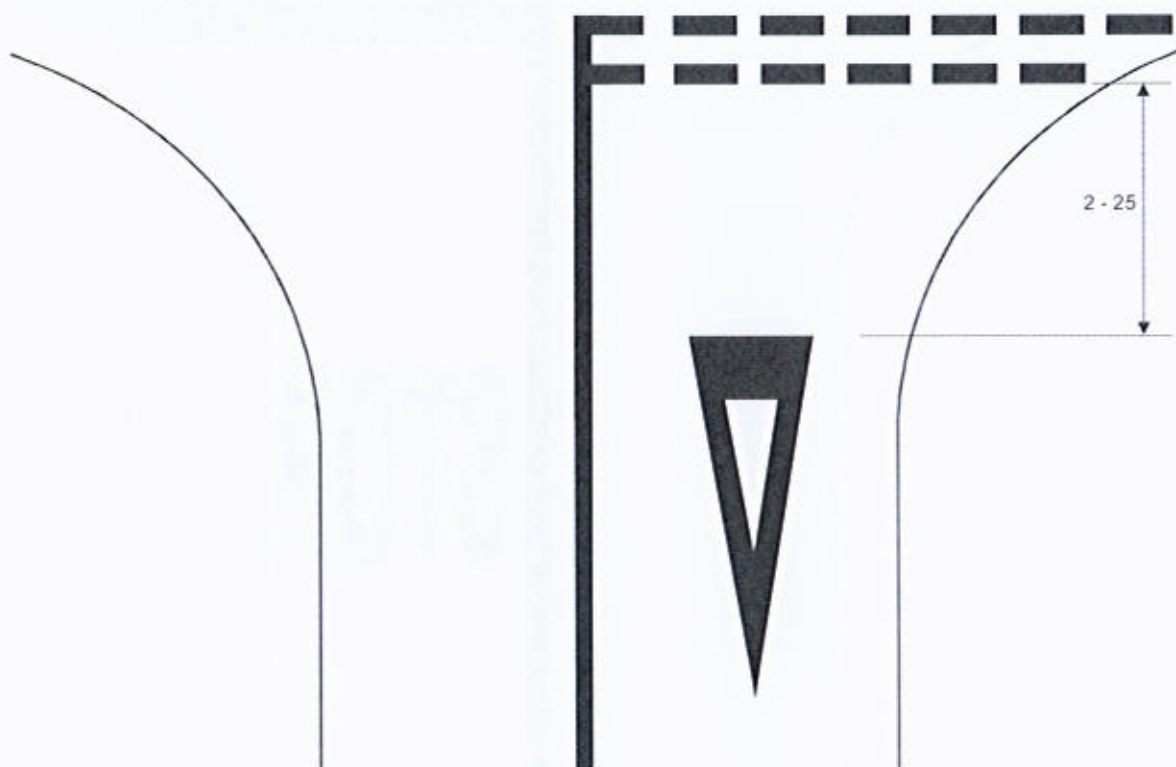

Diagram 23
Diagramme 23
Диаграмма 23

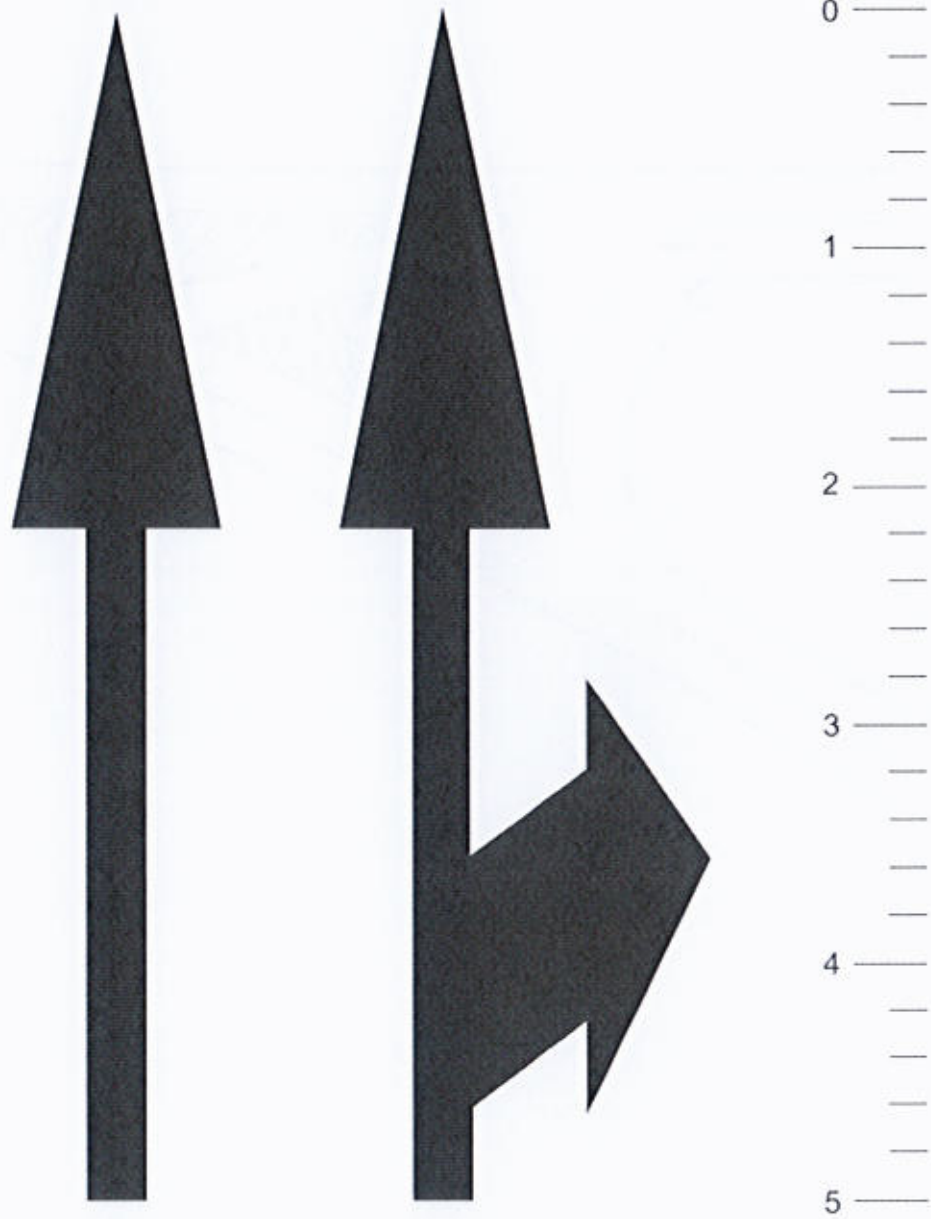

Diagram 24
Diagramme 24
Диаграмма 24

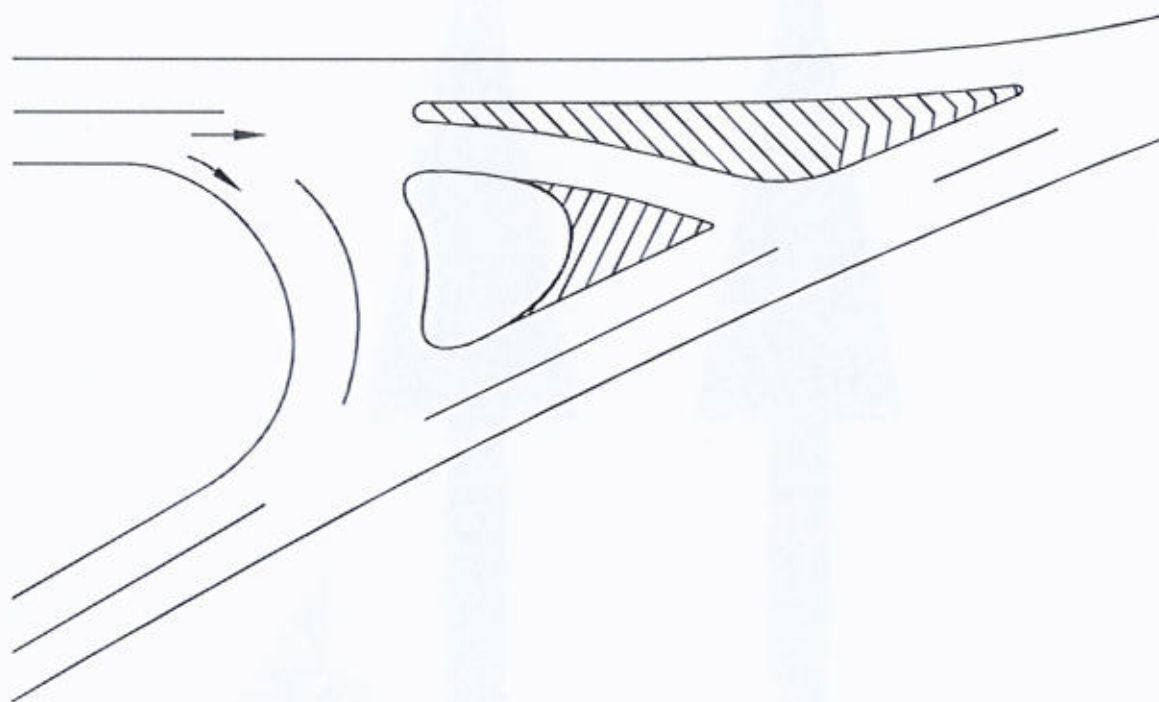

Diagram 25
Diagramme 25
Диаграмма 25



Diagram 26
Diagramme 26
Диаграмма 26



Diagram 27
Diagramme 27
Диаграмма 27

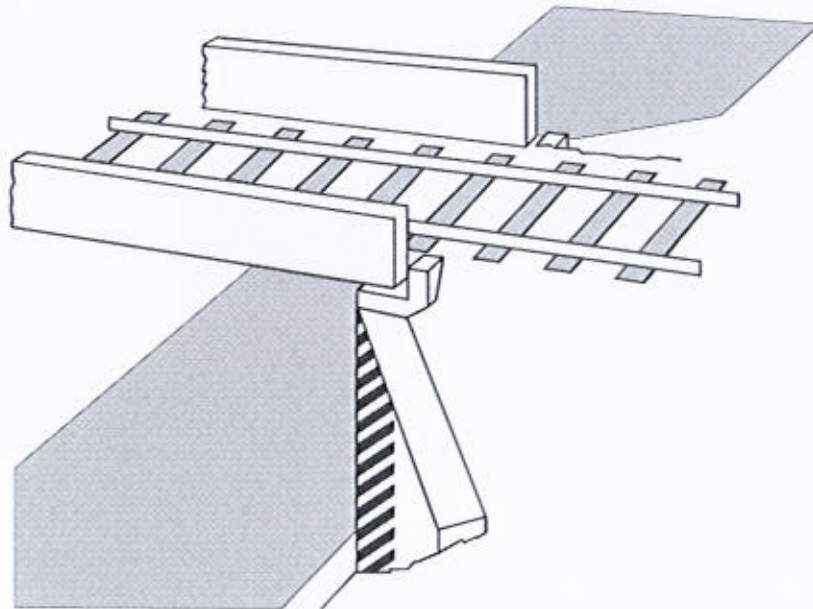
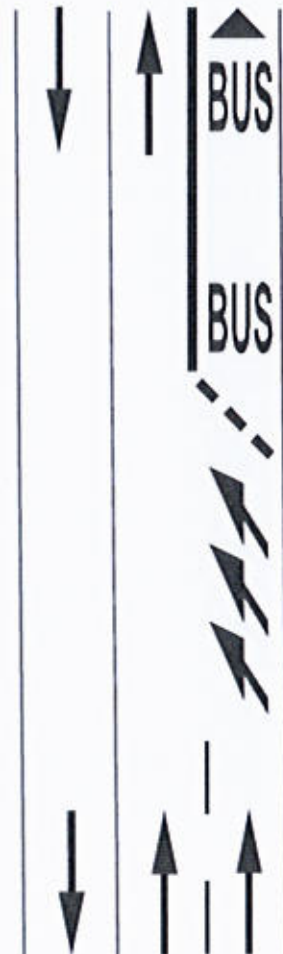
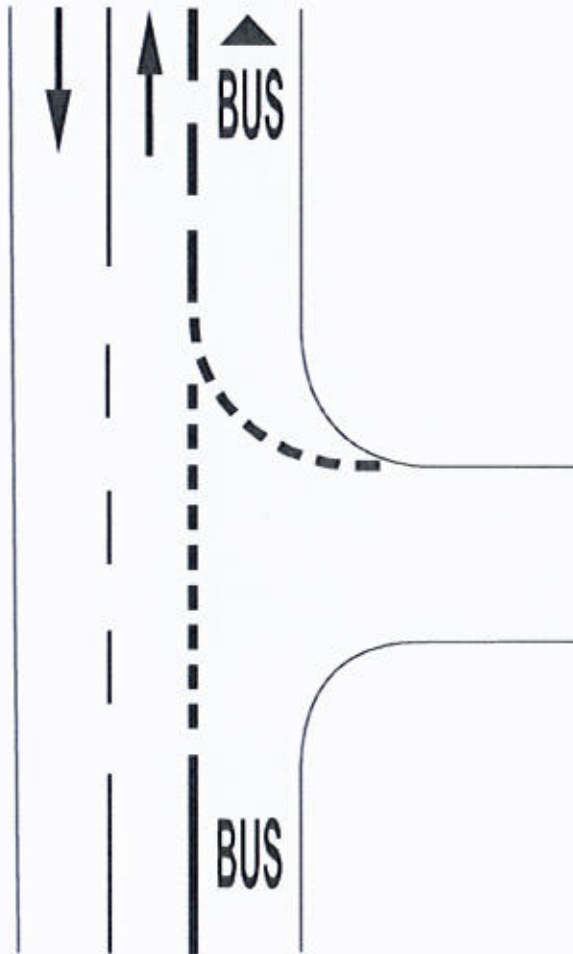

Diagram 28 a
Diagramme 28 a
Диаграмма 28 а

Diagram 28 b
Diagramme 28 b
Диаграмма 28 b



Annex 3

REPRODUCTION IN COLOUR OF SIGNS, SYMBOLS AND PANELS REFERRED TO IN ANNEX 1



A^a

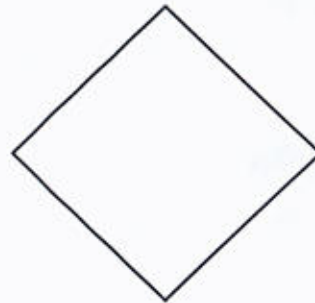

A^b



A, 1^a



A, 1^b



A, 1^c



A, 1^d



A, 2^a



A, 2^b



A, 2^c



A, 2^d



A, 3^a



A, 3^b



A, 3^c



A, 3^d



A, 4^a

A, 4^b

A, 5



A, 6

A, 7^aA, 7^bA, 7^c

A, 8



A, 9

A, 10^aA, 10^bA, 11^aA, 11^bA, 12^aA, 12^b

A, 13



A, 14

A, 15^aA, 15^b

A, 16



A, 17^b



A, 17^a



A, 17^c



A, 18^a



A, 18^b



A, 18^c



A, 18^d



A, 18^e



A, 18^f



A, 18^g



A, 19^a



A, 19^b

A, 19^c

A, 20

A, 21^aA, 21^b

A, 22



A, 23



A, 24



A, 25

A, 26^aA, 26^b

A, 27

A, 28^aA, 28^bA, 28^c

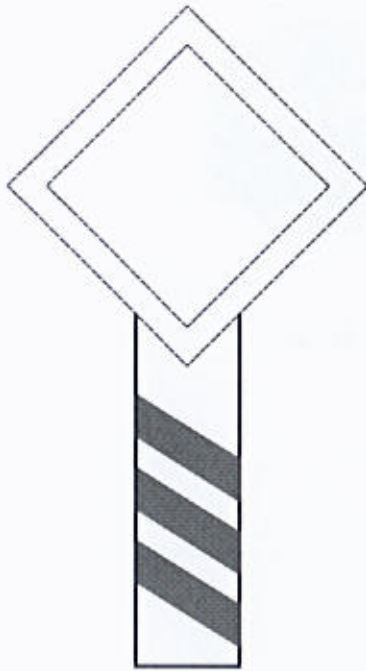

A, 29^a

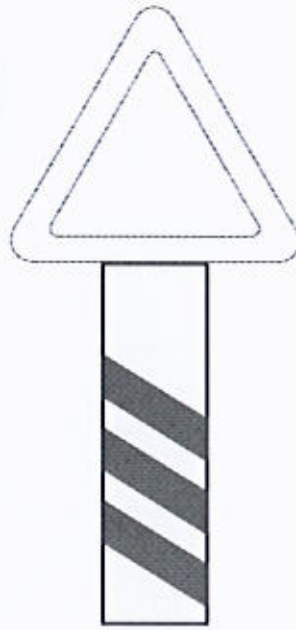

A, 29^b



A, 29^c



A, 30



A, 31



A, 32



B, 1



B, 2^a



B, 2^b

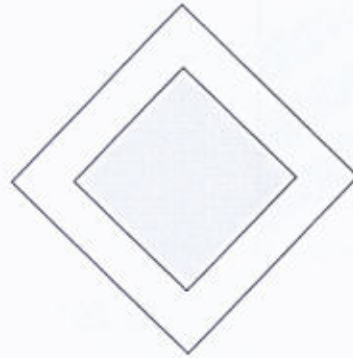

B, 3



B, 4

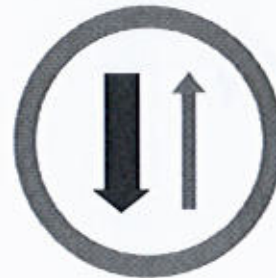

B, 5



B, 6



C, 1^a



C, 1^b



C, 2



C, 3^a



C, 3^b



C, 3^c



C, 3^d



C, 3^e



C, 3^f



C, 3^g



C, 3^h

C, 3ⁱC, 3^jC, 3^kC, 3^lC, 4^aC, 4^b

C, 5



C, 6



C, 7



C, 8



C, 9



C, 10



C, 11^a



C, 11^b



C, 12



C, 13^{aa}



C, 13^{ab}



C, 13^{ba}



C, 13^{bb}



C, 14



C, 15

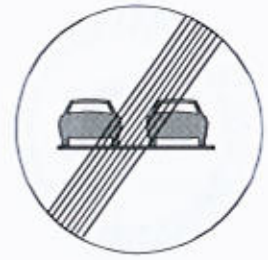

C, 16

C, 17^aC, 17^bC, 17^cC, 17^d

C, 18



C, 19

C, 20^aC, 20^b



D, 1^a



D, 1^a



D, 1^a



D, 1^a



D, 1^b



D, 2



D, 3



D, 4



D, 5



D, 6



D, 7



D, 8



D, 9



D, 10^a

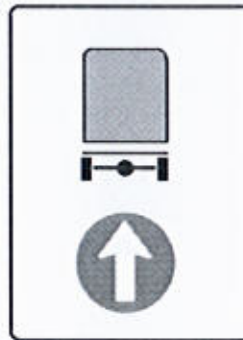

D, 10^b



D, 10^c



D, 11^a



D, 11^b



E,1^a



E,1^b

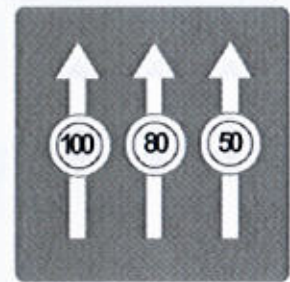

E,1^c

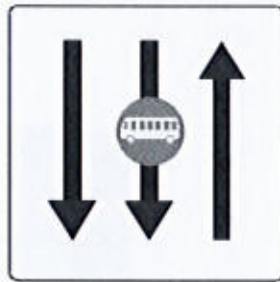

E, 2^a

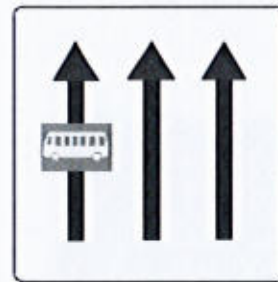

E, 2^b



E, 3^a



E, 3^b

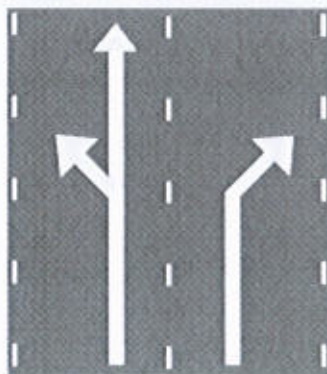

E, 4

E, 5^aE, 5^bE, 6^aE, 6^bE, 7^aE, 7^bE, 7^c



E, 7^d



E, 8^a



E, 8^b



E, 8^c



E, 8^d

E, 9^aE, 9^bE, 9^cE, 9^dE, 10^aE, 10^bE, 10^cE, 10^dE, 11^aE, 11^bE, 12^aE, 12^bE, 12^c



E, 13^a

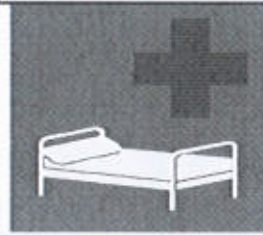

E, 13^b



E, 14^a



E, 14^b



E, 14^c



E, 15



E, 16



E, 18^a



E, 18^b



F

F, 1^aF, 1^bF, 1^c

F, 2



F, 3



F, 4



F, 5



F, 6



F, 7



F, 8



F, 9



F, 10



F, 11



F, 12



F, 13



F, 17



F, 18



G, 1^a



G, 1^b

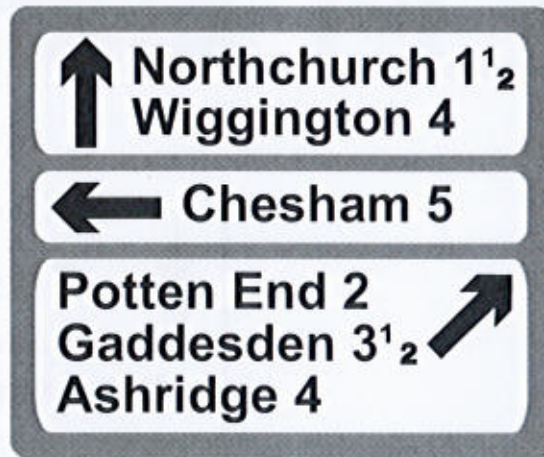

G, 1^c



G, 2^a



G, 2^b

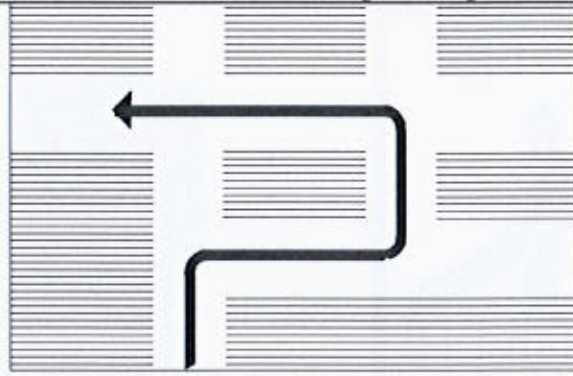

G, 3



G, 4^a



G, 4^b



G, 4^c

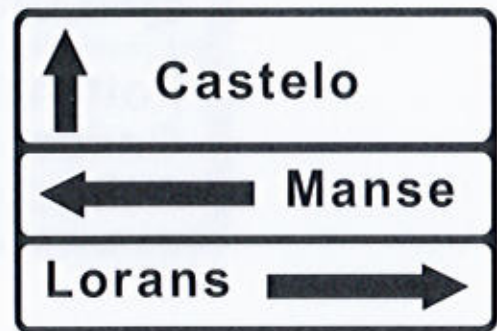

G, 5



G, 6^a



G, 6^b



G, 6^c



G, 7



G, 8



G, 9^a



G, 9^b

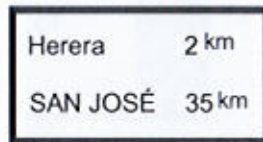

G, 10

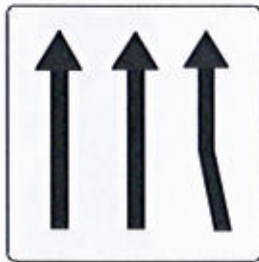

G, 11^a

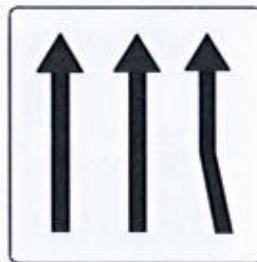

G, 11^b



G, 11^c



G, 12^a



G, 12^b



G, 13

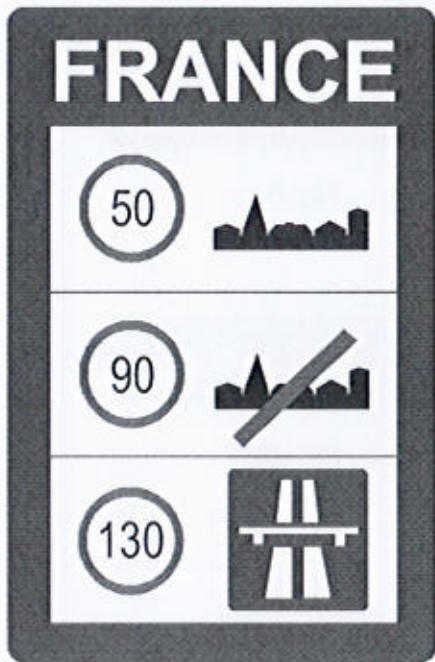

G, 14

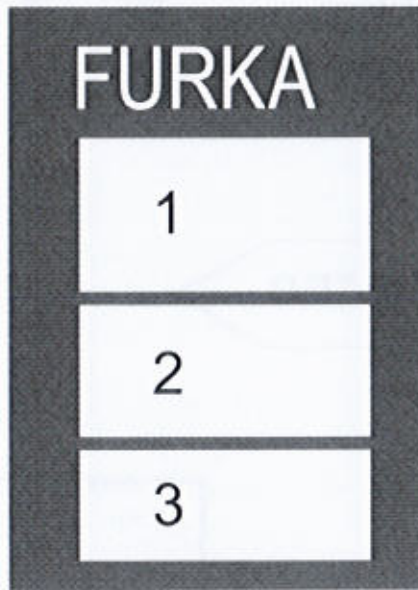

G, 15



G, 16



G, 17



G, 18



G, 19



G, 20



G, 21



G, 22^a



G, 22^b



G, 22^c



G, 23^a



G, 23^b



G, 24^a



G, 24^b



G, 24^c

A rectangular sign with a black border containing the text "200 m" in black.

H, 1

A rectangular sign with a black border containing the text "↑..... Km ↑" in black.

H, 2

H, 3^aH, 3^bH, 3^cH, 4^aH, 4^bH, 4^c



H, 5^a



H, 5^b

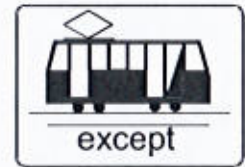

H, 6



H, 7



H, 8



H, 9

PART II

EUROPEAN AGREEMENT SUPPLEMENTING THE CONVENTION ON ROAD SIGNS AND SIGNALS OF 1968

DONE AT GENEVA ON 1 MAY 1971

*(Consolidated version**)*

** Including the amendments to the European Agreement which entered into force on 27 November 1995 (marked in the margin with a single line), and the amendments which entered into force on 28 March 2006 (marked in the margin with a double line).

EUROPEAN AGREEMENT SUPPLEMENTING THE CONVENTION ON ROAD SIGNS AND SIGNALS OPENED FOR SIGNATURE AT VIENNA ON 8 NOVEMBER 1968

THE CONTRACTING PARTIES, BEING ALSO PARTIES TO THE CONVENTION ON ROAD SIGNS AND SIGNALS OPENED FOR SIGNATURE AT VIENNA ON 8 NOVEMBER 1968,

DESIRING to achieve greater uniformity in the rules governing road signs, signals and symbols and road markings in Europe,

HAVE AGREED as follows:

Article 1

The Contracting Parties, being also Parties to the Convention on Road Signs and Signals opened for signature at Vienna on 8 November 1968, shall take appropriate measures to ensure that the system of road signs and signals and of road markings applied in their territories conforms to the provisions of the annex to this Agreement.

Article 2

1. This Agreement shall be open until 30 April 1972 for signature by States which are signatories to the Convention on Road Signs and Signals opened for signature at Vienna on 8 November 1968, or have acceded thereto, and are either members of the United Nations Economic Commission for Europe or have been admitted to the Commission in a consultative capacity in conformity with paragraph 8 of the terms of reference of the Commission.

2. This Agreement shall be subject to ratification after the State concerned has ratified the Convention on Road Signs and Signals opened for Signature at Vienna on 8 November 1968, or has acceded thereto. The instruments of ratification shall be deposited with the Secretary-General of the United Nations.

3. This Agreement shall remain open for accession by any of the States referred to in paragraph 1 of this article which are Parties to the Convention on Road Signs and Signals opened for signature at Vienna on 8 November 1968. The instruments of accession shall be deposited with the Secretary-General.

Article 3

1. Any State may, at the time of signing or ratifying this Agreement, or of acceding thereto, or at any time thereafter, declare by notification addressed to the Secretary-General that the Agreement shall become applicable to all or any of the territories for the international relations of which it is responsible. The Agreement shall become applicable to the territory or territories named in the notification thirty days after the receipt of the notification by the Secretary-General or on the date of entry into force of the Agreement for the State making the notification, whichever is the later.

2. Any State which has made a declaration under paragraph 1 of this article may at any time thereafter declare by notification addressed to the Secretary-General that the Agreement shall cease to be applicable to the territory named in the notification and the Agreement shall cease to be applicable to such territory one year from the date of receipt by the Secretary-General of the notification.

Article 4

1. This Agreement shall enter into force twelve months after the date of deposit of the tenth instrument of ratification or accession.
2. For each State ratifying, or acceding to, this Agreement after the deposit of the tenth instrument of ratification or accession, the Agreement shall enter into force twelve months after the date of deposit by such State of its instrument of ratification or accession.
3. If the date of entry into force applicable in pursuance of paragraphs 1 and 2 or this article precedes that resulting from the application of Article 39 of the Convention on Road Signs and Signals opened for signature at Vienna on 8 November 1968, this Agreement shall enter into force within the meaning of paragraph 1 of this article on the later of those two dates.

Article 5

Upon its entry into force, this Agreement shall terminate and replace, in relations between the Contracting Parties, the provisions concerning the Protocol on Road Signs and Signals contained in the European Agreement supplementing the Convention on Road Traffic and the Protocol on Road Signs and Signals of 1949, signed at Geneva on 16 September 1950, the Agreement on Signs for Road Works signed at Geneva on 16 December 1955, and the European Agreement on Road Markings signed at Geneva on 13 December 1957.

Article 6

1. After this Agreement has been in force for twelve months, any Contracting Party may propose one or more amendments to the Agreement. The text of any proposed amendment, accompanied by an explanatory memorandum, shall be transmitted to the Secretary-General, who shall communicate it to all Contracting Parties. The Contracting Parties shall have the opportunity of informing him within a period of twelve months following the date of its circulation whether they: (a) accept the amendment; or (b) reject the amendment; or (c) wish that a conference be convened to consider the amendment. The Secretary-General shall also transmit the text of the proposed amendment to the other States referred to in article 2 of this Agreement.

2. (a) Any proposed amendment communicated in accordance with paragraph 1 of this article shall be deemed to be accepted if within the period of twelve months referred to in the preceding paragraph less than one-third of the Contracting Parties inform the Secretary-General that they either reject the amendment or wish that a conference be convened to consider it. The Secretary-General shall notify all Contracting Parties of each acceptance or rejection of any proposed amendment and of requests that a conference be convened. If the total number of such rejections and requests received during the specified period of twelve months is less than one-third of the total number of Contracting Parties, the Secretary-General shall notify all Contracting Parties, that the amendment will enter into force six months after the expiry of the period of twelve months referred to in paragraph 1 of this article for all Contracting Parties except those which, during the period specified, have rejected the amendment or requested the convening of a conference to consider it.

(b) Any Contracting Party which, during the said period of twelve months, has rejected a proposed amendment or requested the convening of a conference to consider it may at any time after the end of such period notify the Secretary-General that it accepts the amendment, and the Secretary-General shall communicate such notification to all other Contracting Parties. The amendment shall enter into force, with respect to the Contracting Party which has notified its acceptance, six months after the date on which the Secretary-General received the notification.

3. If a proposed amendment has not been accepted in accordance with paragraph 2 of this article and if within the period of twelve months specified in paragraph 1 of this article less than half of the total number of the Contracting Parties inform the Secretary-General that they reject the proposed amendment and if at least one-third of the total number of Contracting Parties, but not less than five, inform him that they accept it or wish a conference to be convened to consider it, the Secretary-General shall convene a conference for the purpose of considering the proposed amendment or any other proposal which may be submitted to him in accordance with paragraph 4 of this article.

4. If a conference is convened in accordance with paragraph 3 of this article, the Secretary-General shall invite to it all the Contracting Parties and the other States referred to in article 2 of this Agreement. He shall request all States invited to the Conference to submit to him, at least six months before its opening date, any proposals which they may wish the Conference to consider in addition to the proposed amendment and shall communicate such proposals, at least three months before the opening date of the conference, to all States invited to the Conference.

5. (a) Any amendment to this Agreement shall be deemed to be accepted if it has been adopted by a two-thirds majority of the States represented at the Conference, provided that such majority comprises at least two-thirds of the Contracting Parties represented at the Conference. The Secretary-General shall notify all Contracting Parties of the adoption of the amendment, and the amendment shall enter into force twelve months after the date of this notification for all Contracting Parties except those which during that period have notified the Secretary-General that they reject the amendment.

(b) A Contracting Party which has rejected an amendment during the said period of twelve months may at any time notify the Secretary-General that it accepts the amendment, and the Secretary-General shall communicate such notification to all the other Contracting Parties. The amendment shall enter into force, with respect to the Contracting Party which has notified its acceptance, six months after receipt by the Secretary-General of the notification or at the end of the said period of twelve months, whichever is later.

6. If the proposed amendment is not deemed to be accepted pursuant to paragraph 2 of this article and if the conditions prescribed by paragraph 3 of this article for convening a conference are not fulfilled, the proposed amendment shall be deemed to be rejected.

7. Independently of the amendment procedure prescribed in paragraphs 1-6 of this article, the annex to this Agreement may be amended by agreement between the competent administrations of all Contracting Parties. If the administration of a Contracting Party states that its national law obliges it to subordinate its agreement to the grant of a specific authorization or to the approval of a legislative body, the competent administration of the Contracting Party in question shall be considered to have consented to the amendment to the annex only at such time as it notifies the Secretary-General that it has obtained the required authorization or approval. The agreement between the competent administrations may provide that, during a transitional period, the former provisions of the annex shall remain in force, in whole or in part, simultaneously with the new provisions. The Secretary-General shall appoint the date of entry into force of the new provisions.

8. Each State shall, at the time of signing, ratifying, or acceding to, this Agreement, inform the Secretary-General of the name and address of its administration competent in the matter of agreement as contemplated in paragraph 7 of this article.

Article 7

Any Contracting Party may denounce this Agreement by written notification addressed to the Secretary-General. The denunciation shall take effect one year after the date of receipt by the

Secretary-General of such notification. Any Contracting Party which ceases to be a Party to the Convention on Road Signs and Signals opened for signature at Vienna on 8 November 1968 shall on the same date cease to be a Party to this Agreement.

Article 8

This Agreement shall cease to be in force if the number of Contracting Parties is less than five for any period of twelve consecutive months, or at such time as the Convention on Road Signs and Signals opened for signature at Vienna on 8 November 1968 ceases to be in force.

Article 9

1. Any dispute between two or more Contracting Parties which relates to the interpretation or application of this Agreement and which the Parties in dispute are unable to settle by negotiation or other means of settlement shall be referred to arbitration if any of the Contracting Parties in dispute so requests, and shall, to that end, be submitted to one or more arbitrators selected by mutual agreement between the Parties in dispute. If the Parties in dispute fail to agree on the choice of an arbitrator or arbitrators within three months after the request for arbitration, any of those Parties may request the Secretary-General of the United Nations to appoint a single arbitrator to whom the dispute shall be submitted for decision.

2. The award of the arbitrator or arbitrators appointed in accordance with paragraph 1 of this article shall be binding upon the Contracting Parties in dispute.

Article 10

Nothing in this Agreement shall be construed as preventing a Contracting Party from taking such action, compatible with the provisions of the Charter of the United Nations and limited to the exigencies of the situation, as it considers necessary to its external or internal security.

Article 11

1. Any State may, at the time of signing this Agreement or of depositing its instrument of ratification or accession, declare that it does not consider itself bound by article 9 of this Agreement. Other Contracting Parties shall not be bound by article 9 with respect to any Contracting Party which has made such a declaration.

2. Reservations to this Agreement, other than the reservation provided for in paragraph 1 of this article, shall be permitted on condition that they are formulated in writing and, if formulated before the deposit of the instrument of ratification or accession, are confirmed in that instrument.

3. Any State shall, at the time of depositing its instrument of ratification of this Agreement or of accession thereto, notify the Secretary-General in writing to what extent any reservation made by it to the Convention on Road Signs and Signals opened for signature at Vienna on 8 November 1968 apply to this Agreement. Any reservations to the Convention on Road Signs and Signals which have not been included in the notification made at the time of depositing the instrument of ratification of this Agreement or of accession thereto shall be deemed to be inapplicable to this Agreement.

4. The Secretary-General shall communicate the reservations and notifications made pursuant to this article to all States referred to in article 2 of this Agreement.

5. Any State which has made a declaration, a reservation or a notification under this article may withdraw it at any time by notification addressed to the Secretary-General.

6. Any reservation made in accordance with paragraph 2 or notified in accordance with paragraph 3 of this article,

(a) modifies, for the Contracting Party which has made or notified the reservation, the provisions of the Agreement to which the reservation relates, to the extent of the reservation;

(b) modifies those provisions to the same extent for the other Contracting Parties in their relations with the Contracting Party which made or notified the reservation.

Article 12

In addition to the declarations, notifications and communications provided for in articles 6 and 11 of this Agreement, the Secretary-General shall notify the Contracting Parties and the other States referred to in article 2 of the following:

(a) signatures, ratifications and accessions under article 2;

(b) notifications and declarations under article 3;

(c) the dates of entry into force of this Agreement in accordance with article 4;

(d) the date of entry into force of amendments to this Agreement in accordance with article 6, paragraphs 2, 5 and 7;

(e) denunciations under article 7;

(f) the termination of this Agreement under article 8.

Article 13

After 30 April 1972, the original of this Agreement shall be deposited with the Secretary-General of the United Nations, who shall send certified true copies to all the States referred to in article 2 of this Agreement.

IN WITNESS WHEREOF, the undersigned, being duly authorized thereto, have signed this Agreement.

DONE at Geneva, this first day of May nineteen hundred and seventy one, in a single copy in the English, French and Russian languages, the three texts being equally authentic.

ANNEX (of the European Agreement)

1. For the purpose of this annex, the term "Convention" means the Convention on Road Signs and Signals opened for signature at Vienna on 8 November 1968.

2. This annex contains only the additions to, and modifications of the corresponding provisions of the Convention.

3. Ad Article 1 of the Convention (Definitions)

Subparagraph (b)

This subparagraph shall be read as follows:

"'Built-up area' means an area with entries and exits specially signposted as such;"

Additional subparagraph to be inserted immediately after subparagraph (b) of this article

This subparagraph shall be read as follows:

"'Residential area' means a specially-designed area where special traffic rules apply and which is signposted as such at its entries and exits."

Subparagraph (1)

Three-wheeled vehicles whose unladen mass does not exceed 400 kg shall be treated as motor cycles.

Additional subparagraph to be inserted at the end of this article

This subparagraph shall be read as follows:

"Persons pushing or pulling a child's carriage, a bath chair or invalid chair, or any other small vehicle without an engine, or pulling a cycle or moped and handicapped persons travelling in invalid chairs propelled by such persons or moving at walking pace shall be treated as pedestrians."

4. Ad Article 3 of the Convention (Obligations of the Contracting Parties)

Paragraph 3

This paragraph shall be read as follows:

"Any sign, symbol, installation or marking which does not conform to the system prescribed in the Convention and in this Agreement shall be replaced within ten years from the date of entry into force of this Agreement. During this period, in order to familiarize road-users with the system prescribed in the Convention and in this Agreement, previous signs, symbols and inscriptions may be retained beside those prescribed in the Convention and in this Agreement."

5. Ad Article 6 of the Convention

Paragraph 4

The provisions of this paragraph, which are recommendations in the Convention, shall be obligatory.

6. Ad Article 7 of the ConventionParagraph 1Additional sentence to be inserted at the end of this paragraph

This sentence shall be read as follows:

“In addition, in the case of such signs it is recommended that signs lighted or equipped with reflecting material or reflecting devices and signs not so lighted or equipped should not be used on the same section of road.”

7. Ad article 8 of the ConventionParagraph 3

This paragraph shall be read as follows:

“During the transitional period of ten years prescribed in item 4 of this annex, and thereafter in exceptional circumstances to facilitate the interpretation of signs, an inscription may be added in a rectangular panel below the sign or in a rectangular panel containing the sign; such an inscription may also be placed on the sign itself, if this does not make the sign more difficult to understand for drivers who cannot understand the inscription.”

8. Ad Article 9 of the ConventionParagraph 1

Each State shall select A^a as the model for danger warning signs.

9. Ad Article 10 of the Convention (Priority Signs)Paragraph 3

Each State shall select B, 2^a as the model for the “STOP” sign.

Paragraph 6

To give advance warning of sign B, 1, the same sign supplemented by additional panel H, 1 described in Annex 1, section H to the Convention shall be used.

To give advance warning of sign B, 2^a, sign B, 1, supplemented by a rectangular panel bearing the “STOP” symbol and a figure indicating the distance to the sign B, 2^a, shall be used.

9 bis Ad Article 13 bis of the Convention (Special regulation signs)Paragraph 2

This paragraph shall be read as follows:

“Signs E, 7^a; E, 7^b or E, 7^c and E, 8^a; E, 8^b or E, 8^c shall notify road-users that the general regulations governing traffic in built-up areas in the territory of the State apply from signs E, 7^a; E, 7^b or E, 7^c to signs E, 8^a; E, 8^b or E, 8^c except insofar as different regulations may be notified by other signs on certain sections of road in the built-up area. They shall bear inscriptions in a dark colour on a white or light-coloured ground and shall be placed respectively at the entries and exits of a built-up area. However, sign B, 4 shall always be placed on a priority road marked with sign B, 3 if that road ceases to have priority where it passes through the built-up area.”

10. Ad Article 18 of the Convention (Place identification signs)

Place identification signs shall bear inscriptions in white or light colour on a dark-coloured ground.

11. Ad Article 23 of the Convention (Signals for vehicular traffic)

[*paragraphs deleted*]

Additional paragraph to be inserted immediately after paragraph 11 of this article

This paragraph shall be read as follows:

“In special cases where it is not necessary to use light signals continuously, a signal in the form of a non-flashing amber light followed by a non-flashing red light may be used; the non-flashing amber light may be preceded by a flashing amber light.”

12. Ad Article 24 of the Convention (Signals for pedestrians only)

Paragraph 1, subparagraph (a) (ii)

This provision shall not be applied.

Paragraph 2

This paragraph shall be read as follows:

“Light signals for pedestrians shall be of the two-colour system, comprising two lights, red and green respectively. Two lights shall never be shown simultaneously.”

Paragraph 3

This paragraph shall be read as follows:

“The lights shall be arranged vertically, with the red light always at the top and the green light always at the bottom. The red light shall be in the form of a standing pedestrian or of standing pedestrians and the green light in the form of a walking pedestrian or of walking pedestrians.”

13. Ad Article 31 of the Convention (Signs for road works)

Paragraph 2

The barriers shall not be painted with alternate black and white or black and yellow stripes.

14. Ad Article 32 of the Convention (Marking by lights or reflecting devices)

This article shall be read as follows:

“1. It is recommended that attention should be drawn to the presence of bollards or islands on the carriageway by means of white or yellow lights or white or yellow reflecting devices.

2. If the edges of the carriageway are marked by means of lights or reflecting devices, the lights or reflecting devices shall be either:

(a) all white or light yellow; or

(b) white or light yellow to mark the edge of the carriageway opposite to the direction of traffic, and red or dark yellow to mark the edge of the carriageway appropriate to the direction of traffic.

(c) Each State Party to this Agreement shall adopt for the whole of its territory the same colour or the same system of colours for the lights or reflecting devices referred to in this article”.

15. Ad Article 33 of the Convention

Paragraph 1, subparagraph (a)

This subparagraph shall be read as follows:

“Where a signalling system is installed at a level-crossing to give warning of the approach of trains or of the imminent closing of the gates (barriers) or half-gates (half-barriers), it shall consist of a red flashing light or of red lights flashing alternately, as specified in article 23, paragraph 1 (b), of the Convention. At level-crossings which have neither gates (barriers) nor half-gates (half-barriers), the signalling system shall preferably consist of two red lights flashing alternately. However:

- (i) Flashing red lights may be supplemented or replaced by light signals of the three-colour red-amber-green system described in article 23, paragraph 2, of the Convention, or by such a signal without the green light if other three-colour light signals are installed on the road near the level-crossing or if the crossing is equipped with gates (barriers). Flashing red lights at level-crossings having half-gates (half-barriers) may not be replaced in the manner specified in the preceding sentence; they may however be supplemented in that manner on condition that other three-colour light signals are installed on the road near the level-crossing;
- (ii) On earth-tracks (dirt roads) where traffic is very light, and on footpaths, only a sound signal need be used.”

Paragraph 2

This paragraph shall be read as follows:

“The light signals shall be installed on the edge of the carriageway appropriate to the direction of traffic; whenever conditions such as the visibility of the signals or the density of traffic so require, the lights shall be repeated on the other side of the road. However, if it is considered preferable because of local conditions, the lights may be repeated above the carriageway or on an island in the carriageway.”

16. Ad Article 35 of the Convention

Paragraph 1

The gates (barriers) and half-gates (half-barriers) of level-crossings shall not be marked in alternate stripes of black and white or black and yellow.

17. Ad Annex 1, section A, subsection II, to the Convention

Paragraph 2 (Dangerous descent)

This paragraph shall be read as follows:

- “(a) To give warning of a steep descent, symbol A, 2^a shall be used.

(b) The left-hand part of symbol A, 2^a shall occupy the left-hand corner of the sign panel and its base shall extend over the whole width of the panel; the figure shows the gradient as a percentage.”

Paragraph 3 (Steep ascent)

This paragraph shall be read as follows:

“(a) To give warning of a steep ascent, symbol A, 3^a shall be used.

(b) The right-hand part of symbol A, 3^a shall occupy the right-hand corner of the sign panel and its base shall extend over the whole width of the panel; the figure shows the gradient as a percentage.”

Paragraph 12 (Pedestrian crossing)

This paragraph shall be read as follows:

“(a) Warning of a pedestrian crossing shall be given by symbol A, 12^a.

(b) The symbol may be reversed.”

Paragraph 18 (Intersection where the priority is prescribed by the general priority rule)

This paragraph shall be read as follows:

“Warning of an intersection where the priority is that prescribed by the general priority rule in force in the country shall be given by symbol A, 18^a.”

Paragraph 20 (Intersection with a road to whose users drivers must give way)

This paragraph shall be read as follows:

“Sign B, 1 or sign B, 2^a shall be used in conformity with the provisions of item 9 of this annex.”

Paragraph 22 (Intersection where traffic is regulated by a light signal)

This paragraph shall be read as follows:

“If traffic at the intersection is regulated by a light signal, a sign A^a, bearing the symbol A, 17 described in paragraph 17 above, may be set up to supplement or replace the signs described in paragraphs 18 to 21 above.”

Paragraph 26 (Other level crossings)

Subparagraph (b)

This subparagraph shall be read as follows:

“Warning of other level-crossings shall be given by symbol A, 26^a or by symbol A, 27 as appropriate.”

Paragraph 28 (Signs to be placed in the immediate vicinity of level-crossings)

Model A, 28^e of sign A, 28 shall not be used.

Models A, 28^a and A, 28^b may show red stripes on condition that neither the general appearance nor the effectiveness of the signs is impaired thereby.

18. Ad annex 1, section B, to the Convention

Paragraph 1 ("GIVE WAY" sign)

Sign B, 1 shall bear neither symbol nor inscription.

Paragraph 2 ("STOP" sign)

This paragraph shall be read as follows:

"The "STOP" sign shall be sign B, 2, model B, 2^a. Sign B, 2, model B, 2^a shall be octagonal with a red ground, surrounded by a narrow white or light yellow border and bear the symbol "STOP" in white or light yellow; the height of the symbol shall be not less than one third of the height of the panel. The height of the normal-sized sign B, 2^a shall be approximately 0.90 m; the height of the small signs shall be not less than 0.60 m."

19. Ad Annex 1, section C, subsection II, to the Convention

Paragraph 1 (Prohibition and restriction of entry)

Model C, 1^b of sign C, 1 shall not be used.

The two signs C, 3^m and C, 3^a reproduced in the appendix to this annex and having the following meaning may be used:

C, 3^m "NO ENTRY FOR VEHICLES CARRYING MORE THAN A CERTAIN QUANTITY OF EXPLOSIVES OR READILY INFLAMMABLE SUBSTANCES"

C, 3^a "NO ENTRY FOR VEHICLES CARRYING MORE THAN A CERTAIN QUANTITY OF SUBSTANCES LIABLE TO CAUSE WATER POLLUTION".

The note at the end of subparagraph (c) shall be read as follows:

"Signs C, 3^a to C, 3^l as well as signs C, 3^m and C, 3^a mentioned under this item shall not incorporate an oblique red bar."

Paragraph 4 (Prohibition of overtaking)

Models C, 13^{ab} and C, 13^{bb} of the signs C, 13^a and C, 13^b shall not be used.

Paragraph 9, subparagraph (a) (ii)

This provision shall not be applied.

Paragraph 9, subparagraph (b) (iii)

This provision shall not be applied.

Paragraph 9, subparagraph (c) (v)

The possibility, where the prohibition applies only over a short distance, of setting up only one sign showing in a red circle the distance on which the prohibition applies, shall not be used.

20. Ad Annex 1, section D, subsection I, to the Convention

Paragraph 2

This paragraph shall be read as follows:

“Unless provided otherwise, the signs shall be blue and the symbols shall be white or of a light colour.”

21. Ad Annex 1, section D, subsection II, to the Convention

Paragraph 1 (Direction to be followed)

Sign D, 1^b shall not be used.

Paragraph 3 (Compulsory roundabout)

[Deleted]

22. Ad Annex 1, section E, subsection II, to the Convention

Paragraph 3 (“ONE-WAY” sign), subparagraph (a) (ii)

The arrow of sign E, 3^b shall bear an inscription only if the effectiveness of the sign is not impaired thereby.

Paragraph 5 (Signs notifying an entry to or an exit from a motorway)

Additional subparagraph, to be inserted immediately after subparagraph (a) of this paragraph

This subparagraph shall be read as follows:

“Sign E, 5^a may be used, and repeated, to give warning of the approach of a motorway. Each sign set up for this purpose shall carry either an inscription in its lower part showing the distance between the sign and the beginning of the motorway or an additional panel H, 1 described in Annex 1, section H to the Convention.”

Paragraph 6 (Signs notifying an entry to or an exit from a road on which the traffic rules are the same as on a motorway)

Additional subparagraph to be inserted immediately after subparagraph (a) of this paragraph

This subparagraph shall be read as follows:

“Sign E, 6^a may be used and repeated to give warning of the approach to a road on which the traffic rules are the same as on a motorway. Each sign set up for this purpose shall carry either an inscription in its lower part showing the distance between the sign and the beginning of the road on which the traffic rules are the same as on a motorway or an additional panel H, 1 described in Annex 1, section H to the Convention.”

Paragraph 7 (Signs indicating the beginning and the end of a built-up area)

This paragraph shall be read as follows:

“(a) The sign to indicate the beginning of a built-up area shall bear the name of the built-up area or the symbol showing the silhouette of a built-up area or the two combined.

The inscriptions shall be in a dark colour on a white or light-coloured ground and the sign shall have a dark-coloured border.

Signs E, 7^a, E, 7^b and E, 7^c are examples of signs showing the beginning of a built-up area.

(b) The sign showing the end of a built-up area shall be identical except that it shall be crossed by an oblique bar coloured red or consisting of parallel lines coloured red running from the upper right edge to the lower left edge.

Signs E, 8^a, E, 8^b and E, 8^c are examples of signs indicating the end of a built-up area.

Notwithstanding the provisions of article 6, paragraph 1 of this Convention these signs may be placed on the reverse side of signs identifying a built-up area.

(c) The signs covered by this section shall be used in conformity with the provisions of the Convention, article 13 bis, paragraph 2."

Paragraph 10 (Pedestrian crossing)

Sign E, 12^b shall not be used.

Paragraph 12 ("PARKING" sign)

The square panel mentioned in the first subparagraph of this paragraph shall bear the letter "P".

Additional paragraph to be inserted immediately after paragraph 13

This paragraph shall be read as follows:

"Signs notifying an entry to or an exit from a residential area where special traffic rules apply

Sign E, 17^a "RESIDENTIAL AREA" shall be placed at the point where the special rules to be observed in a residential area referred to in article 27 bis of the Convention on Road Traffic supplemented by the European Agreement begin to apply. Sign E, 17^b "END OF RESIDENTIAL AREA" shall be placed at the point where those rules cease to apply."

23. Ad Annex 1, section F, subsection II to the Convention

Paragraph 1 ("FIRST-AID STATION" symbol)

Symbols F, 1^b and F, 1^c shall not be used.

Paragraph 2 (Miscellaneous symbols)

Additional text to be inserted at the end of this paragraph

F, 14 "RADIO STATIONS GIVING TRAFFIC INFORMATION"

Inscription on white square: Under the word "radio" there might be an indication of the name or the code of the radio station when necessary in abridged form and the number of the programme. The word "Radio" may be repeated also in the national language.

Inscription on blue ground: Indication of the frequency and, if necessary, the wavelength of the local radio station.

It is left to the discretion of the countries to add in the case of VHF stations the indication "MHz" or the regional code, and in the case of medium-frequency or long-frequency stations the indication "kc/s"

The wavelength may be given in figures with the letter m (e.g. 1500m).

F, 15 PUBLIC LAVATORY
F, 16 BEACH OR SWIMMING POOL

24. Ad Annex 1, section G, subsection II, to the Convention

Paragraph 2 (Special cases), subparagraph (a)

The red bar of signs G, 2^a and G, 2^b shall be surrounded by a white rim.

25. Ad Annex 1, section G, subsection III, to the Convention

Paragraph 1

Sign G, 4^c shall not be used.

Paragraph 2

Sign G, 6^c shall not be used.

26. Ad Annex 1, section G, subsection V, to the Convention

Paragraph 3 ("NO THROUGH ROAD" sign)

The red bar of sign G, 13 shall be surrounded by a white rim.

27. Ad Annex 1, section H, to the Convention

Additional paragraph to be inserted immediately after paragraph 1

This paragraph shall be read as follows:

"The ground of additional panels should be preferably the same as the ground of the particular groups of signs with which they are used."

Appendix to Annex to the European Agreement

Replace the words "Additional sign No.1" and "Additional sign No.2" by: "C, 3^{en}" and "C,3^{an}" respectively.

Insert new signs: E, 17^a; E, 17^b; F, 14; F, 15 and F, 16, which are reproduced at the end of this document.

ANNEX - APPENDIX



C, 3^m



C, 3ⁿ



E, 17^a



E, 17^b



F, 14



F, 15



F, 16

PART III

PROTOCOL ON ROAD MARKINGS, ADDITIONAL TO THE EUROPEAN AGREEMENT SUPPLEMENTING THE CONVENTION ON ROAD SIGNS AND SIGNALS OF 1968

DONE AT GENEVA ON 1 MARCH 1973

*(Consolidated version^{***})*

^{***} Including the amendments to the Protocol on Road Markings, which entered into force on 28 March 2006 (marked in the margin with a double line).

PROTOCOL ON ROAD MARKINGS, ADDITIONAL TO THE EUROPEAN AGREEMENT SUPPLEMENTING THE CONVENTION ON ROAD SIGNS AND SIGNALS OPENED FOR SIGNATURE AT VIENNA ON 8 NOVEMBER 1968

THE CONTRACTING PARTIES, BEING ALSO PARTIES TO THE CONVENTION ON ROAD SIGNS AND SIGNALS OPENED FOR SIGNATURE AT VIENNA ON 8 NOVEMBER 1968 AND TO THE EUROPEAN AGREEMENT SUPPLEMENTING THAT CONVENTION AND OPENED FOR SIGNATURE AT GENEVA ON 1 MAY 1971,

DESIRING to achieve greater uniformity in Europe in the rules governing road markings,

HAVE AGREED as follows:

Article 1

The Contracting Parties, being also Parties to the Convention on Road Signs and Signals opened for signature at Vienna on 8 November 1968 and to the European Agreement supplementing that Convention and opened for signature at Geneva on 1 May 1971, shall take appropriate measures to ensure that the system of road markings applied in their territories conforms to the provision of the annex to this Protocol.

Article 2

1. This Protocol shall be open until 1 March 1974 for signature by States which are signatories to, or have acceded to, the Convention on Road Signs and Signals opened for signature at Vienna on 8 November 1968 and to the European Agreement supplementing that Convention and opened for signature at Geneva on 1 May 1971, and are either members of the United Nations Economic Commission for Europe or have been admitted to the Commission in a consultative capacity in conformity with paragraph 8 of the terms of reference of the Commission.

2. This Protocol shall be subject to ratification after the State concerned has ratified, or acceded to, the Convention on Road Signs and Signals opened for signature at Vienna on 8 November 1968 and the European Agreement supplementing that Convention and opened for signature at Geneva on 1 May 1971. The instruments of ratification shall be deposited with the Secretary-General of the United Nations.

3. This Protocol shall remain open for accession by any of the States referred to in paragraph 1 of this article which are Parties to the Convention on Road Signs and Signals opened for signature at Vienna on 8 November 1968 and to the European Agreement supplementing that Convention and opened for signature on 1 May 1971. The instruments of accession shall be deposited with the Secretary-General.

Article 3

1. Any State may, at the time of signing or ratifying this Protocol, or of acceding thereto, or at any time thereafter, declare by notification addressed to the Secretary-General that the Protocol shall become applicable to all or any of the territories for the international relations of which it is responsible. The Protocol shall become applicable to the territory or territories named in the notification thirty days after the receipt of the notification by the Secretary-General or on the date of entry into force of the Protocol for the State making the notification, whichever is the later.

2. Any State which has made a declaration under paragraph 1 of this article may at any time thereafter declare by notification addressed to the Secretary-General that the Protocol shall cease to be applicable to the territory named in the notification, and the Protocol shall cease to be applicable to such territory one year from the date of receipt by the Secretary-General of the notification.

Article 4

1. This Protocol shall enter into force twelve months after the date of deposit of the tenth instrument of ratification or accession.

2. For each State ratifying, or acceding to, this Protocol after the deposit of the tenth instrument of ratification or accession, the Protocol shall enter into force twelve months after the date of deposit by such State of its instrument of ratification or accession.

3. If the date of entry into force applicable in pursuance of paragraphs 1 and 2 of this article precedes that resulting from the application of Article 39 of the Convention on Road Signs and Signals opened for signature at Vienna on 8 November 1968, this Protocol shall enter into force within the meaning of paragraph 1 of this article on the later of those two dates.

Article 5

Upon its entry into force, this Protocol shall terminate and replace, in relations between the Contracting Parties, the provisions concerning the Protocol on Road Signs and Signals contained in the European Agreement supplementing the Convention on Road Traffic and the Protocol on Road Signs and Signals of 1949 signed at Geneva on 16 September 1950, the Agreement on Signs for Road Works signed at Geneva on 16 December 1955, and the European Agreement on Road Markings signed at Geneva on 13 December 1957.

Article 6

1. After this Protocol has been in force for twelve months, any Contracting Party may propose one or more amendments to the Protocol. The text of any proposed amendment, accompanied by an explanatory memorandum, shall be transmitted to the Secretary-General, who shall communicate it to all Contracting Parties. The Contracting Parties shall have the opportunity of informing him within a period of twelve months following the date of its circulation whether they: (a) accept the amendment; or (b) reject the amendment; or (c) wish that a conference be convened to consider the amendment. The Secretary-General shall also transmit the text of the proposed amendment to the other States referred to in article 2 of this Protocol.

2. (a) Any proposed amendment communicated in accordance with paragraph 1 of this article shall be deemed to be accepted if within the period of twelve months referred to in the preceding paragraph less than one-third of the Contracting Parties inform the Secretary-General that they either reject the amendment or wish that a conference be convened to consider it. The Secretary-General shall notify all Contracting Parties of each acceptance or rejection of any proposed amendment and of requests that a conference be convened. If the total number of such rejections and requests received during the specified period of twelve months is less than one-third of the total number of Contracting Parties, the Secretary-General shall notify all Contracting Parties that the amendment will enter into force six months after the expiry of the period of twelve months referred to in paragraph 1 of this article for all Contracting Parties except those which, during the period specified, have rejected the amendment or requested the convening of a conference to consider it.

(b) Any Contracting Party which, during the said period of twelve months, has rejected a proposed amendment or requested the convening of a conference to consider it may at

any time after the end of such period notify the Secretary-General that it accepts the amendment, and the Secretary-General shall communicate such notification to all the other Contracting Parties. The amendment shall enter into force, with respect to the Contracting Party which has notified its acceptance, six months after the date on which the Secretary-General receives the notification.

3. If a proposed amendment has not been accepted in accordance with paragraph 2 of this article and if within the period of twelve months specified in paragraph 1 of this article less than half of the total number of the Contracting Parties inform the Secretary-General that they reject the proposed amendment and if at least one-third of the total number of Contracting parties, but not less than five, inform him that they accept it or wish a conference to be convened to consider it, the Secretary-General shall convene a conference for the purpose of considering the proposed amendment or any other proposal which may be submitted to him in accordance with paragraph 4 of this article.

4. If a conference is convened in accordance with paragraph 3 of this article, the Secretary-General shall invite to it all the Contracting Parties and the other States referred to in article 2 of this Protocol. He shall request all States invited to the conference to submit to him, at least six months before its opening date, any proposals which they may wish the conference to consider in addition to the proposed amendment and shall communicate such proposals, at least three months before the opening date of the conference, to all States invited to the conference.

5. (a) Any amendment to this Protocol shall be deemed to be accepted if it has been adopted by a two-thirds majority of the States represented at the conference, provided that such majority comprises at least two-thirds of the Contracting Parties represented at the conference. The Secretary-General shall notify all Contracting Parties of the adoption of the amendment, and the amendment shall enter into force twelve months after the date of this notification for all Contracting Parties except those which during that period have notified the Secretary-General that they reject the amendment.

(b) A Contracting Party which has rejected an amendment during the said period of twelve months may at any time notify the Secretary-General that it accepts the amendment, and the Secretary-General shall communicate such notification to all the other Contracting parties. The amendment shall enter into force, with respect to the Contracting Party which has notified its acceptance, six months after receipt by the Secretary-General of the notification or at the end of the said period of twelve months, whichever is later.

6. If the proposed amendment is, not deemed to be accepted pursuant to paragraph 2 of this article and if the conditions prescribed by paragraph 3 of this article for convening a conference are not fulfilled, the proposed amendment shall be deemed to be rejected.

7. Independently of the amendment procedure prescribed in paragraphs 1-6 of this article, the annex to this Protocol may be amended by agreement between the competent administrations of all Contracting Parties. If the administration of a Contracting Party states that its national law obliges it to subordinate its agreement to the grant of a specific authorization or to the approval of a legislative body, the competent administration of the Contracting Party in question shall be considered to have consented to the amendment to the annex only at such time as it notifies the Secretary-General that it has obtained the required authorization or approval. The Agreement between the competent administrations may provide that, during a transitional period, the former provisions of the annex shall remain in force, in whole or in part, simultaneously with the new provisions. The Secretary-General shall appoint the date of entry into force of the new provisions.

8. Each State shall, at the time of signing, ratifying, or acceding to this Protocol, inform the Secretary-General of the name and address of its administration competent in the matter of agreement as contemplated in paragraph 7 of this article.

Article 7

Any Contracting Party may denounce this Protocol by written notification addressed to the Secretary-General. The denunciation shall take effect one year after the date of receipt by the Secretary-General of such notification. Any Contracting Party which ceases to be a Party to the Convention on Road Signs and Signals opened for signature at Vienna on 8 November 1968 and to the European Agreement supplementing that Convention and opened for signature at Geneva on 1 May 1971, shall on the same date cease to be a party to this Protocol.

Article 8

This Protocol shall cease to be in force if the number of Contracting Parties is less than five for any period of twelve consecutive months, or at such time as the Convention on Road Signs and Signals opened for signature at Vienna on 8 November 1968, or the European Agreement supplementing that Convention and opened for Signature at Geneva on 1 May 1971, ceases to be in force.

Article 9

1. Any dispute between two or more Contracting Parties which relates to the interpretation or application of this Protocol and which the Parties in dispute are unable to settle by negotiation or other means of settlement shall be referred to arbitration if any of the Contracting Parties in dispute so requests, and shall, to that end, be submitted to one or more arbitrators selected by mutual agreement between the Parties in dispute. If the parties in dispute fail to agree on the choice of an arbitrator or arbitrators within three months after the request for arbitration, any of those Parties may request the Secretary-General of the United Nations to appoint a single arbitrator to whom the dispute shall be submitted for decision.
2. The award of the arbitrator or arbitrators appointed in accordance with paragraph 1 of this article shall be binding upon the Contracting Parties in dispute.

Article 10

Nothing in this Protocol shall be construed as preventing a Contracting Party from taking such action, compatible with the provisions of the Charter of the United Nations and limited to the exigencies of the situation, as it considers necessary to its external or internal security.

Article 11

1. Any State may, at the time of signing this Protocol or of depositing its instrument of ratification or accession, declare that it does not consider itself bound by article 9 of this Protocol. Other Contracting Parties shall not be bound by article 9 with respect to any Contracting Party which has made such a declaration.
2. Reservations to this Protocol, other than the reservation provided for in paragraph 1 of this article, shall be permitted on condition that they are formulated in writing and, if formulated before the deposit of the instrument of ratification or accession, are confirmed in that instrument.
3. Any State shall, at the time of depositing its instrument of ratification of this Protocol or of accession thereto, notify the Secretary-General in writing to what extent any reservation made by it to the Convention on Road Signs and Signals opened for signature at Vienna on 8 November 1968, or to the European Agreement supplementing that Convention and opened for signature at Geneva on 1 May 1971, apply to this Protocol. Any reservations to the Convention on Road Signs and Signals which have not been included in the notification made at the time of depositing the

instrument of ratification of this Protocol or of accession thereto shall be deemed to be inapplicable to this Protocol.

4. The Secretary-General shall communicate the reservations and notifications made pursuant to this article to all States referred to in article 2 of this Protocol.

5. Any State which has made a declaration, a reservation or a notification under this article may withdraw it at any time by notification addressed to the Secretary-General.

6. Any reservation made in accordance with paragraph 2 or notified in accordance with paragraph 3 of this article,

(a) modifies, for the Contracting Party which has made or notified the reservation, the provisions of the Protocol to which the reservation relates to the extent of the reservations;

(b) modifies those provisions to the same extent for the other Contracting Parties in their relations with the Contracting Party which made or notified the reservation.

Article 12

In addition to the declarations, notifications and communications provided for in articles 6 and 11 of this Protocol, the Secretary-General shall notify the Contracting Parties and the other States referred to in article 2 of the following:

(a) signatures, ratifications and accessions under article 2;

(b) notifications and declarations under article 3;

(c) the dates of entry into force of this Protocol in accordance with article 4;

(d) the date of entry into force of amendments to this Protocol in accordance with article 6, paragraphs 2, 5, and 7;

(e) denunciations under article 7;

(f) the termination of this Protocol under article 8.

Article 13

After 1 March 1974, the original of this Protocol shall be deposited with the Secretary-General of the United Nations, who shall send certified true copies to all the States referred to in article 2 of this Protocol.

IN WITNESS WHEREOF, the undersigned, being duly authorized thereto, have signed this Protocol.

ANNEX (of the Protocol on Road Markings)

1. For the purposes of applying this annex, the term "Convention" means the Convention on Road Signs and Signals, opened for signature at Vienna on 8 November 1968.

2. This annex contains only additions to and modifications of the corresponding provisions of the Convention.

3. Ad Article 26 of the Convention

Paragraph 2

Additional subparagraph to be inserted immediately after subparagraph (b) of this paragraph

This additional subparagraph shall read as follows:

"Double broken lines may be used to delineate a lane or lanes in which the direction of the traffic flow may be reversed in conformity with Article 23, paragraph 11, of the Convention."

Paragraph 4

Additional phrase to be inserted between "carriageway" and "shall"

With the addition of this phrase, the paragraph shall read as follows:

"For the purposes of this article, longitudinal lines used to mark the edges of the carriageway in order to make them more visible, longitudinal lines connected to transverse lines used to demarcate parking spaces on the carriageway, and longitudinal lines showing a prohibition or restrictions on standing or parking shall not be regarded as longitudinal markings".

4. Ad Article 27 of the Convention

Paragraph 1

Two adjacent continuous lines shall not be used to mark the stop line.

Paragraph 3

Two adjacent broken lines shall not be used to show the line which vehicles may not normally pass when giving way in compliance with the sign B, 1 "Give way."

Paragraph 5

This paragraph shall read as follows:

"To mark cyclist crossings, broken lines consisting of squares or parallelograms shall be used."

5. Ad Article 28 of the Convention

Additional paragraphs to be inserted immediately after paragraph 3 of this Article

These paragraphs shall read as follows:

"A continuous line on the kerb or on the edge of the carriageway shall mean that as far as the line extends, and at the side of the carriageway on which the line is applied, standing and parking are prohibited or are subject to restrictions indicated by other means.

A broken line on the kerb or on the edge of the carriageway shall mean that as far as the line extends, and at the side of the carriageway on which the line is applied, parking is prohibited or is subject to restrictions indicated by other means.

The marking of a traffic lane by a continuous or broken line accompanied by signs or worded road markings designating certain categories of vehicles, such as buses, taxis, etc., shall mean that the use of the lane is reserved to the vehicles so indicated."

6. Ad Article 29 of the Convention

Paragraph 2

This paragraph shall read as follows:

"The road markings shall be white. The term "white" includes shades of silver or light grey. However:

- markings showing places where parking is subject to some conditions or restrictions may be blue;"

- zigzag lines showing places where parking is prohibited shall be yellow;

- the continuous or broken line on the kerb or on the edge of the carriageway to show that standing or parking is prohibited or restricted shall be yellow;"

Additional paragraph to be inserted immediately after paragraph 2 of this Article

This paragraph shall read as follows:

"If a yellow line is used to indicate a prohibition or restrictions on standing or parking, the yellow line shall, if there is a white edge-of-carriageway line, be on the outside of and adjacent to the white line. "

7. Ad Annex 8 to the Convention (Road Markings) – Chapter II (Longitudinal markings) diagram A-1)

A. Dimensions

Paragraph 2

This paragraph shall read as follows:

"The width of continuous or broken lines used for longitudinal markings should be at least 0.10 m (4 in.). The width of a broken line used to indicate the separation between a through lane and an acceleration lane, a deceleration lane or a combination of an acceleration lane and a deceleration lane, should be at least double that of a normal broken line."

Paragraph 5

This paragraph shall read as follows:

"(a) A broken line used for guiding traffic in accordance with Article 26, paragraph 2 (a) (i), of the Convention shall consist of strokes not less than 1 m (3 ft. 4 in.) long. The length of the gaps should normally be from two to four times the length of the strokes. The length of the gaps should not exceed 12 m (40 ft.).

(b) The length of the strokes of a broken line used for warning in accordance with Article 26, paragraph 2 (a) (ii), of the Convention should be from two to four times the length of the gaps."

Paragraph 6

This paragraph shall read as follows:

"A continuous line should be not less than 20 m (65 ft.) long."

B. Traffic lane markings

The distinction between (i) "Outside built-up areas" and (ii) "In built-up areas" shall not apply.

Paragraph 8, first sentence

This sentence shall read as follows: "On two-way carriageways having two lanes, the centre line of the carriageway should be indicated by a longitudinal marking (diagram A-2)."

Paragraph 9

This paragraph shall read as follows:

"On two-way carriageways having three lanes, the lanes should, as a general rule, be indicated by broken lines (diagram A-3). One or two continuous lines or a broken line adjacent to a continuous line should be used only in specific cases. Two continuous lines may be used on approaches to hill crests, intersections and level crossings and where there is reduced visibility":

Paragraph 10

This paragraph shall read as follows:

"On two-way carriageways having more than three lanes, the two directions of traffic should be separated by a continuous line. However, on the approaches to level crossings and in other special circumstances, two continuous lines may be used. The lanes shall be marked by broken lines (diagram A-4). When only one continuous line is used it shall be wider than the lane-lines used on the same section of road."

Paragraph 11

This paragraph shall read as follows:

"If the additional subparagraph inserted after Article 26, paragraph 2 (b), of the Convention is applied, each edge of the reversible lane (s) may be marked by a double broken warning line used in conformity with Article 26, paragraph 2 (a) (ii), of the Convention (diagrams A-5 and A-6)."

Additional paragraph to be inserted immediately after paragraph 11

This paragraph shall read as follows:

"Diagram A-7 gives an example of the marking of a one-way road. Diagram A-8 gives an example of the marking of a carriageway of a motorway."

Paragraph 13

The words "diagrams 2 and 3" shall read: "diagram A-31."

Additional paragraph to be inserted after paragraph 13

This paragraph shall read as follows:

"Diagrams A-9 and A-10 give examples of the marking of acceleration lanes and of deceleration lanes. Diagram A-11 gives an example of the marking of a combination of an acceleration lane and a deceleration lane."

C. Markings for particular situations

Paragraph 14

The words "diagram 4" and "diagrams 5 and 6" shall be replaced by "diagram A-33".

Paragraph 15

This paragraph shall read as follows:

"'Range of vision' means the distance at which an object of a certain height placed on the carriageway can be seen by an observer on the carriageway whose eye is at the same height or lower.¹¹⁹ When it is necessary to prohibit the use of the part of the carriageway reserved for oncoming traffic at certain intersections, or at places where the range of vision is restricted (hill crest, bend in the road, etc.) or on sections where the carriageway is narrow or has some other peculiarity, restrictions should be imposed, on sections where the range of vision is less than a certain minimum M, by means of continuous lines laid out in accordance with diagram A-12 to A-19. Where local circumstances make it impossible to use continuous lines, warning lines in conformity with Article 26, paragraph 2 (a) (ii), of the Convention should be used."

Paragraph 16

This paragraph shall read as follows:

"The value to be adopted for M varies with road and traffic conditions. In the diagrams A-12 to A-19, A (or D) is the point where the range of vision becomes less than M, while C (or B) is the point where the range of vision again begins to exceed M."

Paragraph 17

This paragraph shall read as follows:

"Diagrams A-12 (a), A-12 (b), A-13 (a), A-15 and A-16 give examples of the marking of two-lane roads in various cases (bend or vertical curve, existence or absence of a central area where the range of vision exceeds M in both directions)."

¹¹⁹ In view of the present characteristics of motor vehicle design it is suggested that 1 m (3 ft. 4 in.) should be regarded as the height of the eye and 1.20 m (4 ft.) as the height of the object.

Paragraph 18

This paragraph shall read as follows:

"On three-lane roads two methods are possible:

(a) The carriageway may be reduced to two broader lanes, a procedure which may be regarded as preferable if the road carries a large proportion of two-wheeled vehicles and/or if the section reduced to two lanes is relatively short and remote from any other similar section (diagrams A-12 (c), A-12 (d), A-13 (b), A-17 and A-18).

(b) To take advantage of the full width of the carriageway, one of the two directions of traffic may be offered two lanes. On vertical curves the privileged direction should be the ascending one. Diagram A-12 (e) gives an example of a hill crest where AB and CD do not overlap. Where they do overlap, this type of marking prevents overtaking in the central area where the range of vision is sufficient in both directions. To avoid this the marking of diagram A-13 (c) may be adopted. Diagram A-14 shows the marking of a convex change of slope. The marking is the same whether AB and CD overlap or not. On bends combined with a fairly substantial gradient the same principles may be adopted. On level bends two lanes may be offered to vehicles travelling on the outside of the bend, such vehicles having better visibility when overtaking. Diagram A-19 gives an example of such marking, which is the same whether AB and CD overlap or not."

Paragraphs 19 to 21

The provisions of these paragraphs shall not apply.

Paragraph 22, first sentence

"This sentence shall read as follows: "In diagrams A-20 and A-21, which show the lines used to indicate a change in width of the available carriageway, and in diagram A-22, which shows an obstacle or the beginning of a central reservation necessitating a deviation of the continuous line (s), the inclination of the line (s) should preferably be 1/50 or less on fast roads and 1/20 or less on roads where speeds do not exceed 60 km / h (37 m.p.h)."

Paragraph 23

This paragraph shall read as follows:

"A continuous line should be preceded by a warning line in accordance with Article 26, paragraph 2 (a) (ii), of the Convention for a distance of at least 100 m (333 ft.) on fast roads and at least 50 m (166 ft.) on roads where speeds do not exceed 60km/h. This warning line may be supplemented or replaced by deviation arrows (deflecting arrows). Diagrams A-23 and A-24 give examples of such arrows. Where more than two arrows are used, the distance between successive arrows should diminish as the hazard is approached (diagrams A-25 and A-26)."

D. Border lines indicating the limits of the carriageway

Paragraph 26

Additional sentences to be inserted at the end of this paragraph

These sentences shall read as follows:

"The width of the border line should be at least 0.10 m (4 in.). The width of the border line on a motorway or similar road should be at least 0.15 m (6 in.)."

E. Marking of obstructions

Paragraph 27

This paragraph shall read as follows:

"Diagrams A-22 and A-27 give examples of the markings to be used near an island or any other obstruction on the carriageway."

F. Guide lines and arrows at intersections

Paragraph 28

This paragraph shall read as follows:

"At certain intersections, if it is desirable to show drivers how to cross the intersection and how to turn left in countries with right-hand traffic or how to turn right in countries with left-hand traffic, guide lines or arrows may be used. The recommended length of strokes and gaps is 0.50 m (1 ft. 8 in.) (diagrams A-28 and A-29). The guide lines shown in diagram A-29 (a) may be supplemented by arrows. The arrows shown in diagram A-29 (b) may be supplemented by guide lines."

Ad Annex 8 to the Convention (Road markings) Chapter III (Transverse markings)

B. Stop lines

Paragraph 30

A reference to diagram A-30 shall be added at the end of this paragraph.

Paragraph 32

This paragraph shall read as follows:

"Stop lines may be supplemented by longitudinal lines (diagram A-31). They may also be supplemented by the word "STOP" inscribed on the carriageway (diagram A-32)."

C. Line indicating points at which drivers must give way

Paragraph 33

This paragraph shall read as follows:

"The minimum width of the line should be 0.20 m (8 in.) and the maximum width 0.60 m (24 in.) (diagram A-34 (a)). The length of the strokes should be at least twice their width. The line may be replaced by triangles marked side by side on the ground with their vertices pointing towards the driver who is required to give way. The bases of these triangles should measure at least 0.40 m (16 in.) but not more than 0.60 m (24 in.) and their height should be at least 0.60 m (24 in.) but not more than 0.70 m (28 in.) (diagram A-34 (b))."

Paragraph 35

This paragraph shall read as follows:

"The marking(s) referred to in paragraph 34 above may be supplemented by a triangle drawn on the carriageway as shown in the examples given in diagrams A-34 and A-35."

D. Pedestrian crossings

Paragraph 37

This paragraph shall read as follows:

"The space between the stripes marking a pedestrian crossing should be at least equal to the width of the stripes and not more than twice that width: the width of a space and stripe together should be between 0.80 m (2 ft. 8 in.) and 1.40 m (4 ft. 8 in.). The minimum width recommended for pedestrian crossings is 2.50 m (8 ft.) on roads on which the speed limit is 60 km / h (37 m.p.h) or less (diagram A-36). On other roads the minimum width of pedestrian crossings is 4 m (13 ft.). For safety reasons, pedestrian crossings on such roads should be equipped with traffic light signals."

E. Cyclist crossings

Paragraph 38

This paragraph shall read as follows:

"Cyclist crossings should be indicated by two broken lines. The broken line should preferably be made up of squares (0.40-0.60) x (0.40-0.60) m [(16-24) x (16-24) in.] separated by gaps equal in length to the side of the squares. The width of the crossings should be not less than 1.80 m (6 ft.) for one-way cycle tracks and not less than 3 m (9 ft. 9 in) for two-way cycle tracks. On oblique crossings the squares may be replaced by parallelograms with their sides parallel respectively to the centre line of the road and to the centre line of the track (diagram A-37). Studs and buttons should not be used. Diagram A-38 gives an example of an intersection where the cycle track is part of a priority road."

9. Ad Annex 8 to the Convention (Road markings)- Chapter IV (Other marking)

A. Lane selection arrow markings

Paragraph 39

This paragraph shall read as follows:

"On roads having sufficient traffic lanes to separate vehicles approaching an intersection, the lanes to be used may be indicated by lane selection arrow markings on the surface of the carriageway (diagrams A-39 to A-41). Lane selection arrows may also be used on a one-way road to confirm the direction of traffic. The lane selection arrows should be not less than 2 m (6 ft. 7 in.) long. They may be supplemented by word markings on the carriageway."

B. Oblique parallel lines

Paragraph 40

This paragraph shall read as follows:

"Oblique parallel lines should be so inclined as to deflect traffic from the area they define. Chevron markings, likewise so inclined as to deflect traffic from the hazard, may be used at points of divergence and convergence (diagram A-42). Diagram A-42 a gives an example of an area which vehicles moving alongside the continuous line must not enter and which vehicles moving alongside the broken line may enter only with care. Diagram A-21 shows the marking of areas entry into which is strictly prohibited."

C. Word markings

Paragraph 42

This paragraph shall read as follows:

"The letters and numerals should be considerably elongated in the direction of traffic movement because of the small angle at which they are seen by approaching drivers. Where approach speeds do not exceed 60 km/h (37 m.p.h) the letters and numerals should be at least 1.60 m (5 ft. 4 in.) in height (diagram A-43 to A-48). Where approach speeds exceed 60 km/h, the letters and numerals should be at least 2.50 m (8 ft.) in height. Examples of letters and numerals 4 m in height are given in diagrams A-49 to A-54."

Paragraph 43

The Provision of this paragraph shall not be applied.

E. Markings on the carriageway and on adjacent structures

(i) Markings indicating parking restrictions

Paragraph 45

This paragraph shall read as follows:

"Diagrams A-55 and A-56 give examples of markings indicating a prohibition on parking."

(ii) Marking of obstructions

Paragraph 46

This paragraph shall read as follows:

"Diagram A-57 gives an example of a marking on an obstacle. Such markings should take the form of alternate black and white or alternate black and yellow stripes."

PART IV

LIST OF CONTRACTING PARTIES TO THE 1968 CONVENTION ON ROAD SIGNS AND SIGNALS

AND

**Declarations and reservations concerning
Article 44 and the technical provisions of
the 1968 Convention on Road Signs and Signals**

List of Contracting Parties to the Convention on Road Signs and Signals
Vienna, 8 November 1968
(56 Contracting Parties at the date of 1 July 2007)

| Countries | Signature | Ratification, Accession ^a , Succession ^d |
|----------------------------------|------------------|-------------------------------------------------------------------|
| Albania | | 6 February 2004 ^a |
| Austria | 8 November 1968 | 11 August 1981 |
| Bahrain | | 4 May 1973 ^a |
| Belarus | 8 November 1968 | 18 June 1974 |
| Belgium | 8 November 1968 | 16 November 1988 |
| Bosnia and Herzegovina | | 12 January 1994 ^d |
| Brazil | 8 November 1968 | |
| Bulgaria | 8 November 1968 | 28 December 1978 |
| Central African Republic | | 3 February 1988 ^a |
| Chile | 8 November 1968 | 27 December 1974 |
| Costa Rica | 8 November 1968 | |
| Côte d'Ivoire | | 24 July 1985 ^a |
| Croatia | | 2 November 1993 ^d |
| Cuba | | 30 September 1977 ^a |
| Czech Republic | | 2 June 1993 ^d |
| Democratic Republic of the Congo | | 25 July 1977 ^a |
| Denmark | 8 November 1968 | 3 November 1986 |
| Ecuador | 8 November 1968 | |
| Estonia | | 24 August 1992 ^a |
| Finland | 16 December 1969 | 1 April 1985 |
| France | 8 November 1968 | 9 December 1971 |
| Georgia | | 15 May 2001 ^a |
| Germany | 8 November 1968 | 3 August 1978 |
| Ghana | 22 August 1969 | |
| Greece | | 18 December 1986 ^a |
| Holy See | 8 November 1968 | |
| Hungary | 8 November 1968 | 16 March 1976 |
| India | | 10 March 1980 ^a |
| Indonesia | 8 November 1968 | |
| Iran (Islamic Republic of) | 8 November 1968 | 21 May 1976 |
| Iraq | | 18 December 1988 ^a |
| Italy | 8 November 1968 | 7 February 1997 |
| Kazakhstan | | 4 April 1994 ^a |
| Kuwait | | 13 May 1980 ^a |
| Kyrgyzstan | | 30 August 2006 ^a |
| Latvia | | 19 October 1992 ^a |
| Liberia | | 16 September 2005 ^a |
| Lithuania | | 20 November 1991 ^a |

| Countries | Signature | Ratification, Accession ^a , Succession ^d |
|-----------------------------------------------------------|------------------|-------------------------------------------------------------------|
| Luxembourg | 8 November 1968 | 25 November 1975 |
| Mexico | 8 November 1968 | |
| Mongolia | | 19 December 1997 ^a |
| Montenegro | | 23 October 2006 ^d |
| Morocco | | 29 December 1982 ^a |
| Norway | 23 December 1969 | 1 April 1985 |
| Pakistan | | 14 January 1980 ^a |
| Philippines | 8 November 1968 | 27 December 1973 |
| Poland | 8 November 1968 | 23 August 1984 |
| Portugal | 8 November 1968 | |
| Republic of Korea | 29 December 1969 | |
| Romania | 8 November 1968 | 9 December 1980 |
| Russian Federation | 8 November 1968 | 7 June 1974 |
| San Marino | 8 November 1968 | 20 July 1970 |
| Senegal | | 19 April 1972 ^a |
| Serbia | | 12 March 2001 ^d |
| Seychelles | | 11 April 1977 ^a |
| Slovakia | | 28 May 1993 ^d |
| Spain | 8 November 1968 | |
| Sweden | 8 November 1968 | 25 July 1985 |
| Switzerland | 8 November 1968 | 11 December 1991 |
| Tajikistan | | 9 March 1994 ^a |
| Thailand | 8 November 1968 | |
| The Former Yugoslav Republic of Macedonia ³ | | 20 December 1999 ^d |
| Tunisia | | 5 January 2004 ^a |
| Turkmenistan | | 14 June 1993 ^a |
| Ukraine | 8 November 1968 | 12 July 1974 |
| United Arab Emirates | | 10 January 2007 ^a |
| United Kingdom of Great Britain and Northern Ireland | 8 November 1968 | |
| Uzbekistan | | 17 January 1995 ^a |
| Venezuela (Bolivarian Republic of) | 8 November 1968 | |

Declarations and Reservations made by countries concerning article 44 and the technical provisions of the 1968 Convention on Road Signs and Signals

(Unless otherwise indicated, the declarations and reservations were made upon ratification, accession or succession.)

Austria

Reservations:

1. Article 10 (6) of the Convention on Road Signs and Signals is applied with the exception that the sign B, 2^a is announced in advance by the sign B, 1 supplemented by a rectangular panel bearing the symbol "STOP" and a figure indicating the distance to sign B, 2^a.
2. Article 23 (1) (a) (i), article 23 (2) and article 23 (3) of the Convention on Road Signs and Signals are applied with the exception that the green light may also be flashing. The flashing of the green light signifies that the green phase will end immediately.
3. Paragraph 6 (signs E, 19 and E, 20) of Annex 5, section F of the Convention on Road Signs and Signals is not applied.

Belarus

Reservation and declarations made upon signature and confirmed upon ratification:

The Byelorussian Soviet Socialist Republic does not consider itself bound by the provisions of article 44 of the Convention on Road Signs and Signals stating that disputes which relate to the interpretation or application of the Convention may be referred, at the request of any of the Parties concerned, to the International Court of Justice for decision.

Belgium

16 May 1989 Reservations to articles 10 (6) and 23 (7), and annex 5, section F, 6.

Bulgaria

Reservation made upon ratification:

The inscription of words on informative signs (i) to (v) inclusive of article 5, paragraph 1 (c), shall be duplicated in the People's Republic of Bulgaria by a transliteration into Latin characters solely to indicate the terminal points of international routes passing through the People's Republic of Bulgaria and places of interest to international tourism.

Declaration made upon ratification:

In the People's Republic of Bulgaria mopeds are treated as motor cycles for the purposes of the application of the Convention on Road Signs and Signals [art. 46, para. 2 (b)].

Côte d'Ivoire

Reservations:

Pursuant to article 46, paragraph 1, [of the Convention] the Republic of the Ivory Coast does not consider itself bound by the provisions of article 44, under which "Any dispute between

two or more Contracting Parties which relates to the interpretation or application of this Convention and which the Parties are unable to settle by negotiation or other means of settlement may be referred, at the request of any of the Contracting Parties concerned, to the International Court of Justice for decision.

Cuba

The Revolutionary Government of the Republic of Cuba does not consider itself bound by the provisions of article 44 of the Convention, under which the International Court of Justice is to have compulsory jurisdiction in any dispute which may arise regarding the interpretation or application of the Convention. With regard to the competence of the International Court of Justice, Cuba maintains that, in order for a dispute to be submitted for settlement by the Court, the consent of all the parties concerned in the dispute must be obtained in each individual case.

The Republic of Cuba declares that it treats mopeds as motor cycles, in accordance with article 46 (2.b) of the Convention.

Democratic Republic of the Congo

With reference to the pertinent provisions of the Convention Zaire shall not treat mopeds as motor cycles.

Denmark

Reservation to article 27, paragraph 3 according to which 'give way' shall be indicated both by transverse marking and a plate.

Estonia

Reservation:

Estonia does not consider itself bound by article 44 of the Convention.

Finland

Reservations:

1. With respect to Article 10 paragraph 6 and Section B of Annex 2, paragraph 2 (a) (iii) (Advance warning signs indicating obligatory stop):

Finland reserves the right to use as an advance warning sign indicating an obligatory stop the "GIVE WAY" sign, supplemented with an additional panel including an inscription "STOP" and indicating the distance to the obligatory stop;

2. With respect to Article 18 (Place identification signs):

Finland reserves the right not to use signs E, 9a or E, 9b to indicate the beginning of a built-up area or signs E, 9^c or E, 9^d to indicate the end of such an area. Instead of them symbols are used. A sign corresponding to sign E, 9b is used to indicate the name of a place, but it does not signify the same as sign E, 9^b;

3. [*Reservation withdrawn on 5 September 1995*]

4. With respect to Section F of Annex 5, paragraph 6 (Signs notifying a bus or a tramway stop):

Finland reserves the right to use signs indicating a bus or a tramway stop which differ in shape and colour from signs E, 19 and E, 20."

France

The French Government enters a reservation with regard to the application of article 10, paragraph 6, of the Convention on Road Signs and Signals in respect of metropolitan France and French overseas territories:

Decisions adopted under the Economic Commission for Europe provide for advance warning of sign B, 2² (Stop) by means of sign B, 1, supplemented by a rectangular panel bearing the "Stop" symbol and a figure indicating the distance to sign B, 2². This rule conflicts with the provisions of article 10 of the Convention.

Germany

Reservations:

- Ad article 10, paragraph 6

Article 10, paragraph 6, applies in the Federal Republic of Germany in accordance with paragraph 9 of the annex to the European Agreement of 1 May 1971 supplementing the Convention on Road Signs and Signals.

- Ad article 23, paragraph 7

The Federal Republic of Germany does not consider itself bound by article 23, paragraph 7, of this Convention.

- Ad annex 5, section F, paragraph 6

The Federal Republic of Germany does not consider itself bound regarding the design of signs E, 19 and E, 20.

Greece

[The Government of Greece] declares that it has no intention of treating mopeds as motor cycles.

Hungary

Upon ratification:

[The Presidential Council of the Hungarian People's Republic] considers itself bound by the provisions of article 10, paragraph 6, of the Convention, relative to the [advance warning signs for sign B, 2], subject to its tenor as defined in the European Agreement supplementary thereto.

India

The Government of the Republic of India does not consider itself bound by the provisions of article 44 of the Convention.

India shall treat mopeds as motor cycles.

Indonesia

Indonesia does not consider itself bound by article 44.

In conformity with article 1 moped will be deemed as motor cycle.

LithuaniaReservation:

The Republic of Lithuania does not consider itself bound by article 44 of the Convention.

Luxembourg

With regard to the provisions of article 10, paragraph 6:

The advance warning sign for sign B, 2^a shall be sign B, 1, supplemented by a rectangular panel bearing the word "Stop" and a figure indicating the distance to sign B, 2^a.

With regard to the provisions of article 23, paragraph 7:

Red or yellow arrows shall be used on a black circular background.

MoroccoReservation:

Morocco does not consider itself bound by the contents of article 44 thereof.

Declaration:

Morocco will treat mopeds as motor cycles.

Norway

[For the text of a declaration regarding the application of the Convention to the territories of Svalbard and Jan Mayen see chapter XI.B.19.]

The Government of Norway shall not be bound by the provisions, in article 10 (6), annex 4 A (2) (a) (iii), annex 4 A (2) (a) (v) and annex 5 F (4) and (5) [of the Convention].

RomaniaUpon signature:

The Socialist Republic of Romania does not consider itself bound by the provisions of article 44 of this Convention.

Upon ratification:Declaration and reservation:

[For the text see the declarations and the reservation made in respect of the Convention on Road Traffic concluded at Vienna on 8 November 1968 (chapter XI.b.19).]

Russian Federation

Reservation and declarations made upon signature and confirmed upon ratification:

[Same reservation and declarations, mutatis mutandis, as those reproduced under "Belarus".]

Seychelles

In compliance with article 46 (2) of the Convention on Road Signs and Signals the Government of the Republic of Seychelles declares that [it] treats mopeds as motor cycles.

Spain

In accordance with article 46, . . . Spain does not consider itself bound by article 44 and enters a reservation with respect to article 38.

Sweden

Reservations:

1. Instead of article 10, paragraph 6 of the Convention Sweden will apply the dispositions of paragraph 9 of the annex of the European Agreement supplementing the Convention on Road Signs and Signals.
2. With respect to annex 5, section F, paragraph 4, of the Convention, the signs E, 15-shall have a green ground.
3. With respect to article 44 of the Convention, Sweden opposes that disputes in which it is involved shall be referred to arbitration.

Switzerland

Reservations:

- Ad article 18, paragraph 2 and annex 5, section C

Switzerland does not consider itself bound by the provisions of article 18, paragraph 2 of annex 5, section C.

- Ad article 29, paragraph 2, 2nd sentence

Switzerland does not consider itself bound by the provisions of article 29, paragraph 2, 2nd sentence.

- Ad annex 4, section A, number 2, letter (d)

Switzerland reserves the right to enact, in its domestic legislation, regulations specifying that signs C, 13^{aa} and C, 13^{ab} shall not prohibit drivers from also overtaking motor vehicles whose speed is limited to 30 km/hr.

- Ad annex 5, section F, numbers 4 and 5

Switzerland does not consider itself bound by the introductory provision that signals E, 15; E, 16; E, 17; and E, 18 shall have a blue ground.

Text of the reservations made by Switzerland, as adapted in view of the entry into force of the amendments proposed by Belgium on 31 May 1994:

- Ad article 13 bis, paragraph 2, and annex 1, section E, sub-section II, paragraph 7

Switzerland does not consider itself bound by the provisions of article 13 bis, paragraph 2, and annex 1, section E, subsection II, paragraph 7.

- Ad article 29, paragraph 2, 2nd sentence, article 26 bis, paragraph 1 and annex 2, chapter II, section G

Switzerland does not consider itself bound by article 29, paragraph 2, 2nd sentence, article 26 bis, paragraph 1 and annex 2, chapter II, section G.

- Ad Annex 1, section C, subsection II, paragraph 4, letter (a)

Switzerland reserves the right to enact in its national legislation a regulation specifying that signs C, 13^{aa} and C, 13^{ab} shall not prohibit drivers from also overtaking motor vehicles whose maximum speed is limited to 30 km/h.

- Ad article 10, paragraph 6, 2nd sentence

Switzerland reserves the right to provide in its national legislation, as an advance warning for sign B,2, for an identical sign with an additional panel (model H,1) as indicated in annex 1, section H.

Thailand

- Ad article 13 bis, paragraph 2, and Annex

Thailand will not be bound by article 44 of the Convention.

Thailand will consider mopeds as motor cycles.

Tunisia

Declaration:

In ratifying the accession to the Convention on Road Signs and Signals concluded at Vienna on 8 November 1968, the Republic of Tunisia declares that it does not consider itself bound by article 44 of the Convention and affirms that any dispute which relates to the interpretation or application of this Convention may be submitted to arbitration or to the International Court of Justice only after the prior consent of all the Parties concerned.

Ukraine

Reservation and declarations made upon signature and confirmed upon ratification:

[Same reservation and declarations, mutatis mutandis, as those reproduced under "Belarus".]

Designations of models of danger warning and stop signs under article 46 (2) (a)

| | | |
|----------------------------------|-------------------|-------------------|
| Albania | A ^a | B, 2 ^a |
| Austria | A ^a | B, 2 ^a |
| Bahrain | A ^a | B, 2 ^b |
| Belarus | A ^a | B, 2 ^a |
| Bulgaria | A ^a | B, 2 ^a |
| Central African Republic | A ^a | B, 2 ^a |
| Chile | A ^b | B, 2 ^a |
| Côte d'Ivoire | A ^a | B, 2 ^a |
| Cuba | A ^a | B, 2 ^b |
| Democratic Republic of the Congo | A ^a | B, 2 ^a |
| Denmark | A ^a | B, 2 ^a |
| Estonia | A ^a | B, 2 ^a |
| Finland | A ^a | B, 2 ^a |
| France | (see reservation) | (see reservation) |
| Georgia | A ^a | B, 2 ^a |
| Germany | A ^a | B, 2 ^a |
| Greece | A ^a | B, 2 ^a |
| Hungary | A ^a | B, 2 ^a |
| India | A ^a | B, 2 ^a |
| Iran (Islamic Republic of) | A ^a | B, 2 ^a |
| Italy | A ^a | B, 2 ^a |
| Kuwait | A ^a | B, 2 ^a |
| Latvia | A ^a | B, 2 ^a |
| Lithuania | A ^a | B, 2 ^a |
| Luxembourg | A ^a | B, 2 ^a |
| Mongolia | A ^a | B, 2 ^a |
| Morocco | A ^a | B, 2 ^a |
| Norway | A ^a | B, 2 ^a |
| Pakistan | A ^a | B, 2 ^b |
| Philippines | A ^a | B, 2 ^a |
| Poland | A ^a | B, 2 ^a |
| Romania | A ^a | B, 2 ^a |
| Russian Federation | A ^a | B, 2 ^a |
| San Marino | A ^a | B, 2 ^b |
| Senegal | A ^a | B, 2 ^b |
| Seychelles | A ^a | B, 2 ^a |
| Slovakia | A | B, 2 |
| Sweden | A ^a | B, 2 ^a |
| Switzerland | A ^a | B, 2 ^a |
| Tunisia | A ^a | B, 2 ^a |
| Turkmenistan | A ^a | B, 2 ^a |
| Ukraine | A ^a | B, 2 ^a |
| Uzbekistan | A ^a | B, 2 ^a |

Notes

1. On 31 May 1994, the Secretary-General circulated amendments proposed by the Government of Belgium in accordance with article 41 (1) of the Convention.

a) In this regard, the Secretary-General received the following communications from Contracting Parties:

Austria (30 May 1995):

The Republic of Austria while not rejecting the amendments proposed by Belgium according to article 41 paragraph 2 (a) [of the Convention] declares the following reservation:

The Republic of Austria declares that Figures [paragraphs] 4 and 6 of Annex 1, section G, subsection V to the Convention on Road Signs and Signals shall not be applied.

Chile (26 June 1995):

[The Government of Chile] hereby informs the Secretary-General that the Government of Chile accepts these proposed amendments.

However, without prejudice to the foregoing, it wishes to make some comments intended to clarify the proposed text. Thus although it agrees to substitute the word "mass" for the word "weight" throughout the text, it believes that the States parties should be allowed a certain period of time in which to make the necessary adjustments.

In annex 1, entitled "Road signs" (Signos camineros), the term Señales viales should be used whenever the signs referred to include those used on any transport route in the territory, not only on roads.

The proposed amendment to article 10, paragraph 6, should serve as an alternative to the Convention's current provisions, so that each Contracting Party may opt for the alternative that it finds more suitable.

The wording of article 13 *bis*, paragraph 2, should be changed to make it easier to understand.

The symbol mentioned in annex 1, section A, subsection II, paragraph 5, refers to swing bridges or drawbridges and not to suspension bridges; this should be rectified.

The symbol mentioned in annex 1, section A, subsection II, paragraph 25, refers to level-crossings with gates and not to bridges; this should be rectified.

Germany (31 May 1995):

The proposals contain a revision of the Convention, whereby the location of the provisions and the references between the provisions were changed. For reasons of clarity, also the already existing reservations and declarations are hereinafter adjusted and/or confirmed.

1. Reservations

1. 1. Reservation on Article 10 paragraph 6

Article 10 paragraph 6 applies in the Federal Republic of Germany subject to paragraph 9 of the Annex to the European Agreement of 1 May 1971 supplementing this Convention.

1.2. Reservation on Article 23 paragraph 7

The Federal Republic of Germany does not consider itself bound by Article 23 paragraph 7.

1.3. Reservation on Annex I section C subsection II paragraph 1: Prohibition and restriction of entry.

The Federal Republic of Germany does not consider itself bound as far as the design of sign C, 3^s "No entry for any power-driven vehicle drawing a trailer" is concerned.

1.4. Reservation on Annex I section D subsection II paragraph 10: Compulsory direction for vehicles carrying dangerous goods.

The Federal Republic of Germany does not consider itself bound as far as the design of signs D, 10^a, D, 10^b, D, 10^c is concerned.

1.5. Reservation on Annex I section E subsection II paragraph 13: Signs notifying a bus or tramway stop.

The Federal Republic of Germany does not consider itself bound as far as the design of signs E 15 "Bus Stop" and E 16 "Tramway Stop" is concerned.

1.6. Reservation on Annex I section E subsection II paragraph 8: Signs having zonal validity.

The Federal Republic of Germany reserves the right to depict signs having zonal validity on a square panel.

1.7. Reservation on Annex I section G subsection I paragraph 1: General characteristics and symbols.

The Federal Republic of Germany reserves the right to give a rectangular shape to informative signs, especially to those indicating the number and direction of lanes.

1.8. Reservation on Annex I section G subsection V paragraph 7: Sign notifying advised itinerary for heavy vehicles.

The Federal Republic of Germany does not consider itself bound as far as the design of sign G, 18 "Advised itinerary for heavy vehicles" is concerned.

1.9. Reservation on Annex I section H paragraph 7:

The Federal Republic of Germany reserves the right to indicate a slippery road section also by means of a main panel (sign B, 1 with the symbol of additional panel H, 9).

b) Less than one-third of the Contracting Parties having informed the Secretary-General that they reject the said proposed amendments within the period of twelve months following the date of their circulation i.e. 31 May 1995, and in accordance with article 41 (2) (a) of the Convention, the proposed amendments are deemed to have been accepted.

The amendments entered into force six months after the expiry of the said period of twelve months, i.e. on 30 November 1995 for all Contracting Parties. Paragraphs 4 and 6 of Annex 1, section G, subsection V did not enter into force for Austria only.

2. On 28 September 2004, the Secretary-General circulated amendments proposed by the Government of the Russian Federation in accordance with article 41 (1) of the Convention.

a) In this regard, the Secretary-General received the following communications from the Government of Finland:

On 28 September 2005, the Government of Finland notified the Secretary-General, pursuant to article 41 (1) of the Convention that Finland has no objection to the proposed amendments transmitted on 28 September 2004.

The Government of Finland furthermore informed the Secretary-General of the following:

"... the Government of Finland wishes to recall that the acceptance of the amendments shall not affect the reservations made by the Government of Finland to the said Convention".

b) Less than one-third of the Contracting Parties having informed the Secretary-General that they reject the said proposed amendments within the period of twelve months following the date of their circulation i.e. 28 September 2005, and in accordance with article 41 (2) (a) of the Convention, the proposed amendments are deemed to have been accepted.

The amendments entered into force six months after the expiry of the said period of twelve months, i.e. on 28 March 2006 for all Contracting Parties.

PART V

LIST OF CONTRACTING PARTIES

TO

**THE EUROPEAN AGREEMENT SUPPLEMENTING THE
1968 CONVENTION ON ROAD SIGNS AND SIGNALS**

**List of Contracting Parties to the European Agreement
supplementing the 1968 Convention on Road Signs and Signals**
(Done in Geneva, 1 May 1971)
(29 Contracting Parties at the date of 1 July 2007)

| Countries | Signature | Ratification, Accession ^a , Succession ^d |
|------------------------------------------------------|-------------|----------------------------------------------------------------------|
| Albania | | 6 Jun 2005 ^a |
| Austria | 15 Dec 1972 | 11 Aug 1981 |
| Belarus | | 17 Dec 1974 ^a |
| Belgium | 28 Oct 1971 | 16 Nov 1988 |
| Bosnia and Herzegovina | | 12 Jan 1994 ^d |
| Bulgaria | | 28 Dec 1978 ^a |
| Czech Republic | | 2 Jun 1993 ^d |
| Denmark | 2 May 1972 | 3 Nov 1986 |
| Estonia | | 30 Nov 1993 ^a |
| Finland | 22 Dec 1972 | 1 Apr 1985 |
| France | 29 Dec 1972 | 16 Jan 1974 |
| Georgia | | 15 May 2001 ^a |
| Germany | 28 May 1971 | 3 Aug 1978 |
| Greece | | 18 Dec 1986 ^a |
| Hungary | 29 Dec 1972 | 16 Mar 1976 |
| Italy | | 7 Feb 1997 ^a |
| Latvia | | 20 Nov 2001 ^a |
| Lithuania | | 31 Jan 1992 ^a |
| Luxembourg | 25 May 1971 | 25 Nov 1975 |
| Montenegro | | 23 Oct 2006 ^d |
| Poland | | 23 Aug 1984 ^a |
| Romania | 6 Oct 1972 | 9 Dec 1980 |
| Russian Federation | | 27 Sep 1974 ^a |
| Serbia | | 12 Mar 2001 ^d |
| Slovakia | | 28 May 1993 ^d |
| Sweden | 1 Feb 1972 | 25 Jul 1985 |
| Switzerland | 31 Oct 1972 | 11 Dec 1991 |
| The Former Yugoslav Republic of Macedonia | | 20 Dec 1999 ^d |
| Ukraine | | 30 Dec 1974 ^a |
| United Kingdom of Great Britain and Northern Ireland | 27 Oct 1971 | |

Declarations and Reservations

(Unless otherwise indicated, the declarations and reservations were made upon ratification, accession or succession.)

Belarus

Declaration and reservation:

[For the text see the declaration and reservation made in respect of the European Agreement supplementing the Convention on Road Traffic concluded at Geneva on 1 May 1971 (chapter XI.B-23).]

Denmark

[Same reservations as those under chapter XI.B.20.]

Estonia

Reservation:

Estonia does not consider itself bound by article 9 of the Agreement.

Finland

Declaration:

1. With respect to Annex, paragraph 17 (amendment to Section B of Annex I, paragraphs 2 and 3 of the Convention:

Signs indicating dangerous descent and steep ascent), Finland reserves the right to use sign A, 2^c of the Convention to indicate a dangerous descent, instead of sign A, 2^a. Similarly sign A, 3^c of the Convention is used to indicate a steep ascent instead of sign A, 3^a;

2. With respect to Article 11, paragraph 3, Finland notifies that the reservations Finland has made to Article 18, preamble and paragraphs 4 and 5 of Section F of Annex 5 and paragraph 6 of Section F of Annex 5 of the Convention on Road Signs and Signals shall also apply to the European Agreement Supplementing the Convention.

Reservation:

With respect to Annex, paragraph 22 (amendment to the Note and Section A of Annex 4 of the Convention):

Prohibition signs, Finland reserves the right to use an oblique red bar in signs corresponding to signs C, 3^a -C, 3^b of the Convention."

(5 September 1995) Modification of the text of the reservation made by Finland, as adapted in view of the entry into force of the amendments proposed by Belgium on 31 May 1994 to the 1968 Convention on Road Signs and signals:

The reservation made by Finland [made upon ratification] also applies to signs C, 3^e to C, 3^b and C, 3^m to C, 3ⁿ to the Annex.

France

With regard to article 23, paragraph 3^{bis} (b), of the Agreement on Road Signs and Signals, France intends to retain the possibility of using lights placed on the side opposite to the direction of traffic, so as to be in a position to convey meanings different from those conveyed by the lights placed on the side appropriate to the direction of traffic.

Germany

Reservations:

- Ad paragraph 3 of the annex (Article 1, subparagraph (l) of the Convention):

The Federal Republic of Germany does not consider itself bound by paragraph 3 of the annex (article 1, subparagraph (l) of the Convention).

- Ad paragraph 15 of the annex (Article 33, paragraph 1, subparagraph (a), No. (i) of the Convention):

The Federal Republic of Germany does not consider itself bound by paragraph 15 of the annex (article 33, paragraph 1, subparagraph (a) No. (i) of the Convention).

Hungary

[Same reservation and declarations, mutatis mutandis, as those made in respect of the European Agreement supplementing the Convention on Road Traffic concluded at Geneva on 1 May 1971 (chapter XI.B-23).]

Poland

Declaration:

The Polish People's Republic will use symbol A, 2^c (dangerous descent) instead of symbol A, 2^a, and symbol A, 3^c (steep ascent) instead of symbol A, 3^a provided for in item 17 of the annex to the aforesaid Agreement in accordance with the provisions of Annex 1, Section B, paragraphs 2 and 3, of the Convention on Road Signs and Signals.

Romania

Reservation and declarations:

[For the text see the reservation and declarations made in respect of the European Agreement supplementing the Convention on Road Traffic concluded at Geneva on 1 May 1971 (chapter XI.B-23).]

Russian Federation

Declaration and reservation:

[For the text see the declaration and reservation made in respect of the European Agreement supplementing the Convention on Road Traffic concluded at Geneva on 1 May 1971 (chapter XI.B-23).]

Sweden

"With respect to paragraph 22 of the annex, signs C, 3^a to C, 3^k shall incorporate an oblique bar."

"The reservations of Sweden to the Convention on Road Signs and Signals also apply to this Agreement."

With regard to article 9:

"Sweden opposes that disputes in which it is involved shall be referred to arbitration."

Switzerland

Reservations:

- Annex, number 9 (article 10, paragraph 6, of the Convention):

Switzerland reserves the right to provide in its national legislation, as an advance warning sign for sign B 2a, for an identical sign with an additional panel (model H, 1) as indicated in annex 1, section H.

- Annex, numbers 9 bis and 22 (article 13 bis and annex 1, section E, subsection II, paragraph 7, of the Convention)

Switzerland does not consider itself bound by the provisions of numbers 9^{bis} and 22 of the annex.

- Annex, paragraph 12 (article 24, paragraph 2, of the Convention)

Switzerland reserves the right to provide in its national legislation for the use of the three-colour system for light signals for pedestrians, in accordance with article 24, paragraph 2, of the Convention.

Ukraine

Declaration and reservation:

[For the text see the declaration and reservation made in respect of the European Agreement supplementing the Convention on Road Traffic concluded at Geneva on 1 May 1971 (chapter XI.B-23).]

Notes

1. The Secretary-General received the following communications from the Contracting Parties as indicated hereinafter:

Germany (26 May 1995):

The Federal Republic of Germany agrees to the proposals subject to the following reservation:

- Reservation on Annex I, section C, subsection II, paragraph 1 to the Convention

The Federal Republic reserves the right to define the meaning of sign C., 3^a "No entry for vehicles carrying more than a certain quantity of substances liable to cause water pollution" as follows:

"No entry for vehicles with a water endangering cargo."

Switzerland (23 May 1995):

[The Government of Switzerland] has no objection to the amendments proposed by Belgium. The reservations entered previously [with regard to the Agreement] are hereby abrogated and replaced by the following: (see under "Reservations and Declarations").

Those reservations made with regard to the Agreement made upon ratification and which were abrogated read as follows:

- Ad number 9 of the annex (article 10, paragraph 6, of the Convention)

Switzerland reserves the right to make provision in its domestic legislation, to give advance warning of sign B,2^a, for an identical sign supplemented by a panel conforming to model 1, reproduced in annex 7 to the Convention.

- Ad numbers 10 and 27 of the annex (article 18, paragraph 2, and annex 5, section C, of the Convention)

Switzerland does not consider itself bound by the provisions of numbers 10 and 27 of the annex.

- Ad number 12 of the annex (article 24, paragraph 2, of the Convention)

Switzerland reserves the right to make provision in its domestic legislation for the three-colour system for light signals for pedestrians, pursuant to article 24, paragraph 2, of the Convention.

- Ad number 22 of the annex (annex 4, section A, number 2, letter (a) (iii), of the Convention)

Switzerland reserves the right to enact, in its domestic legislation, regulations specifying that access to roads marked by additional sign No. 1, reproduced in the appendix to the annex, is prohibited for vehicles transporting dangerous goods of any type.

2. Less than one third of the Contracting Parties having informed the Secretary-General that they reject the said proposed amendments within the period of twelve months following the date of their circulation (i.e. 27 May 1994), and in accordance with article 6(2)(a) of the Agreement, the proposed amendments are deemed to have been accepted. The amendments entered into force on 27 November 1995. The amendments relating to annex I, section C, subsection II of the Convention will enter into force for Germany only as modified by the reservation.

3. On 28 September 2004, the Secretary-General circulated amendments proposed by the Russian Federation.

In this regard, communications were received from the following States on the dates indicated hereinafter:

Switzerland (26 September 2005):

Switzerland has no objection to the proposed amendment transmitted on 28 September 2004.

Finland (28 September 2005):

Finland has no objection to the proposed amendment transmitted on 28 September 2004.

The Government of Finland furthermore informed the Secretary-General of the following:

" ... the Government of Finland wishes to recall that the acceptance of the amendments shall not affect the reservations made by the Government of Finland to the said Agreement."

PART VI

LIST OF CONTRACTING PARTIES

TO

**THE PROTOCOL ON ROAD MARKINGS, ADDITIONAL TO THE
EUROPEAN AGREEMENT SUPPLEMENTING THE CONVENTION
ON ROAD SIGNS AND SIGNALS**

**List of Contracting Parties to the Protocol on Road Markings supplementing
the Convention on Road Signs and Signals
Done at Geneva on 1 March 1973
(24 Contracting Parties at the date of 1 July 2007)**

| Countries | Signature | Ratification, Accession ^a , Succession ^d |
|----------------------------------------------|------------------|-------------------------------------------------------------------|
| Albania | | 6 June 2005 ^a |
| Austria | 27 February 1974 | 11 August 1981 |
| Belarus | | 25 April 1984 ^a |
| Belgium | 13 August 1973 | 16 November 1988 |
| Bosnia and Herzegovina | | 12 January 1994 ^d |
| Bulgaria | | 28 December 1978 ^a |
| Czech Republic | | 2 June 1993 ^d |
| Denmark | | 3 November 1986 ^a |
| Finland | | 1 April 1985 ^a |
| Georgia | | 15 May 2001 ^a |
| Germany | 15 November 1973 | 3 August 1978 |
| Greece | | 18 December 1986 ^a |
| Hungary | 18 December 1973 | 16 March 1976 |
| Italy | | 7 February 1997 ^a |
| Luxembourg | 4 July 1973 | 25 November 1975 |
| Montenegro | | 23 October 2006 ^d |
| Poland | | 23 August 1984 ^a |
| Russian Federation | | 6 April 1984 ^a |
| Serbia | | 12 March 2001 ^d |
| Slovakia | | 28 May 1993 ^d |
| Sweden | | 25 July 1985 ^a |
| Switzerland | 20 March 1973 | 11 December 1991 |
| The Former Yugoslav Republic of Macedonia | | 20 December 1999 ^d |
| Ukraine | | 9 May 1984 ^a |

Declarations and Reservations made by countries concerning article 9 and the technical provisions of the 1973 Protocol on Road Markings

(Unless otherwise indicated, the declarations and reservations were made upon ratification, accession or succession.)

Austria

Reservation:

"Paragraph 6 of the Annex to the Protocol on Road Markings Additional to the European Agreement Supplementing the Convention on Road Signs and Signals (referring to article 29 of the Convention) is applied with the exception of the provision under paragraph 2 according to which road markings have to be white."

Belarus

The Byelorussian Soviet Socialist Republic, does not consider itself bound by the provisions of article 9 of the Protocol on Road Markings of 1 March 1983, additional to the European Agreement of 1971 supplementing the Convention on Road Signs and Signals of 1968 [.]

Denmark

[Same reservations as those made to the Convention]

Reservation:

Concerning point 4 of the Annex, which refers to Article 27 paragraph 5, regarding the lines to mark cycle tracks.

Finland

Reservation:

"With respect to Annex, paragraph 6 (amendment to Article 29 paragraph 2 of the Convention), Finland reserves the right to use yellow colour for the continuous line between the opposite directions of traffic."

5 September 1995 Reservation:

"Whereas Finland has taken into use a danger warning line before the barrier line, which also is yellow; [The Government of Finland declares] that the reservation made by Finland also applies to the barrier line."

Germany

Reservation:

- Ad paragraph 6 of the annex (Article 29, paragraph 2, of the Convention):

The Federal Republic of Germany does not consider itself bound by the provision that the zigzag lines showing places where parking is prohibited shall be yellow.

Hungary

[Same reservation and declaration, *mutatis mutandis*, as those made in respect of the European Agreement supplementing the Convention on Road Traffic done at Geneva on 1 May 1971.]

Poland

Declaration:

“All the road markings provided for in item 6, paragraph 2, of the Annex to the said Protocol shall be white.”

Russian Federation

[Same declaration as the one reproduced under Belarus.]

Sweden

“The reservations of Sweden to the Convention on Road Signs and Signals and the European Agreement supplementing that Convention also apply to this Protocol.”

Switzerland

Reservations:

- Ad number 4 of the annex (article 27, paragraph 5, of the Convention)

Switzerland implements article 27, paragraph 5, of the Convention, but not in the manner provided for in number 4 of the annex.

- Ad number 6 of the annex (article 29, paragraph 2 of the Convention)

Switzerland does not consider itself bound by article 29, paragraph 2, 1st and 2nd sentences, of the Convention, in the version given in number 6 of the annex.

Ukraine

[Same declaration as the one reproduced under Belarus.]

ALPHABETICAL INDEX
OF
THE VIENNA CONVENTION ON ROAD SIGNS AND SIGNALS,
THE EUROPEAN AGREEMENT SUPPLEMENTING THE
CONVENTION
AND
ITS ADDITIONAL PROTOCOL

| Alphabetical index | Convention | | | European Agreement | | | Additional Protocol | | |
|-------------------------------------------------|-------------------------|--------------------|----------|----------------------|------------------|----------------------|-------------------------------------|------------------------------|--|
| | Articles | Annexes / Sections | Diagrams | Articles | Annex / Sections | Articles | Annex | Diagrams | |
| A | | | | | | | | | |
| Accession | 37.3, 38, 39.2 | | | 2.3, 4.2, 6.8 | | 2.3, 4.2, 6.8 | | | |
| Additional panels (see signs) | | | | | | | | | |
| Advised itinerary for heavy vehicles | | 1.G.V.7 | | | | | | | |
| Advisory speed | | 1.G.V.6 | | | | | | | |
| Agreement on Signs for Road Works, of 1955 | | | | | | | | | |
| Airfield | | 1.A.II.30 | | | | | | | |
| Amendments | 41 | | | | | | | | |
| - Acceptance | 41.2 (a) & 41.5 (a) | | | 6 | | 6 | | | |
| - Adoption | 41.5 (a) | | | 6.1-3 & 6.5-6 | | 6.1-3 & 6.5-6 | | | |
| - Agreement between Contracting Parties (Annex) | | | | 6.5 (a) | | 6.5 (a) | | | |
| - Convocation of a conference | 41.2 (b) & 41.4 | | | 6.7 | | 6.7 | | | |
| - Entry into force | 41.2 & 41.5 | | | 6.2-4 | | 6.2-4 | | | |
| - Notification | 41.2-3 & 41.5 | | | 6.2 & 6.5 | | 6.2 & 6.5 | | | |
| - Proposals (submission) | 41.1 & 41.4 | | | 6.2-3, 6.5 & 6.8 | | 6.2-3, 6.5 & 6.8 | | | |
| - Rejection | 41.2-3, 41.5 (b) & 41.6 | | | 6.1 & 6.4 | | 6.1 & 6.4 | | | |
| Arrows | 28, 29.3 | 2.IV.A | 2, 3 | 6.2-3, 6.5 (b) & 6.6 | | 6.2-3, 6.5 (b) & 6.6 | Ad Annex 2 (ex-8), II.F, IV.A | A-28-29, A-23, A-39-41 | |

| Alphabetical index | Convention | | | European Agreement | | | Additional Protocol | | |
|-----------------------------------------------|------------------------|----------------------|----------|--------------------|-----------------------------------|----------|----------------------------------|-----------------|--|
| | Articles | Annexes / Sections | Diagrams | Articles | Annex / Sections | Articles | Annex | Diagrams | |
| Audible signals | 24.5 | | | | | | | | |
| B | | | | | | | | | |
| Barriers | | | | | | | | | |
| - For road works | 31.2 | | | | Ad Art. 31.2 | | | | |
| - At level crossings | 33.1 (a), 34, 35, 36.1 | | | | Ad Art. 33.1 (a), Ad Art. 35.1 | | | | |
| Blind pedestrians | 24.5 | | | | | | | | |
| Built-up area | | | | | | | | | |
| - Beginning / End-of | 13.2 & 13 bis 2 | 1.E.II.7 | | | Ad Annex 1.E.II.7 | | | | |
| - Definition | 1 (b) | | | | Ad Art. 1 (b) | | | | |
| - Number of silhouettes on a prohibition sign | | | | | Ad Annex 1.C.II.1 (d) | | | | |
| - Traffic lane markings | | | | | | | | | |
| Bus lane | | | | | | | | | |
| Bus or tramway stop | 28.3 | 2.II.A.6, B.11-13 | 2-3 | | | | Ad Annex 2 (ex- 8), II.B (ii) | A-5-11, A-31 | |
| C | | | | | | | | | |
| Carriageway | | | | | | | | | |
| - Definition | 1 (d) | 2.II.G.28 bis | 28 | | | | | | |
| - Narrows (symbol) | | 1. E.II.13 | | | | | | | |
| | | 1.A.II.4 | | | | | | | |

| Alphabetical index | Convention | | | European Agreement | | | Additional Protocol | | |
|-------------------------------------|-----------------|-------------------------------------------|----------|--------------------|-----------------------------------|----------|----------------------------|----------|--|
| | Articles | Annexes / Sections | Diagrams | Articles | Annex / Sections | Articles | Annex | Diagrams | |
| - Special markings | | 2.IV.E | 26-27 | | | | Ad Annex 2 (ex-8). IV.E | A-55-57 | |
| Cattle or other animals crossing | | I.A.II.15 | | | | | | | |
| Charter of the United Nations | 45 | | | 10 | | 10 | | | |
| Children | | I.A.II.13 | | | | | | | |
| Colours | | | | | | | | | |
| - At level crossings | 33.1, 35 | | | | Ad Art. 33.1 (a), Ad Art. 35.1 | | | | |
| - For road works | 31.2 | | | | Ad Art. 31.2 | | | | |
| - Of stripes | 35 | | | | Ad Art. 35.1 | | | | |
| - Principle (signs) | 8.1 | | | | | | | | |
| - Road markings | 29.2 & 29 bis 1 | 2 | | | | | Ad Art. 29.2 | | |
| - Signs | | | | | | | | | |
| - Additional panel | | I.H.1 | | | | | | | |
| - Danger warning | | I.A.I.1, I.A.II.17 (b) & I.A.II.28 (b) | | | | | | | |
| - Direction, position or indication | | I.G.I.2-4, I.G.V.4 & I.G.V.5 | | | | | | | |
| - Give way | | I.B.1 (a) | | | | | | | |
| - Information | | I.F.1, I.F.II.1 | | | | | | | |
| - Mandatory | | I.D.I.2 | | | | | | | |
| - Priority for oncoming traffic | | I.B.5 (b) | | | | | | | |
| - Priority over oncoming traffic | | I.B.6 (b) | | | | | | | |
| - Priority road | | I.B.3 (a) | | | | | | | |

| Alphabetical index | Convention | | | European Agreement | | | Additional Protocol | | |
|----------------------------------------------------|----------------------------------------------|-----------------------------------------------------------------------------------------------|----------|--------------------|--------------------------------------------------------------------------------------------|-------------|---------------------|----------|--|
| | Articles | Annexes / Sections | Diagrams | Articles | Annex / Sections | Articles | Annex | Diagrams | |
| - Prohibitory | | I.C.I.2, I.C.II.8 (a) & (b), I.C.II.9 (a) (ii) | | | | | | | |
| - Special regulation | | I.E.I, I.E.II.6 (c), I.E.II.7 (b), I.E.II.8 (b) (i), I.E.II.10 (a), I.E.II.12 (a) | | | | | | | |
| - Stop | 32 | I.B.2 (a) | | | Ad Art. 32 | | | | |
| - To mark the edge of the carriageway | | | | | | | | | |
| - Traffic lights | 23, 24, 33 | | | | Ad Art. 23.11 (additional para.), Ad Art 24.1 (a) (ii), 2 & 3, Ad Art 33.1 (a) | | | | |
| Combination of signs | | I.D.II.11 | | | | | | | |
| Conference for revision | 41.2 (b) & 41.4 | | | 6.2-4 | | 6.2-4 | | | |
| Contracting Parties | | | | | | | | | |
| - Amendment (see this word) | | | | | | | | | |
| - Declarations (see this word) | | | | | | | | | |
| - Dispute | 44 | | | 9 | | 9 | | | |
| - Effect of the entry into force of the Convention | 40 | | | 5 | | 5 | | | |
| - Notifications | 9.1, 38, 41.1-2 & 41.5 (b), 42, 46.1-2 | | | 3, 6, 7, 11 | | 3, 6, 7, 11 | | | |
| - Obligations concerning road signs and signals | 3, 4, 5.2 (a) & (b), 8.2, 32, 36 | | | 1 | Ad Art 3.3, Ad Art 32 | 1 | | | |

| Alphabetical index | Convention | | | European Agreement | | | Additional Protocol | | |
|----------------------------------------------------------------|------------------|--------------------|----------|--------------------|------------------|--------------------|---------------------|----------|--|
| | Articles | Annexes / Sections | Diagrams | Articles | Annex / Sections | Articles | Annex | Diagrams | |
| - Possibilities to adopt certain or different rules | 8.2 | | | 10 | | 10 | | | |
| - Reservations | 46 | | | 11 | | 11 | | | |
| Convention concerning the Unification of Road Signals, of 1931 | 40 | | | | | | | | |
| Convention / European Agreement/ Additional Protocol | | | | | | | | | |
| - Accession | 37.3, 38.1 | | | 2.1, 2.3, 4.2, 6.8 | | 2.1, 2.3, 4.2, 6.8 | | | |
| - Amendment (see this word) | 38, 46.1-3, 46.5 | | | 3, 11.1, 11.5 | | 3, 11.1, 11.5 | | | |
| - Declarations | 42 | | | 7 | | 7 | | | |
| - Denunciation | 37.2-3, 46.1-3 | | | 4.2, 11.1-3 | | 4.2, 11.1-3 | | | |
| - Deposit (legal instrument) | 37.2-3, 48 | | | 2.2-3, 13 | | 2.2-3, 13 | | | |
| - Depository | 44 | | | 9 | | 9 | | | |
| - Dispute | 39 | | | 4 | | 4 | | | |
| - Entry into force | | | | | | | | | |
| - Notifications (see this word) | 37.1 | | | 2 | | 2 | | | |
| - Opening for signature | 48 | | | 13 | | 13 | | | |
| - Original | | | | | | | | | |
| - Ratification (see this word) | 46 | | | 11 | | 11 | | | |
| - Reservations | 43 | | | 8 | | 8 | | | |
| - Signature (see this word) | | | | | | | | | |
| - Termination | | | | | | | | | |
| Cross-wind | | 1.A.II.31 | | | | | | | |
| Cycles | | | | | | | | | |
| - Definition | 1 (i) | | | | | | | | |
| - Prohibition of entry | | 1. C.II.1 (c) | | | | | | | |

| Alphabetical index | Convention | | | European Agreement | | Additional Protocol | |
|--------------------------------------------------|-------------------------------------|--------------------|----------|--------------------|-------------------------------------------------|---------------------|----------------------------------------------------------|
| | Articles | Annexes / Sections | Diagrams | Articles | Annex / Sections | Articles | Annex |
| Cycle lane | 1 (e) <u>bis</u> 26 <u>bis</u> 1 | | | | | | |
| - Definition - Marking of lane | | | | | | | |
| Cycle track | 1 (e) <u>ter</u> | I.D.II.4 | | | | | |
| - Definition - Compulsory - Intersection | | | | | | | Ad Annex 2 (ex-8), III. C A-37-38 |
| Cyclists entering or crossing | 27.5 | I.A.II.14, | | | | | Ad Art. 27.5, Ad Annex 2 (ex-8), III. C A-37-38 |
| D | | | | | | | |
| Dangerous bend or bends | | I.A.II.1 | | | | | |
| Dangerous descent | | I.A.II.2 | | | Ad Annex 1.A.II.2 | | |
| Dangerous goods | | I.C.II.1 (e) | | | | | |
| - Prohibition of entry - Compulsory direction | | I.D.II.10 | | | | | |
| Dangerous shoulders | | I.A.II.8 | | | Ad Annex 1.C.II.1 | | |
| Danger warning signs | 5.1 (a), 7.1. 9 | I.A | | | | | |
| - Airfield | | I.A.II.30 | | | Ad Art. 7.1, Ad Art. 9.1, Ad Annex 1.A.II | | |

| Alphabetical index | Convention | | | European Agreement | | Additional Protocol | |
|-----------------------------------------------------------------|---------------|-----------------------|----------|--------------------|-------------------------------|---------------------|-------|
| | Articles | Annexes / Sections | Diagrams | Articles | Annex / Sections | Articles | Annex |
| - Carriageway narrows | | 1.A.II.4 | | | | | |
| - Cattle or other animals crossing | | 1.A.II.15 | | | | | |
| - Children | | 1.A.II.13 | | | | | |
| - Cross-wind | | 1.A.II.31 | | | | | |
| - Cyclists entering or crossing | | 1.A.II.14 | | | | | |
| - Dangerous bend (s) | | 1.A.II.1 | | | | | |
| - Dangerous descent | | 1.A.II.2 | | | Ad Annex 1.A.II.2 | | |
| - Dangerous shoulders | | 1.A.II.8 | | | | | |
| - Falling rocks | | 1.A.II.11 | | | | | |
| - Intersection with a road to whose users drivers must give way | | 1.A.II.20 | | | Ad Annex 1.A.II.20 | | |
| - Intersection with a road the users of which must give way | | 1.A.II.19 | | | | | |
| - Intersection with tramway | | 1.A.II.27 | | | | | |
| - Level-crossings | | 1.A.II.25, 26, 28, 29 | | | Ad Annex 1.A.II.26 (b), 28 | | |
| - Light signals | | 1.A.II.17, 22 | | | Ad Annex 1.A.II.22 | | |
| - Loose gravel | | 1.A.II.10 | | | | | |
| - Models | | 1.A.I | | | | | |
| - Other dangers | | 1.A.II.32 | | | | | |
| - Pedestrian crossing | 24.5 | 1.A.II.12 | | | Ad Annex 1.A.II.12 | | |
| - Priority at an intersection | | 1.A.II.18 | | | Ad Annex 1.A.II.18 | | |
| - Road leads on to quay or river bank | | 1.A.II.6 | | | | | |
| - Road works | 29 bis, 1, 31 | 1.A.II.16 | | | Ad Art. 31.2 | | |

| Alphabetical index | Convention | | | European Agreement | | Additional Protocol | |
|-------------------------------------------------|-------------------|--------------------|----------|--------------------|--------------------------|---------------------|-------|
| | Articles | Annexes / Sections | Diagrams | Articles | Annex / Sections | Articles | Annex |
| - Roundabout | | 1.A.II.21 | | | | | |
| - Slippery road | | 1.A.II.9 | | | | | |
| - Steep ascent | | 1.A.II.3 | | | Ad Annex 1.A.II.5 | | |
| - Swing bridge | | 1.A.II.5, 29 | | | | | |
| - Traffic congestion | | 1.A.II.24 | | | | | |
| - Two-way traffic | | 1.A.II.23 | | | | | |
| - Uneven road | | 1.A.II.7 | | | | | |
| Declarations | 38, 46, 1-5 | | | 3, 11.1, 11.5 | | 3, 11.1, 11.5 | |
| Denunciation | 42 | | | 7 | | 7 | |
| Deposit (legal instrument) | 37.2-3, 46.1-3 | | | 4.2, 11.1-3 | | 4.2, 11.1-3 | |
| Depositary | 37.2-3, 48 | | | 2.2-3, 13 | | 2.2-3, 13 | |
| Dimension of signs (see signs) | | | | | | | |
| Dimensions of road markings (see road markings) | | | | | | | |
| Direction of traffic (Definition) | 1 (t) | | | | | | |
| Direction, position or indication signs | 5. 1 (c) (ii), 16 | 1. G | | | Ad Annex 1.G.II, III & V | | |
| - Advance direction | 15 | 1.G.II.1, 2 | | | Ad Annex 1.G.II.2 | | |

| Alphabetical index | Convention | | | European Agreement | | Additional Protocol | |
|-----------------------------------------|------------|--------------------|----------|--------------------|------------------------|---------------------|-------|
| | Articles | Annexes / Sections | Diagrams | Articles | Annex / Sections | Articles | Annex |
| - Advisory speed | | I.G.V.6 | | | | | |
| - Characteristics | | I.G.I | | | | | |
| - Closure of a traffic lane | | I.G.V.2 | | | | | |
| - Confirmatory | 19 | I.G.IV | | | | | |
| - Direction | 16 | I.G.III | | | Ad Annex 1.G.III.1 & 2 | | |
| - Emergency exits | | I.G.V.11 | | | | | |
| - Escape lane | | I.G.V.8 | | | | | |
| - Exit from a motorway | | I.G.V.10 | | | | | |
| - General speed limits | | I.G.V.4 | | | | | |
| - Indication | | I.G.V | | | | | |
| - Itinerary advised for heavy vehicles | | I.G.V.7 | | | | | |
| - No through road | | I.G.V.3 | | | Ad Annex 1.G.V.3 | | |
| - Number and direction of traffic lanes | | I.G.V.1 | | | | | |
| - Pedestrian overpass or underpass | | I.G.V.9 | | | | | |
| - Road open or closed | | I.G.V.5 | | | | | |
| Direction to be followed | | I.D.II.1 | | | Ad Annex 1.D.II.1 | | |
| Dispute (interpretation or application) | 44 | | | 9 | | | 9 |
| Domestic legislation | | | | | | | |
| - Definition | 1 (a) | | | | | | |

| Alphabetical index | Convention | | | European Agreement | | | Additional Protocol | | |
|----------------------------------------------------------------------------------------------------------------------------------------------------------------------------------------------------------------------------|----------------------------------------|----------------------------------|----------|--------------------|----------------------------|----------|---------------------|----------|--|
| | Articles | Annexes / Sections | Diagrams | Articles | Annex / Sections | Articles | Annex | Diagrams | |
| <ul style="list-style-type: none"> - Obligations (rules to be applied) - Recommendations (rules to be introduced) | 26 bis 3 6.4, 7, 23.3 bis (c), 29.4 | | | | Ad Art. 6.4, Ad Art.7.1 | | | | |
| Driver (Definition) | 1 (q) | | | | | | | | |
| E | | | | | | | | | |
| End of | | | | | | | | | |
| <ul style="list-style-type: none"> - Compulsory minimum speed - Priority - Prohibition / Restriction | | I.D.II.8 I.B.4 I.C.II.8 | | | | | | | |
| Entry to / Exit from a | | | | | | | | | |
| <ul style="list-style-type: none"> - Built-up area (see this word) - Road on which the traffic rules are the same as on a motorway - Tunnel where special rules apply - Motorway | | I.E.II.6 I.E.II.9 I.G.V.10 | | | Ad Annex I.E.II.6 | | | | |
| Entry into force of | 39, 40 | | | 4, 5 | | | | | |
| <ul style="list-style-type: none"> - The Convention - The European Agreement - The Additional Protocol | | | | | | | | 4, 5 | |
| Escape lane | | I.G.V.8 | | | | | | | |

| Alphabetical index | Convention | | | European Agreement | | Additional Protocol | |
|----------------------------------------------------------------------------------------------------------------------------------|------------|--------------------|----------|--------------------|-------------------|---------------------|-------|
| | Articles | Annexes / Sections | Diagrams | Articles | Annex / Sections | Articles | Annex |
| European Agreement on Road Markings, of 1957 | | | | 5 | | 5 | |
| European Agreement supplementing the Convention on Road Traffic of 1949 and the Protocol on Road Signs and Signals (replacement) | 40 | | | 5 | | 5 | |
| F | | | | | | | |
| Facilities signs (see Information signs) | | | | | | | |
| Falling rocks | | 1.A.II.11 | | | | | |
| First-aid station | | 1.F.II.1 | | | Ad Annex 1.F.II.1 | | |
| Footpath (compulsory) | | 1.D.II.5 | | | | | |
| Form (signs) | | | | | | | |
| - Principle | 8.1 | | | | | | |
| - Signs | | | | | | | |
| - Danger warning | | 1.A.I.1 | | | | | |
| - Direction, position or indication | | 1.G.I.1 | | | | | |
| - Information | | 1.F.I.1 | | | | | |
| - Give way | | 1.B.1 (a) | | | | | |
| - Mandatory | | 1.D.I.1 | | | | | |
| - Priority for oncoming traffic | | 1.B.5 (b) | | | | | |

| Alphabetical index | Convention | | | European Agreement | | Additional Protocol | | |
|----------------------------------|---------------------------|------------------------------------------------------------------------------|----------|--------------------|----------------------------------------|---------------------|----------------------------------------------|----------|
| | Articles | Annexes / Sections | Diagrams | Articles | Annex / Sections | Articles | Annex | Diagrams |
| - Priority over oncoming traffic | | 1.B.6 (b) | | | | | | |
| - Priority road | | 1.B.3 (a) | | | | | | |
| - Prohibitory | | 1.C.I.1, 1.C.II.8 (a), 1.C.II.9 (a) (ii) | | | | | | |
| - Special regulation | | 1.E.I, 1.E.II.3 (a), 1.E.II.8 (a) (i), 1.E.II.10 (b), 1.E.II.12 (a) | | | | | | |
| - Stop | | 1.B.2 (a) | | | | | | |
| G | | | | | | | | |
| Gates (at level crossings) | 33.1 (a), 34, 35, 36.1 | | | | Ad Art. 33.1 (a), Ad Art 35.1 | | | |
| Give way (requirement to) | | 1.A.II.20, 1.B.1 | | | Ad Annex 1.A.II.20, Ad Annex 1.B | | | |
| - Definition | 1 (u) | | | | | | | |
| - Transverse marking | 27.3 | 2.III.C | 22 | | | | Ad Art. 27.3, Ad Annex 2 (ex-8), III.C | A-34-35 |
| H | | | | | | | | |
| Handcarts | | 1.C.II.1 (c) | | | | | | |
| Handicapped persons | | 1.H.6 | | | | | | |
| Hospital | | 1.E.II.11 | | | | | | |
| | | | | | Ad Art.1 (l) (additional para.) | | | |

| Alphabetical index | Convention | | | European Agreement | | Additional Protocol | |
|-------------------------------------------|-------------|----------------------------|----------|--------------------|---------------------------|---------------------|----------------------------------------------|
| | Articles | Annexes / Sections | Diagrams | Articles | Annex / Sections | Articles | Annex |
| I | | | | | | | |
| Indication signs (see Direction signs) | | | | | | | |
| Information, facilities or service signs | | | | | | | |
| - Characteristics | 5.1 (c) (i) | 1.F | | | Ad Annex 1.F.II | | |
| - First-aid station | | 1.F.I | | | Ad Annex 1.F.II.1 | | |
| - Miscellaneous symbols | | 1.F.II.1 1.F.II.2 | | | Ad Annex 1.F.II.2 | | |
| Inscriptions on roads (see Road markings) | | | | | | | |
| Intersections | | | | | | | |
| - Advance direction signs | 15 | 2.IV.A | | | | | Ad. Annex 2 (ex-8) II.F.28 IV.39 |
| - Arrows | | | | | | | A-28-29 A-39-41 |
| - Definition | 1(f) | | | | | | |
| - Light signal at | 23 | 1.A.II.22 | | | Ad Annex 1.A.II.22 | | |
| - Priorities | 10 | 1.A.II.18-20, 2.III.B-C | 18-22 | | Ad Annex 1.A.II.18, 20 | | Ad. Annex 2 (ex-8). III.B.30-32, III.C.33 |
| - Roundabout | | 1.A.II.21 | | | | | A-30-32, A-34, A-37-38 |
| - With a tramway line | | 1.A.II.27 | | | | | |
| J | | | | | | | |
| Junction (see Intersection) | | | | | | | |

| Alphabetical index | Convention | | | European Agreement | | Additional Protocol | |
|------------------------------------------------------------------------------------------------------------------------------------------------------------------------------------------------------------------------------------------------------------------------------------------------------------------------------------------------------------------------------------------|------------------------------------------------------|-----------------------------------|-------------|--------------------|----------------------------------------------------------------------|---------------------|-------------------------------|
| | Articles | Annexes / Sections | Diagrams | Articles | Annex / Sections | Articles | Annex / Diagrams |
| L Laden mass (Definition) Lanes - Definition - Delineation - For buses - For cycles (Definition) - For public transport (see For buses) - Marking of lanes reserved for certain categories of vehicle - Selection arrow marking Language (signs) Level crossings - Definition - Flashing lights - Light signals | 1 (s) | | | | | | |
| | 26 | | | | | | Ad Art. 26.2 & 26.4 |
| | 1 (e) 26.2 (c) 26 <u>bis</u> . 2 | 1.E.II.2, 2.II.G.28 <u>bis</u> | 28 | | | | |
| | 1 (e) <u>bis</u> , 26 <u>bis</u> .1 | | | | | | |
| | 26 <u>bis</u> .1 | 2.IV.A | 2-3, 19, 23 | | | | Ad Annex 2 (ex-8), IV.A.39 |
| | 8.5, 14.2-4 | | | | | | |
| | 33-36 | 1.A.II.25, 26, 28 & 29 | | | Ad Art. 33.1 (a) & 33.2, Ad Art. 35.1, Ad Annex 1.A.II.26 & 28 | | |
| | 1 (g) 23.1 (b)(i), 23.12, 33.1 (a) 33, 34.2 | 1.A.II.17 & 22 | | | | Ad Annex 1.A.II.22 | |

| Alphabetical index | Convention | | | European Agreement | | Additional Protocol | | |
|-----------------------------------|---------------------------|-------------------------------------------------------------|-------------------------|--------------------|------------------|---------------------|----------------------------------------------------------------------------------------------------------------------------------------------------------------------------------------------------------------------|-------------------------------------------------------------------------------------------------------------------------------------|
| | Articles | Annexes / Sections | Diagrams | Articles | Annex / Sections | Articles | Annex | Diagrams |
| Lines | 26 | | | | | | | |
| - Broken | 26.2-3, 28.2 | 2.II.A.2-5, 2.II B, 2.II.C.14, 17, 2.II.G | 1-14, 19, 28 (a) | | | | Ad Art. 26.2, 26.4 Ad Art. 26.2, 28 (additional para.), 29.2 & 5, Ad Annex 2 (ex-8), II.A.2 & 5, II B.8-11 & 13 Ad Art. 27.1, 28 (additional para.) Ad Annex 2 (ex-8) II.A.6 & II.C | A-1-11, A-31, A-33 |
| - Continuous | 26.1, 26.3, 27.1, 28.2 | 2.II.A.2-3, 2.II.B.9-11, 13, 2.II.C, D & E, 2.II.G | 1-3, 5-17, 28 (b) | | | | | |
| - Give way | 27.3 | 2.III.C | 22 | | | | | A-12-26 |
| - Longitudinal | 26.4 | 2.II | 1-17, 28 | | | | | A-32, A-37-38 |
| - Oblique parallel | 28.1-3 | 2.IV.B | 24-25 | | | | | A-1-29, A-31, A-33 |
| - Stop | 27.1 | 2.III.B | 18-19 | | | | | A-21, A-42 |
| - Transverse | 27 | 2.III.B | 18-22 | | | | | A-30-32 III.B |
| - Zagzag | 28.3 | 2. IV. E (i) | 26 | | | | | Ad Art. 27.1, 27.3 & 27.5, Ad Annex 2 (ex-8), III.B.30 & 32, III.C.33 Ad Art.29.2, Ad Annex 2 (ex-8), IV.E (i) |
| Longitudinal markings (see Lines) | | | | | | | | |
| Loose gravel | | 1.A.II.10 | | | | | | |

| Alphabetical index | Convention | | | European Agreement | | Additional Protocol | |
|-----------------------------------------------------------------------------------------------------------------------------------------------------------------------------------------------------------------------------------------------------------------------------------------------------------------------------------------------------------------------------------------------------------------------------------------------------------------------------------------------------|----------------------------|-----------------------------------------------------------------------------------------------------------------------------------------------------------------------------------------|----------|--------------------|-----------------------------------------------|---------------------|---------------------------------------------------------|
| | Articles | Annexes / Sections | Diagrams | Articles | Annex / Sections | Articles | Annex |
| M Mandatory signs - Characteristics - Combination of signs - Compulsory cycle track - Compulsory direction for vehicles carrying dangerous goods - Compulsory footpath - Compulsory minimum speed - Compulsory roundabout - Compulsory track for riders on horseback - Direction to be followed - Pass this side - Snow chains compulsory Markings - Cyclist crossing - Pedestrian crossing - Road markings (see these words) - Temporary | 5.1 (b) (iii), 12, 13.1 | 1.D 1.D.I 1.D.II.11 1.D.II.4 1.D.II.10 1.D.II.5 1.D.II.7, 8 1.D.II.3 1.D.II.6 1.D.II.1 1.D.II.2 1.D.II.9 2.III.E 2.III.D | | | Ad Annex 1.D.I, II Ad Annex 1.D.I, 2 | | |
| | | 27.5 | | | Ad Annex 1.D.II.3 | | Ad Art. 27.5, Ad Annex 2 (ex-8), III.E A-37-38 |
| | | 27.4, 28.2 | | | Ad Annex 1.D.II.1 | | Ad Annex 2 (ex-8), III.D A-36 |
| | | 29 bis | | | | | |

| Alphabetical index | Convention | | | European Agreement | | Additional Protocol | | |
|-----------------------------------------|------------|-----------------------|----------|--------------------|------------------|---------------------|--------------------------------------------------|------------------------|
| | Articles | Annexes / Sections | Diagrams | Articles | Annex / Sections | Articles | Annex | Diagrams |
| - Transverse | 27 | 2.III | 18-22 | | | | Ad Art.27.1, 27.3 & 27.5, Ad Annex 2 (ex-8), III | A-30-32, A-34, A-37-38 |
| Marking of lanes | 26 bis 1 | | | | | | | |
| Marking by lights or reflecting devices | 32 | | | | | | | |
| Minimum speed | | 1.D.II.7 & 8 | | | | | | |
| Models | | 1.A.1 | | | | | | |
| - Danger warning signs | | | | | | | | |
| - Of signs (see Notifications) | | | | | | | | |
| Mopeds | | | | | | | | |
| - Assimilation to motor cycles | 46.2 (b) | | | | | | | |
| - Definition | 1 (k) | | | | | | | |
| - Prohibition of entry | | 1.C.II.1 (g) | | | | | | |
| Motor cycle | | | | | | | | |
| - Definition | 1 (l) | | | | Ad Art. 1 (l) | | | |
| - Prohibition of entry | | 1.C.II.1 (g) | | | | | | |
| Motor vehicles (Definition) | 1 (n) | | | | | | | |
| Motorways (Definition) | 1 (h) | 1.E.II.5, 1.G.II.V.10 | | | | | | |

| Alphabetical index | Convention | | | European Agreement | | Additional Protocol | |
|--------------------------------------|-------------------------------|---------------------------------------------------------|----------|--------------------|-------------------------------------------|---------------------|---------------------------------|
| | Articles | Annexes / Sections | Diagrams | Articles | Annex / Sections | Articles | Annex |
| - Definition | 1 (i) (ii) | | | | | | |
| Parking | | | | | | | |
| - Demarcation of space | 26.4 | | | | | | Ad Art. 26.4 |
| - Regulations | 29.2 | 2.IV.D | | | | | Ad Art. 29.2 & additional para. |
| - Sign | | 1.C.II.9, 1.E.II.8 (a) (ii) & (b) (ii), 1.E.II.12 | | | Ad Annex 1.E.II.12 | | |
| Pass this side | | 1.D.II.2 | | | | | |
| Pedestrians | | | | | | | |
| - Crossing | 13 bis 3, 24.5, 27.4, 28.2 | 1.A.II.12, 1.E.II.10, 2.III.D | | | Ad Annex 1.A.II.12, Ad Annex 1.E.II.10 | | Ad Annex 2 (ex-8), A-36 III.D |
| - Prohibition of entry | | 1.C.II.1 (c) | | | | | |
| - Signals | 24 | 1.D.II.5 | | | Ad Art. 24 | | |
| Pedestrian overpass or underpass | | 1.G.V.9 | | | | | |
| Permissible maximum mass (vehicle) | | | | | | | |
| - Definition | 1 (r) | | | | | | |
| Placement of signs (see Signs) | | | | | | | |
| Position signs (see Direction signs) | | | | | | | |

| Alphabetical index | Convention | | | European Agreement | | | Additional Protocol | | |
|-------------------------------------------|------------------------------|--------------------|----------|--------------------|----------------------------------|----------|---------------------|----------|--|
| | Articles | Annexes / Sections | Diagrams | Articles | Annex / Sections | Articles | Annex | Diagrams | |
| Power-driven vehicle | 1 (m) | I.C.II.1 (c) | | | | | | | |
| - Definition | | | | | | | | | |
| - Prohibition of entry | | | | | | | | | |
| Preselection | | I.E.II.4 | | | | | | | |
| Priority signs | 5.1 (b) (i), 10, 13 bis 2 | I.B | | | Ad Art. 13 bis 2, Ad Annex 1.B | | | | |
| - End of priority | | I.B.4 | | | | | | | |
| - Give way | | I.B.1 | | | Ad Annex 1.B.1 | | | | |
| - Priority for traffic | | I.B.5, 6 | | | | | | | |
| - Priority road | | I.B.3 | | | | | | | |
| - Stop | | I.B.2 | | | | | | | |
| Prohibitory or restrictive signs | 5.1 (b) (ii), 11, 13.1, 13.3 | I.C | | | Ad Art. 10.3 & 6, Ad Annex 1.B.2 | | | | |
| - Characteristics | | I.C.1 | | | Ad Annex 1.C.II. | | | | |
| - Prohibition and restriction of entry | | I.C.II.1 | | | | | Ad Annex 1.C.II.1 | | |
| - End of prohibition or restriction | | I.C.II.8 | | | | | | | |
| - Prohibition of audible warning devices | | I.C.II.6 | | | | | | | |
| - Prohibition of overtaking | | I.C.II.4 | | | | | Ad Annex 1.C.II.4 | | |
| - Prohibition of passing without stopping | | I.C.II.7 | | | | | | | |
| - Prohibition of turning | | I.C.II.2 | | | | | | | |
| - Prohibition of U-turns | | I.C.II.3 | | | | | | | |

| Alphabetical index | Convention | | | European Agreement | | | Additional Protocol | | |
|--------------------------------------------------------------------|-----------------|--------------------|----------|--------------------|-------------------------------------------------------|----------|---------------------|----------|--|
| | Articles | Annexes / Sections | Diagrams | Articles | Annex / Sections | Articles | Annex | Diagrams | |
| - Prohibition or restriction of standing and parking | | I.C.II.9 | | | Ad Annex I.C.II.9 | | | | |
| - Speed limit | 40 | I.C.II.5 | | 5 | 5 | | | | |
| Protocol on Road Signs and Signals of 1949 (replaced) | | | | | | | | | |
| Q | | | | | | | | | |
| Quay (road leads on to) | | I.A.II.6 | | | | | | | |
| R | | | | | | | | | |
| Ratification | 37.2, 38.1, 39 | | | 2.2 | 2.2 | | | | |
| Recommendations (Signs) | 7, 23.3 bis (c) | | | | | | | | |
| Reflecting devices (for marking on roads) | 32 | | | | Ad Art. 32 | | | | |
| Regulation or danger warning applying to one or more traffic lanes | | I.E.II.1 | | | | | | | |
| Reservations | 46 | | | 11 | | | | | |
| Residential area | | | | | Ad Art. 1 (b) (additional para) Ad Annex I.E.II.13 | | | | |

| Alphabetical index | Convention | | | European Agreement | | | Additional Protocol | | |
|---------------------------------------------------------|------------------------|--------------------------------------------------------------------------------------------------|----------------------|--------------------|------------------|----------|---------------------------------------------------------------------------------|------------------------------------------|--|
| | Articles | Annexes / Sections | Diagrams | Articles | Annex / Sections | Articles | Annex | Diagrams | |
| Restrictive signs (see Prohibitory signs) | | | | | | | | | |
| Riverbank (road leads on to) | | 1.A.II.6 | | | | | | | |
| Road | | | | | | | | | |
| - Definition | 1 (c) | | | | | | | | |
| - Open / Closed | | 1.G.V.5 | | | | | | | |
| Road markings | | | | | | | | | |
| - Arrow markings | 2, 25-30 28.1, 29.3 | 2 2.IV.A | 2, 3, 19, 23 | | | | Ad Annex. 2 (ex-8) Ad Annex 2 (ex-8). II.F, IV.4 | A-23, A-28-29, A-39-41 | |
| - Design | 30 | | | | | | | | |
| - Dimensions | 30 | 2.II.A, 2.III.B.30 & 32, 2.III.C.33 & 35, 2.III.D.37 & E.38, 2.IV.A.39, 2.IV.C.43 | 18-21 2-3, 19, 23 | | | | Ad Annex 2 (ex-8). II.A, III.B.30, III.C.33, IV.A.39, IV.C.42-43 | A-30-32, A-34, A-39-41, A-43-54 | |
| - Layout | 30 | | | | | | | | |
| - Longitudinal markings | | 2.II | | | | | Ad Annex 2 (ex-8). II | A-1-29 | |
| - Border lines indicating the limits of the carriageway | | 2.II.D | | | | | Ad Annex 2 (ex-8). II.D | | |
| - Dimensions | | 2.II.A | | | | | Ad Annex 2 (ex-8). II.A | | |
| - Guidelines for turning vehicles | | 2.II.F | | | | | Ad Annex 2 (ex-8). II.F | A-28-29 | |
| - Lane reserved for certain categories of vehicle | | 2.II.G | 28 | | | | | | |

| Alphabetical index | Convention | | | European Agreement | | Additional Protocol | | |
|-------------------------------------------------------------|---------------|--------------------|----------|--------------------|------------------|---------------------|-------------------------------------------------------------------|------------------------------|
| | Articles | Annexes / Sections | Diagrams | Articles | Annex / Sections | Articles | Annex | Diagrams |
| - Marking of obstructions | | 2.II.E | 15-17 | | | | Ad Annex 2 (ex-8), II.E | A-22, A-27 |
| - Particular situations / Continuous lines | | 2.II.C | 4-17 | | | | Ad Annex 2 (ex-8), II.C | A-12-26 |
| - Traffic lane markings in built-up areas | | 2.II.B (ii) | 2-3 | | | | Ad Annex 2 (ex-8), II.B.11-13 | A-5-11 |
| - Traffic lane markings outside built-up areas | | 2.II.B (i) | 1 | | | | Ad Annex 2 (ex-8), II.B.8-10 | A-2-4 |
| - Marking on an obstacle | | 2.IV.E (ii) | 27 | | | | Ad Annex 2 (ex-8), IV.E (ii) | A-57 |
| - Oblique parallel lines | | 2.IV.B | 24-25 | | | | Ad Annex 2 (ex-8), IV.B | A-21, A-42 |
| - Standing and parking regulations | | 2.IV.D | | | | | | |
| - Temporary | 29 bis | | | | | | | |
| - <i>Transverse markings</i> | 27 | 2.III | 18-22 | | | | Ad Art. 27.1, 27.3, 27.5, Ad Annex 2 (ex-8) III | A-30-32, A-34, A-37-38 |
| - Cyclist crossings | 27.5 | 2.III.E | | | | | Ad Art. 27.5, Ad Annex 2 (ex-8), III.E | A-37-38 |
| - Lines indicating points at which drivers must give way | | 2.III.C | 22 | | | | Ad Annex 2 (ex-8), III.C | |
| - Pedestrian crossings | 27.4 | 2.III.D | | | | | Ad Annex 2 (ex-8), III.D | A-36 |
| - Stop lines | | 2.III.B | 18-21 | | | | Ad Annex 2 (ex-8), III.B | A-30-32 |
| - Word markings | 28.1, 3, 29.3 | 2.IV.C | 20 | | | | Ad Art. 29.2 (Additional para.), Ad Annex 2 (ex-8), IV.C | A-43-54 |

| Alphabetical index | Convention | | | European Agreement | | | Additional Protocol | | |
|--------------------------------------------------------------|-------------------------------|------------------------|----------|--------------------|-------------------------------------------------|----------|------------------------------------------------|----------|--|
| | Articles | Annexes / Sections | Diagrams | Articles | Annex / Sections | Articles | Annex | Diagrams | |
| - Zigzag line | 28 | 2.IV.E(i) | 26 | | | | Ad Art. 29.2, Ad Annex 2 (ex-8), IV.E(i) | A-55 | |
| Road signs (see Signs) | 2, 5-21 | 1, 3 | | | Ad Art. 7.1, Ad Art. 9.1, Ad Annex 1.A.II | | | | |
| - Danger warning signs (see these words) | 5.1 (a), 7.1, 9 | 1.A | | | | | | | |
| - Direction, position or indication signs (see these words) | 5.1 (c) (ii), 16 | 1.G | | | Ad Annex 1.G.II, III & V | | | | |
| - Information, facilities or service signs (see these words) | 5.1 (c) (i) | 1.F | | | Ad Annex 1.F.II | | | | |
| - Mandatory signs (see these words) | 5.1 (b) (iii), 12, 13.1 | 1.D | | | Ad Annex 1.D.I & II | | | | |
| - Priority signs (see these words) | 5.1 (b) (i), 10, 13 bis 2 | 1.B | | | Ad Art. 13 bis 2, Ad Annex 1.B | | | | |
| - Prohibitory or restrictive signs (see these words) | 5.1 (b) (ii), 11, 13.1 & 13.3 | 1.C | | | Ad Annex 1.C.II | | | | |
| - Special regulation signs (see these words) | 5.1 (b) (iv) | 1.E | | | Ad Annex 1.E.II | | | | |
| Road works | 29 bis 1, 31 | 1.A.II.16 | | | Ad Art. 31.2 | | | | |
| Roundabout | | 1.A.II.21, 1.D.II.3 | | | | | | | |
| S | | | | | | | | | |
| Semi-trailer (Definition) | 1 (p) | | | | | | | | |

| Alphabetical index | Convention | | | European Agreement | | Additional Protocol | |
|---------------------------------------|------------------------------------------------------------------|-------------------------------------------------------------------------------------------------|----------|--------------------|----------------------------------|---------------------|-------|
| | Articles | Annexes / Sections | Diagrams | Articles | Annex / Sections | Articles | Annex |
| Service signs (see Information signs) | | | | | | | |
| Signature | 37.1, 38.1 | | | 2.1, 11.1 | | 2.1, 11.1 | |
| - Declaration | 38, 46 | | | 3 | | 3 | |
| - Opening for | 37.1 | | | 2.1 | | 2.1 | |
| Signs | 2, 6, 7, 8 | | | | | | |
| - Additional panels | 5.1 (c) (iii), 8.3-5, 9.4, 9.6, 10.6-7, 13.1, 13.bis 4, 15, 21.2 | 1.A.II.29, 1.C.II.4 (b), 5 (b), 6, 9 (a) (iii), 9 (c) (iii)-(vi), 1.D. II.4, 1.E.II.12 (b), 1.H | | | Ad Annex 1.H.1 (additional para) | | |
| - Advance direction | 15 | | | | | | |
| - Confirmatory | 19 | | | | | | |
| - Danger warning | 5.1 (a), 7.1, 9 | 1.A | | | Ad Art 7.1, Ad Annex 1.A.II | | |
| - Dimensions of | 6.4 (b), (c) | | | | Ad Art. 6.4 | | |
| - Danger warning | | 1.A.1.2, 1.A.II.28 (c) | | | | | |
| - Give way | | 1.B.1 (b) | | | | | |
| - Mandatory | | 1.D.1.1 | | | | | |
| - Priority for oncoming traffic | | 1.B.5 (a) | | | | | |
| - Priority over oncoming traffic | | 1.B.6 (c) | | | | | |
| - Priority road | | 1.B.3 (b) | | | | | |
| - Prohibitory | | 1.C.1.1 | | | | | |
| - Stop | | 1.B.2 (b) | | | | | |
| - Direction, position or indication | 5.1 (c) (ii), 16 | 1.G | | | Ad Annex 1.G.II, III & V | | |

| Alphabetical index | Convention | | | European Agreement | | Additional Protocol | |
|--------------------------------------|------------------------------------------------------|--------------------------------------------------------------------------------------------------------------------------|----------|--------------------|---------------------|---------------------|-------|
| | Articles | Annexes / Sections | Diagrams | Articles | Annex / Sections | Articles | Annex |
| - Form of (see the word) | 14, 5 (c), 21 | I.F | | | Ad Annex 1.F.II | | |
| - Informative | 5.1 (c), (i) | I.D | | | Ad Annex 1.D.I & II | | |
| - Information, facilities or service | 5.1 (b) (iii), 12, 13.1 | | | | Ad Art. 18 | | |
| - Mandatory | 18 | | | | Ad Art 6.4 | | |
| - Place identification | 6.1-3 & 6.4 (a), 9.3, | 1.A.II.19.(c), 1.B (Note), 5 (a) & 6 (c), | | | | | |
| - Placement of | 10.2-5 & 10.7-8, 13.1-3, 13 bis 2-4, 15, 21 | 1.C. II.8 (c), 1.D.II.9, 1.E.II.3, 5 (a), (b), 6 (a), 8 (a) (i), (b) (i), 9 (b), 10 (a), 12 (a), 1.F.II.8 | | | | | |
| - Priority | 5.1 (b) (i), 10, 13 bis, 2 | I.B | | | Ad Annex 1.B. | | |
| - Prohibitory or restrictive | 5.1 (b) (ii), 11, 13.1, 13.3 | I.C | | | Ad Annex 1.C.II | | |
| - Regulatory | 5.1 (b), 8.4, 10-13 bis | | | | Ad Art. 13 bis, 2 | | |
| - Road identification | 17 | | | | | | |
| - Special regulation | 5.1 (b) (iv) | I.E | | | Ad Annex 1.E.II | | |
| - Variable message | 8.1 bis | | | | | | |
| - Zonal validity | 13.4-5, 13 bis 2 | I.E.II.8 | | | | | |
| Slippery road | | I.A.II.9 | | | | | |
| Snow chains compulsory | | I.D.II.9 | | | | | |

| Alphabetical index | Convention | | European Agreement | | Additional Protocol | |
|------------------------------------------------------------------------------------------------------------|--------------|--------------------|--------------------|--------------------|---------------------|-------|
| | Articles | Annexes / Sections | Articles | Annex / Sections | Articles | Annex |
| Special regulation signs | 5.1 (b) (iv) | I.E | | Ad Annex 1.E.II. | | |
| - Bus / Tramway stop | | 1.E.II.13 | | | | |
| - Characteristics | | 1.E.I | | | | |
| - Hospital | | 1.E.II.11 | | | | |
| - Lanes reserved for buses | | 1.E.II.2 | | | | |
| - One way | | 1.E.II.3 | | | | |
| - Parking | | 1.E.II.12 | | Ad Annex 1.E.II.3 | | |
| - Pedestrian crossing | | 1.E.II.10 | | Ad Annex 1.E.II.12 | | |
| - Preselection | | 1.E.II.4 | | Ad Annex 1.E.II.10 | | |
| - Regulation or danger warning applying to one or more traffic lanes | | 1.E.II.1 | | | | |
| - Signs having zonal validity | | 1.E.II.8 | | | | |
| - Signs indicating a stopping place in case of emergency or danger | | 1.E.II.14 | | | | |
| - Signs indicating the beginning and the end of a built-up area | | 1.E.II.7 | | Ad Annex 1.E.II.7 | | |
| - Signs notifying an entry to or an exit from a motorway | | 1.E.II.5 | | Ad Annex 1.E.II.5 | | |
| - Signs notifying an entry to or exit from a road on which the traffic rules are the same as on a motorway | | 1.E.II.6 | | Ad Annex 1.E.II.6 | | |
| - Signs notifying the entry to or exit from a tunnel where special rules apply | | 1.E.II.9 | | | | |

| Alphabetical index | Convention | | | European Agreement | | Additional Protocol | |
|------------------------------------------|--------------|--------------------|----------|--------------------|-------------------------------------------------------------------------------------------------------|---------------------|-----------------------------|
| | Articles | Annexes / Sections | Diagrams | Articles | Annex / Sections | Articles | Annex |
| Standing (vehicle) | 1 (i) (i) | 2.IV.D 1.C.II.9 | | | | | |
| - Definition - Regulations - Signs | | | | | | | |
| Steep ascent | | 1.A.II.3 | | | Ad Annex 1.A.II.3 | | |
| Stop | 27.1, 35.2 | 1.B.2 | | | Ad Annex 1.B.2 | | Ad Art. 27.1 |
| Stop lines | | 2.III.B | 18-21 | | | | Ad Annex. 2 (ex-8) III.B |
| Stripes | 28.1-2, 31.2 | | | | | | |
| Swing bridge (Flashing lights) | 23.1 (b) (i) | 1.A.II.5, 29 | | | | | |
| T | | | | | | | |
| Tactile signals | 24.5 | | | | | | |
| Track for riders on horseback | | 1.D.II.6 | | | | | |
| Traffic congestion | | 1.A.II.24 | | | | | |
| Traffic lights (signals) | 23, 24 | | | | Ad Art. 23.11 (additional para.), Ad Art 24.1(a) (ii), 2 & 3, Ad Art. 33.1 (a) (i) & 2 | | |

| Alphabetical index | Convention | | | European Agreement | | Additional Protocol | |
|---------------------------------------------------------|-----------------------------------------------|--------------------|----------|--------------------|------------------|---------------------|-------|
| | Articles | Annexes / Sections | Diagrams | Articles | Annex / Sections | Articles | Annex |
| - Flashing lights | 23.1 (b) | | | | | | |
| - For cyclists | 23.13 | | | | | | |
| - For pedestrians | 24 | | | | | | |
| - For traffic | 23 | | | | | | |
| - Non-flashing lights | 23.1 (a) | | | | | | |
| Trailers / Semi-trailers | | | | | | | |
| - Definition | 1 (o) | | | | | | |
| - Prohibition of entry | | 1.C.II.1 (c) | | | | | |
| Transverse markings (see Road markings) | | | | | | | |
| Tunnel | 13 <u>bis</u> 2 <u>bis</u> , 25 <u>bis</u> | | | | | | |
| Two-way traffic | | | | | | | |
| U | | | | | | | |
| Uneven road | | | | | | | |
| V | | | | | | | |
| Vehicles carrying dangerous goods (See Dangerous goods) | | | | | | | |

| Alphabetical index | Convention | | | European Agreement | | Additional Protocol | | |
|---------------------------|---------------------|--------------------|----------|--------------------|------------------|---------------------|------------------------------------------------------------------|----------|
| | Articles | Annexes / Sections | Diagrams | Articles | Annex / Sections | Articles | Annex | Diagrams |
| W Word markings | 28.1.3, 29.3 | 2.IV.C | 20 | | | | Ad Art. 29.2 (additional para), Ad Annex 2 (ex-8), IV.C | A-43-54 |
| Z Zigzag line | 28.3 | 2.IV.E (i) | 26 | | | | Ad Art 29.2, Ad Annex 2 (ex-8), IV.E (i) | A-55 |
| Zonal validity | 13.4-5, 13 bis 2 | 1.E.II.8 | | | | | | |

**VIENNA CONVENTION ON
ROAD TRAFFIC
1968**

PART I

CONVENTION ON ROAD TRAFFIC

DONE AT VIENNA ON 8 NOVEMBER 1968

(Consolidated version)*

* Including the amendments to the Convention which entered into force on 3 September 1993 (marked in the margin with a single line) and the amendments which entered into force on 28 March 2006 (marked in the margin with a double line).

CONVENTION ON ROAD TRAFFIC

The Contracting Parties,

Desiring to facilitate international road traffic and to increase road safety through the adoption of uniform traffic rules,

Have agreed upon the following provisions:

Chapter I

GENERAL PROVISIONS

ARTICLE 1

Definitions

For the purpose of this Convention the following expressions shall have the meanings hereby assigned to them:

(a) The “domestic legislation” of a Contracting Party means the entire body of national or local laws and regulations in force in the territory of that Contracting Party;

(b) A vehicle is said to be “in international traffic” in the territory of a State if:

- (i) It is owned by a natural or legal person normally resident outside that State;
- (ii) It is not registered in that State; and
- (iii) It is temporarily imported into that State;

provided, however, that a Contracting Party may refuse to regard as being “in international traffic” a vehicle which has remained in its territory for more than one year without a substantial interruption, the duration of which may be fixed by that Contracting Party.

A combination of vehicles is said to be “in international traffic” if at least one of the vehicles in the combination conforms to the above definition;

(c) “Built-up area” means an area with entries and exits specially signposted as such, or otherwise defined in domestic legislation;¹

(d) “Road” means the entire surface of any way or street open to public traffic;

(e) “Carriageway” means the part of a road normally used by vehicular traffic; a road may comprise several carriageways clearly separated from one another by, for example, a dividing strip or a difference of level;

¹ Definition completed in the Annex of the European Agreement (see subparagraph (c). Point 3).

(f) On carriageways where one or more side lanes or tracks are reserved for use by certain vehicles, "edge of the carriageway" means, for other road-users, the edge of the remainder of the carriageway;

(g) "Lane" means any one of the longitudinal strips into which the carriageway is divisible, whether or not defined by longitudinal road markings, which is wide enough for one moving line of motor vehicles other than motorcycles;

(g) bis "Cycle lane" means a part of a carriageway designated for cycles. A cycle lane is distinguished from the rest of the carriageway by longitudinal road markings;

(g) ter "Cycle track" means an independent road or part of a road designated for cycles, signposted as such. A cycle track is separated from other roads or other parts of the same road by structural means;

(h) "Intersection" means any level crossroad, junction or fork, including the open areas formed by such crossroads, junctions or forks;

(i) "Level-crossing" means any level intersection between a road and a railway or tramway track with its own track formation;

(j) "Motorway" means a road specially designed and built for motor traffic, which does not serve properties bordering on it, and which:

- (i) Is provided, except at special points or temporarily, with separate carriageways for the two directions of traffic, separated from each other either by a dividing strip not intended for traffic or, exceptionally, by other means;
- (ii) Does not cross at level with any road, railway or tramway track, or footpath; and
- (iii) Is specially signposted as a motorway;

(k) A vehicle is said to be:

- (i) "Standing" if it is stationary for the time needed to pick up or set down persons or to load or unload goods; and
- (ii) "Parked" if it is stationary for any reason other than the need to avoid interference with another road-user or collision with an obstruction or to comply with traffic regulations, and if the period during which the vehicle is stationary is not limited to the time needed to pick up or set down persons or goods;

Nevertheless, it shall be open to Contracting Parties to regard as "standing" any vehicle which is stationary within the meaning of subparagraph (ii) above for a period not exceeding that fixed by domestic legislation, and to regard as "parked" any vehicle which is stationary within the meaning of subparagraph (i) above for a period exceeding that fixed by domestic legislation;

(l) "Cycle" means any vehicle which has at least two wheels and is propelled solely by the muscular energy of the persons on that vehicle, in particular by means of pedals or hand-crank;

(m) "Moped" means any two-wheeled or three-wheeled vehicle which is fitted with an internal combustion engine having a cylinder capacity not exceeding 50 cc and a maximum design speed not exceeding 50 km (30 miles) per hour. Contracting Parties are free, however, not to regard as mopeds, under their domestic legislation, vehicles which do not have the characteristics of a cycle with respect to their use, in particular the characteristic that they can be propelled by pedals, or whose maximum design speed, whose mass, or certain of whose engine characteristics exceed certain limits. Nothing in this definition shall be construed as preventing Contracting Parties from treating mopeds exactly as cycles in applying the provisions of their domestic legislation regarding road traffic;

(n) "Motorcycle" means any two-wheeled vehicle, with or without a side-car, which is equipped with a propelling engine. Contracting Parties may also treat as motorcycles in their domestic legislation three-wheeled vehicles whose unladen mass does not exceed 400 kg. The term "motorcycle" does not include mopeds, although Contracting Parties may, provided they make a declaration to this effect in conformity with Article 54, paragraph 2, of this Convention, treat mopeds as motorcycles for the purposes of the Convention;²

(o) "Power-driven vehicle" means any self-propelled road vehicle, other than a moped in the territories of Contracting Parties which do not treat mopeds as motorcycles, and other than a rail-borne vehicle;

(p) "Motor vehicle" means any power-driven vehicle which is normally used for carrying persons or goods by road or for drawing, on the road, vehicles used for the carriage of persons or goods. This term embraces trolley-buses, that is to say, vehicles connected to an electric conductor and not rail-borne. It does not cover vehicles, such as agricultural tractors, which are only incidentally used for carrying persons or goods by road or for drawing, on the road, vehicles used for the carriage of persons or goods;

(q) "Trailer" means any vehicle designed to be drawn by a power-driven vehicle and includes semi-trailers;

(r) "Semi-trailer" means any trailer designed to be coupled to a motor vehicle in such a way that part of it rests on the motor vehicle and that a substantial part of its mass and of the mass of its load is borne by the motor vehicle;

(s) "Light trailer" means any trailer of a permissible maximum mass not exceeding 750 kg;

(t) "Combination of vehicles" means coupled vehicles which travel on the road as a unit;

(u) "Articulated vehicle" means a combination of vehicles comprising a motor vehicle and semi-trailer coupled to the motor vehicle;

(v) "Driver" means any person who drives a motor vehicle or other vehicle (including a cycle), or who guides cattle, singly or in herds, or flocks, or draught, pack or saddle animals on a road;

² Definition completed in the Annex of the European Agreement (see subparagraph (n), Point 3).

(w) “Permissible maximum mass” means the maximum mass of the laden vehicle declared permissible by the competent authority of the State in which the vehicle is registered;

(x) “Unladen mass” means the mass of the vehicle without crew, passengers or load, but with a full supply of fuel and with the tools which the vehicle normally carries;

(y) “Laden mass” means the actual mass of the vehicle as loaded, with the crew and passengers on board;

(z) “Direction of traffic” and “appropriate to the direction of traffic” mean the right-hand side if, under domestic legislation, the driver of a vehicle must allow an oncoming vehicle to pass on his left; otherwise these expressions mean the left-hand side;

(aa) The requirement that a driver shall “give way” to other vehicles means that he must not continue or resume his advance or manoeuvre if by so doing he might compel the drivers of other vehicles to change the direction or speed of their vehicle abruptly.

³ See footnote.

ARTICLE 2

Annexes to the Convention

The Annexes to this Convention, namely,

- Annex 1: Exceptions to the obligation to admit motor vehicles and trailers in international traffic;
- Annex 2: Registration number of motor vehicles and trailers in international traffic;
- Annex 3: Distinguishing sign of motor vehicles and trailers in international traffic;
- Annex 4: Identification marks of motor vehicles and trailers in international traffic;
- Annex 5: Technical conditions concerning motor vehicles and trailers;
- Annex 6: Domestic driving permit; and
- Annex 7: International driving permit;

are integral parts of this Convention.

³ Additional definitions introduced in the Annex of the European Agreement (see Point 3).

ARTICLE 3

Obligations of the Contracting Parties

1. (a) Contracting Parties shall take appropriate measures to ensure that the rules of the road in force in their territories conform in substance to the provisions of Chapter II of this Convention. Provided that the said rules are in no way incompatible with the said provisions:

- (i) The said rules need not reproduce any of the said provisions which are applicable to situations that do not arise in the territories of the Contracting Parties in question;
- (ii) The said rules may include provisions not contained in the said Chapter II.

(b) The provisions of this paragraph do not require Contracting Parties to provide penalties for any violation of those provisions of Chapter II which are reproduced in their rules of the road.

2. (a) Contracting Parties shall also take appropriate measures to ensure that the rules in force in their territories concerning the technical requirements to be satisfied by motor vehicles and trailers conform to the provisions of Annex 5 to this Convention; provided that they are in no way contrary to the safety principles governing the provisions of Annex 5, the said rules may contain provisions not contained in Annex 5. Contracting Parties shall also take appropriate measures to ensure that motor vehicles and trailers registered in their territories conform to the provisions of Annex 5 to this Convention when entering international traffic.

(b) The provisions of this paragraph do not impose any obligations on the Contracting Parties with respect to the rules in force in their territories concerning the technical requirements to be satisfied by power-driven vehicles which are not motor vehicles within the meaning of this Convention.

3. Subject to the exceptions provided for in Annex 1 to this Convention, Contracting Parties shall be bound to admit to their territories in international traffic motor vehicles and trailers which fulfil the conditions laid down in Chapter III of this Convention and whose drivers fulfil the conditions laid down in Chapter IV; they shall also be bound to recognize registration certificates issued in accordance with the provisions of Chapter III as *prima facie* evidence that the vehicles to which they refer fulfil the conditions laid down in the said Chapter III.

4. Measures which the Contracting Parties have taken or may take, either unilaterally or under bilateral or multilateral agreements, to admit to their territories in international traffic motor vehicles and trailers that do not satisfy all the conditions stated in Chapter III of this Convention and to recognize, in cases other than those specified in Chapter IV, the validity in their territories of driving permits issued in the territory of another Contracting Party shall be deemed to be in conformity with the object of this Convention.⁴

5. Contracting Parties shall be bound to admit to their territories in international traffic cycles and mopeds which fulfil the technical conditions laid down in Chapter V of this Convention and

⁴ See also Point 4 of the Annex of the European Agreement.

whose drivers have their normal residence in the territory of another Contracting Party. No Contracting Party shall require the drivers of cycles or mopeds in international traffic to hold a driving permit; however, Contracting Parties which have declared in conformity with Article 54, paragraph 2, of this Convention that they treat mopeds as motorcycles may require the drivers of mopeds in international traffic to hold a driving permit.

5 bis. Contracting Parties will take the necessary measures to ensure that road safety education be provided on a systematic and continuous basis, particularly in schools at all levels.

5 ter. Whenever driving instruction for learner drivers is provided by professional driving establishments, domestic legislation shall lay down minimum requirements concerning the curriculum and the qualifications of the personnel responsible for providing such instruction.

6. Contracting Parties undertake to communicate to any Contracting Party, which may so request, the information necessary to ascertain the identity of the person in whose name a power-driven vehicle, or a trailer coupled to such a vehicle, is registered in their territories if the request submitted shows that the vehicle has been involved in an accident or the driver of this vehicle has seriously infringed road traffic rules and is thereby liable to important penalties or disqualification from driving in the territory of the Contracting Party submitting the request.

7. Measures which the Contracting Parties have taken or may take either unilaterally or under bilateral or multilateral agreements to facilitate international road traffic by simplifying Customs, police, health and other similar formalities or to ensure that Customs offices and posts at a given frontier point have the same competence and are kept open during the same hours shall be deemed to be in conformity with the object of this Convention.

8. Nothing in paragraphs 3, 5 and 7 of this Article shall affect the right of a Contracting Party to make the admission to its territory in international traffic of motor vehicles, trailers, mopeds and cycles, and of their drivers and occupants, subject to its regulations concerning the commercial carriage of passengers and goods, to its regulations concerning insurance of drivers against third-party risks, to its Customs regulations and, in general, to its regulations on matters other than road traffic.

ARTICLE 4

Signs and signals

Contracting Parties to this Convention which are not Contracting Parties to the Convention on Road Signs and Signals opened for signature at Vienna on the same day as this Convention undertake that:

(a) All road signs, traffic light signals and road markings installed in their territory shall form a coherent system and shall be designed and placed in such a way as to be easily recognizable;

(b) The number of types of sign shall be limited and signs shall be placed only at points where they are deemed useful;

(c) Danger warning signs shall be installed at a sufficient distance from obstructions to give drivers adequate warning;

- (d) It shall be prohibited:
- (i) To affix to a sign, to its support or to any other traffic control device anything not related to the purpose of such sign or device; if, however, Contracting Parties or subdivisions thereof authorize a non-profit making association to install informative signs, they may permit the emblem of that association to appear on the sign or on its support provided this does not make it less easy to understand the sign;
 - (ii) To install any board, notice, marking or device which might be confused with signs or other traffic control devices, might render them less visible or effective, or might dazzle road-users or distract their attention in a way prejudicial to traffic safety;
 - (iii) To install on pavements and verges devices or equipment which might unnecessarily obstruct the movement of pedestrians, particularly elderly or disabled persons.

Chapter II

RULES OF THE ROAD

ARTICLE 5

Status of signs and signals

1. Road-users shall comply with the instructions conveyed by road signs, traffic light signals and road markings even if the said instructions appear to contradict other traffic regulations.
2. Instructions conveyed by traffic light signals shall take precedence over those conveyed by road signs regulating priority.

ARTICLE 6

Instructions given by authorized officials

1. When they are directing traffic, authorized officials shall be easily identifiable at a distance, at night as well as by day.
2. Road-users shall promptly obey all instructions given by authorized officials directing traffic.
3. It is recommended:⁵ that domestic legislation should provide that directions given by authorized officials directing traffic shall include the following:

(a) Arm raised upright; this gesture shall mean “attention, stop” for all road-users except drivers who are no longer able to stop with sufficient safety; further, if made at an intersection, this gesture shall not require drivers already on the intersection to stop;

⁵ See also Point 5 of the Annex of the European Agreement.

(b) Arm or arms outstretched horizontally; this gesture shall constitute a stop signal for all road-users approaching from any direction which would cut across that indicated by the outstretched arm or arms; after making this gesture, the authorized official directing traffic may lower his arm or arms; this gesture shall likewise constitute a stop signal for drivers in front of or behind the official;

(c) Swinging red light; this gesture shall constitute a stop signal for road-users towards whom the light is directed.

4. The instructions given by authorized officials directing traffic shall take precedence over those conveyed by road signs, traffic light signals and road markings, and over traffic regulations.

ARTICLE 7

General rules

1. Road-users shall avoid any behaviour likely to endanger or obstruct traffic, to endanger persons, or to cause damage to public or private property.

2. It is recommended that domestic legislation should provide that road-users shall not obstruct traffic or risk making it dangerous by throwing, depositing or leaving any object or substance on the road or by creating any other obstruction on the road. If road-users have been unable to avoid creating an obstruction or danger in that way, they shall take the necessary steps to remove it as soon as possible and, if they cannot remove it immediately, to warn other road-users of its presence.⁶

3. Drivers shall show extra care in relation to the most vulnerable road-users, such as pedestrians and cyclists and in particular children, elderly persons and the disabled.

4. Drivers shall take care that their vehicles do not inconvenience road-users or the occupants of properties bordering on the road, for example, by causing noise or raising dust or smoke where they can avoid doing so.

5. The wearing of safety belts is compulsory for drivers and passengers of motor vehicles, occupying seats equipped with such belts, save where exceptions are granted by domestic legislation.

⁷ See footnote.

ARTICLE 8

Drivers

1. Every moving vehicle or combination of vehicles shall have a driver.

2. It is recommended that domestic legislation should provide that pack, draught or saddle animals, and, except in such special areas as may be marked at the entry, cattle, singly or in herds, or flocks, shall have a driver.⁸

⁶ See also Point 6 of the Annex of the European Agreement.

⁷ Additional paragraph introduced in the Annex of the European Agreement (see Point 6).

⁸ See also Point 7 of the Annex of the European Agreement.

3. Every driver shall possess the necessary physical and mental ability and be in a fit physical and mental condition to drive.
4. Every driver of a power-driven vehicle shall possess the knowledge and skill necessary for driving the vehicle; however, this requirement shall not be a bar to driving practice by learner-drivers in conformity with domestic legislation.
5. Every driver shall at all times be able to control his vehicle or to guide his animals.⁹

¹⁰ See footnote.

6. A driver of a vehicle shall at all times minimize any activity other than driving. Domestic legislation should lay down rules on the use of phones by drivers of vehicles. In any case, legislation shall prohibit the use by a driver of a motor vehicle or moped of a hand-held phone while the vehicle is in motion.

ARTICLE 9

Flocks and herds

It is recommended that domestic legislation should provide that, save where exceptions are granted to facilitate their mass movement, flocks and herds should be divided into sections of moderate length spaced sufficiently far apart for the convenience of traffic.¹¹

ARTICLE 10

Position on the carriageway¹²

1. The direction of traffic shall be the same on all roads in a State except, where appropriate, on the roads used solely or principally by through traffic between two other States.

¹³ See footnote.

2. Animals moving along the carriageway shall be kept as close as possible to the edge of the carriageway appropriate to the direction of traffic.
3. Without prejudice to the provisions to the contrary of Article 7, paragraph 1, Article 11, paragraph 6, and to other provisions of this Convention to the contrary, every driver of a vehicle shall, to the extent permitted by circumstances, keep his vehicle near the edge of the carriageway appropriate to the direction of traffic. However, Contracting Parties or subdivisions thereof may lay down more precise rules concerning the position of goods vehicles on the carriageway.
4. Where a road comprises two or three carriageways, no driver shall take the carriageway situated on the side opposite to that appropriate to the direction of traffic.

⁹ See also Point 7 of the Annex of the European Agreement.

¹⁰ Additional paragraph introduced in the Annex of the European Agreement (see Point 7).

¹¹ See also Point 8 of the Annex of the European Agreement.

¹² See also Point 9 of the Annex of the European Agreement.

¹³ Additional paragraph introduced in the Annex of the European Agreement (see Point 9).

5. (a) On two-way carriageways having four or more lanes, no driver shall take the lanes situated entirely on the half of the carriageway opposite to the side appropriate to the direction of traffic.

(b) On two-way carriageways having three lanes, no driver shall take the lane situated at the edge of the carriageway opposite to that appropriate to the direction of traffic.

6. Without prejudice to the provisions of Article 11 and when an additional lane is indicated by a sign, drivers of vehicles moving slowly shall use that lane.

ARTICLE 11

Overtaking and movement of traffic in lines

1. (a) Drivers overtaking shall do so on the side opposite to that appropriate to the direction of traffic.

(b) However drivers shall overtake on the side appropriate to the direction of traffic if the driver to be overtaken has signalled his intention to turn to the side of the carriageway opposite to that appropriate to the direction of traffic and has moved his vehicle or animals over towards that side in order to turn to that side for the purpose of taking another road, to enter a property bordering on the road, or to stop on that side.

(c) Domestic legislation may authorize cyclists and moped riders to pass stationary vehicles or vehicles moving at a low speed other than cycles or mopeds on the side which corresponds to the direction of traffic provided that sufficient space is available.

2. Before overtaking, every driver shall, without prejudice to the provisions of Article 7, paragraph 1, or to those of Article 14, of this Convention, make sure:

(a) That no driver who is following him has begun to overtake him;

(b) That the driver ahead of him in the same lane has not given warning of his intention to overtake another;

(c) That he can do it without endangering or interfering with the oncoming traffic making sure in particular that the lane which he will enter is free over a sufficient distance and that the relative speed of the two vehicles allows overtaking within a sufficiently short time; and

(d) That, except when using a lane closed to oncoming traffic, he will be able, without inconvenience to the road-user or road-users overtaken, to resume the position prescribed in Article 10, paragraph 3, of this Convention.

3. In pursuance of the provisions of paragraph 2 of this Article, overtaking on two-way carriageways is in particular prohibited when approaching the crest of a hill and, if visibility is inadequate, on bends, unless there are at these points lanes defined by longitudinal road markings and overtaking is carried out without leaving the lanes marked as closed to oncoming traffic.

4. When overtaking, a driver shall give the road-user or road-users overtaken a sufficiently wide berth.

5. (a) On carriageways with at least two lanes reserved for traffic moving in the direction in which he is proceeding, a driver who should be obliged, immediately or shortly after moving back to the position prescribed by Article 10, paragraph 3, of this Convention, to overtake again may, in order to perform that manoeuvre, and provided he makes sure he can do so without undue inconvenience to the drivers of faster vehicles approaching from behind, remain in the lane he has occupied for the first overtaking manoeuvre.

(b) However, Contracting Parties or subdivisions thereof shall be free not to apply the provisions of this paragraph to the drivers of cycles, mopeds, motorcycles and vehicles which are not motor vehicles within the meaning of this Convention, or to the drivers of motor vehicles whose permissible maximum mass exceeds 3,500 kg or whose maximum speed, by design, cannot exceed 40 km (25 miles) per hour.¹⁴

6. Where the provisions of subparagraph 5 (a) of this Article are applicable and the density of traffic is such that vehicles not only occupy the entire width of the carriageway reserved for traffic taking the direction in which they are moving but also are moving only at a speed which is governed by that of the vehicle preceding them in the line:

(a) Without prejudice to the provisions of paragraph 9 of this Article, the movement of the vehicles in one line at a higher speed than that of those in another shall not be deemed to constitute overtaking within the meaning of this Article;

(b) A driver not in the lane nearest to the edge of the carriageway appropriate to the direction of traffic may change lanes only in order to prepare to turn right or left or to park; however, this requirement shall not apply to changes of lane effected by drivers in accordance with domestic legislation resulting from the application of the provisions of paragraph 5 (b) of this Article.¹⁵

7. When moving in lines as described in paragraphs 5 and 6 of this Article, drivers are forbidden, if the lanes are indicated on the carriageway by longitudinal markings, to straddle these markings.

8. Without prejudice to the provisions of paragraph 2 of this Article and to other restrictions which Contracting Parties or subdivisions thereof may lay down concerning overtaking at intersections and at level-crossings, no driver of a vehicle shall overtake a vehicle other than a two-wheeled cycle, a two-wheeled moped or a two-wheeled motorcycle without side-car:

- (a) Immediately before or on an intersection other than a roundabout, except:
- (i) In the case provided for in paragraph 1 (b) of this Article;
 - (ii) Where the road on which overtaking takes place has priority at the intersection;
 - (iii) Where traffic is directed at the intersection by an authorized official or by traffic light signals;

¹⁴ See also Point 10 of the Annex of the European Agreement.

¹⁵ See also Point 10 of the Annex of the European Agreement.

(b) Immediately before or on a level-crossing not equipped with gates or half-gates, provided however that Contracting Parties or subdivisions thereof shall be free to permit such overtaking at a level-crossing where road traffic is regulated by traffic light signals incorporating a positive signal authorizing vehicles to proceed.¹⁶

9. A vehicle shall not overtake another vehicle which is approaching a pedestrian crossing marked on the carriageway or signposted as such, or which is stopped immediately before the crossing, otherwise than at a speed low enough to enable it to stop immediately if a pedestrian is on the crossing. Nothing in this paragraph shall be construed as preventing Contracting Parties or subdivisions thereof from prohibiting overtaking within a prescribed distance from a pedestrian crossing, or from imposing stricter requirements on a driver of a vehicle proposing to overtake another vehicle stopped immediately before such a crossing.

10. A driver who perceives that a driver following him wishes to overtake him shall, except in the case provided for in Article 16, paragraph 1 (b) of this Convention, keep close to the edge of the carriageway appropriate to the direction of traffic and refrain from accelerating. If, owing to the narrowness, profile or condition of the carriageway, taken in conjunction with the density of oncoming traffic, a vehicle which is slow or bulky or is required to observe a speed limit cannot be easily and safely overtaken, the driver of such vehicle shall slow down and if necessary pull in to the side as soon as possible in order to allow vehicles following him to overtake.

11.¹⁷ (a) Contracting Parties or subdivisions thereof may, on one-way carriageways and on two-way carriageways where at least two lanes in built-up areas and three lanes outside built-up areas are reserved for traffic in the same direction and are indicated by longitudinal markings:

- (i) Allow vehicles in one lane to overtake on the side appropriate to the direction of traffic vehicles in another lane; and
- (ii) Make inapplicable the provisions of Article 10, paragraph 3, of this Convention;

provided that there are adequate restrictions on the possibility of changing lanes;

(b) In the case referred to in subparagraph (a) of this paragraph, without prejudice to the provisions of paragraph 9 of this Article, the manner of driving provided for shall not be deemed to constitute overtaking within the meaning of this Convention.

ARTICLE 12

Passing of oncoming traffic

1. When passing oncoming traffic, a driver shall leave sufficient lateral space and, if necessary, move close to the edge of the carriageway appropriate to the direction of traffic. If in so doing he finds his progress impeded by an obstruction or by the presence of other road-users, he shall slow down and if necessary stop to allow the oncoming road-user or road-users to pass.

2. On mountain roads and steep roads with characteristics similar to those of mountain roads, where the passing of oncoming traffic is impossible or difficult, it is the driver of the vehicle

¹⁶ See also Point 10 of the Annex of the European Agreement.

¹⁷ See also Point 10 of the Annex of the European Agreement.

travelling downhill who should pull in to the side of the road in order to allow any vehicle proceeding uphill to pass, except where the arrangement of lay-bys to enable vehicles to pull in to the side of the road is such that, having regard to the speed and position of the vehicles, the vehicle proceeding uphill has a lay-by ahead of it and the need for one of the vehicles to reverse could be avoided if the vehicle proceeding uphill pulled in to that lay-by. Where one of the two vehicles which are about to pass is obliged to reverse in order to make passing possible, this manoeuvre shall be performed by the driver of the vehicle proceeding downhill unless it can manifestly be more easily performed by the driver of the vehicle proceeding uphill. However, Contracting Parties or subdivisions thereof may prescribe for certain vehicles or certain roads or sections of roads special rules differing from those laid down in this paragraph.¹⁸

ARTICLE 13

Speed and distance between vehicles

1. Every driver of a vehicle shall in all circumstances have his vehicle under control so as to be able to exercise due and proper care and to be at all times in a position to perform all manoeuvres required of him. He shall, when adjusting the speed of his vehicle, pay constant regard to the circumstances, in particular the lie of the land, the state of the road, the condition and load of his vehicle, the weather conditions and the density of traffic, so as to be able to stop his vehicle within his range of forward vision and short of any foreseeable obstruction. He shall slow down and if necessary stop whenever circumstances so require, and particularly when visibility is not good.¹⁹

2. Domestic legislation shall establish maximum speed limits for all roads. Domestic legislation shall also determine special speed limits applicable to certain categories of vehicles presenting a special danger, in particular by reason of their mass or their load. They may establish similar provisions for certain categories of drivers, in particular for new drivers.

3. The provisions set out in the first sentence of paragraph 2 may not apply to drivers of priority vehicles referred to in article 34, paragraph 2, or vehicles treated as such in domestic legislation.

4. No driver shall impede the normal progress of other vehicles by travelling abnormally slowly without proper cause.

5. The driver of a vehicle moving behind another vehicle shall keep at a sufficient distance from that other vehicle to avoid collision if the vehicle in front should suddenly slow down or stop.

[*ex paragraph 5 deleted*]

6.²⁰ Outside built-up areas, in order to facilitate overtaking, drivers of vehicles or combinations of vehicles of more than 3,500 kg permissible maximum mass, or of more than 10 m overall length, shall, except when they are overtaking or preparing to overtake, keep at such distance from power-driven vehicles ahead of them that other vehicles overtaking them can without danger move into the space in front of the overtaken vehicle. However, this provision shall not apply in very dense traffic or in circumstances where overtaking is prohibited. In addition:

¹⁸ See also Point 11 of the Annex of the European Agreement.

¹⁹ See also Point 12 of the Annex of the European Agreement.

²⁰ See also Point 12 of the Annex of the European Agreement.

(a) The competent authorities may exempt certain conveyances of vehicles from this provision, or may similarly make it inapplicable on roads where two lanes are allotted to traffic in the direction concerned;

(b) Contracting Parties and subdivisions thereof may prescribe different figures from those given in this paragraph with respect to the vehicle characteristics concerned.

ARTICLE 14

General requirements governing manoeuvres

1. Any driver wishing to perform a manoeuvre such as pulling out of or into a line of parked vehicles, moving over to the right or to the left on the carriageway, or turning left or right into another road or into a property bordering on the road, shall first make sure that he can do so without risk of endangering other road-users travelling behind or ahead of him or about to pass him, having regard to their position, direction and speed.²¹

2. Any driver wishing to make a U-turn or to reverse shall first make sure that he can do so without endangering or impeding other road-users.

3. Before turning or before a manoeuvre which involves moving laterally, the driver shall give clear and sufficient warning of his intention by means of the direction-indicator or direction-indicators on his vehicle, or, failing this, by giving if possible an appropriate signal with his arm. The warning given by the direction-indicator or direction-indicators shall continue to be given throughout the manoeuvre and shall cease as soon as the manoeuvre is completed.

ARTICLE 15

Special regulations relating to regular public-transport service vehicles

It is recommended²² that domestic legislation should provide that in built-up areas, in order to facilitate the movement of regular public-transport service vehicles, the drivers of other vehicles shall, subject to the provisions of Article 17, paragraph 1, of this Convention, slow down and if necessary stop in order to allow the public-transport vehicles to perform the manoeuvre required for moving off from stops marked as such. The provisions thus laid down by Contracting Parties or subdivisions thereof shall in no way affect the duty incumbent on drivers of public-transport vehicles to take, after having given warning by means of their direction-indicators of their intention to move off, the precautions necessary to avoid any risk of accident.

ARTICLE 16

Change of direction

1. Before turning right or left for the purpose of entering another road or entering a property bordering on the road, a driver shall, without prejudice to the provisions of Article 7, paragraph 1, and of Article 14, of this Convention:

²¹ See also Point 13 of the Annex of the European Agreement.

²² See also Point 14 of the Annex of the European Agreement.

(a) If he wishes to turn off on the side appropriate to the direction of traffic, keep as close as possible to the edge of the carriageway appropriate to that direction and make as tight a turn as possible;

(b) If he wishes to turn off on the other side, and subject to such other provisions as Contracting Parties or subdivisions thereof may enact for cycles and mopeds enabling them to change direction, for instance by crossing the intersection in two separate stages, move as closely as possible to the centreline of the carriageway if it is a two-way carriageway or to the edge opposite to the side appropriate to the direction of traffic if it is a one-way carriageway and, if he wishes to enter another two-way road, make his turn so as to enter the carriageway of such other road on the side appropriate to the direction of traffic.

2. While changing direction, the driver shall, without prejudice to the provisions of Article 21 of this Convention regarding pedestrians, allow road users to pass on the carriageway, or on other parts of the same road he is preparing to leave.

ARTICLE 17

Slowing down

1. No driver of a vehicle shall brake abruptly unless it is necessary to do so for safety reasons.
2. Every driver intending to slow down to an appreciable extent shall, except where his slowing down is in response to an imminent danger, first make sure that he can do so without danger or undue inconvenience to other drivers. He shall also, unless he has made sure that there is no vehicle following him or that any following vehicle is a long way behind, give clear and timely warning of his intention by making an appropriate signal with his arm. However, this provision shall not apply if warning of slowing down is given by the vehicle's stop lights, referred to in Annex 5, paragraph 31, of this Convention.

ARTICLE 18

Intersections and obligation to give way

1. Every driver approaching an intersection shall exercise such extra care as may be appropriate to local conditions. Drivers of vehicles shall, in particular, drive at such a speed as to be able to stop to allow vehicles having the right of way to pass.
2. Every driver emerging from a path or an earth-track (dirt road) on to a road other than a path or an earth-track shall give way to vehicles travelling on that road. For the purposes of this Article the terms "path" and "earth-track" (dirt road) may be defined in domestic legislation.
3. Every driver emerging on to a road from a property bordering thereon shall give way to vehicles travelling on that road.²³

²³ See also Point 15 of the Annex of the European Agreement.

4. Subject to the provisions of paragraph 7 of this Article:

(a) In States where traffic keeps to the right the driver of a vehicle shall give way, at intersections other than those specified in paragraph 2 of this Article and in Article 25, paragraphs 2 and 4 of this Convention, to vehicles approaching from his right;

(b) Contracting Parties or subdivisions thereof in whose territories traffic keeps to the left shall be free to regulate the right of way at intersections as they see fit.²⁴

5. Even if traffic light signals authorize him to do so, a driver shall not enter an intersection if the density of traffic is such that he will probably be obliged to stop on the intersection, thereby obstructing or preventing the passage of cross traffic.

6. A driver who has entered an intersection where traffic is regulated by traffic light signals may clear the intersection without waiting for the way to be opened in the direction in which he wishes to proceed, provided that this does not impede the progress of other road-users moving in the open direction.

7. *[Words deleted]* Drivers of vehicles not moving on rails shall give way to rail-borne vehicles.

²⁵ See footnote.

ARTICLE 19

Level-crossings

Road-users shall exercise extra care in approaching and traversing level-crossings. In particular:

(a) Every driver of a vehicle shall drive at a moderate speed;

(b) Without prejudice to the obligation to obey an instruction to stop given by a light signal or a sound signal, no road-user shall enter a level-crossing at which the gates or half-gates are across the road or in process of being placed across the road, or at which the half-gates are in process of being raised;

(c) If a level-crossing is not equipped with gates, half-gates or light signals, no road-user shall enter it without making sure that no rail-borne vehicle is approaching;

(d) No driver shall enter a level-crossing without first ascertaining that he may not be obliged to stop on it;

(e) No road-user shall linger while traversing a level crossing; if a vehicle is compelled to stop, its driver shall endeavour to move it off the track, and, if he is unable to do so, immediately do everything he can to ensure that the drivers of rail-borne vehicles are warned of the danger in time.

²⁴ See also Point 15 of the Annex of the European Agreement.

²⁵ Additional paragraph introduced in the Annex of the European Agreement (see Point 15).

ARTICLE 20

Rules applicable to pedestrians

1. Contracting Parties or subdivisions thereof shall be free not to enforce the provisions of this Article except in cases where pedestrian traffic on the carriageway would be dangerous or would obstruct vehicular traffic.²⁶

2. If, at the side of the carriageway, there are pavements (sidewalks) or suitable verges for pedestrians, pedestrians shall use them. Nevertheless, if they take the necessary precautions:

(a) Pedestrians pushing or carrying bulky objects may use the carriageway if they would seriously inconvenience other pedestrians by walking on the pavement (sidewalk) or verge;

(b) Groups of pedestrians led by a person in charge or forming a procession may walk on the carriageway.

²⁷ See footnote.

3. If it is not possible to use pavements (sidewalks) or verges, or if none is provided, pedestrians may walk on the carriageway; where there is a cycle track and the density of traffic so permits, they may walk on the cycle track, but shall not obstruct cycle and moped traffic in doing so.

4. Pedestrians walking on the carriageway in accordance with paragraphs 2 and 3 of this Article shall keep as close as possible to the edge of the carriageway.²⁸

5. It is recommended that domestic legislation should provide as follows: pedestrians walking on the carriageway shall keep to the side opposite to that appropriate to the direction of traffic except where to do so places them in danger. However, persons pushing a cycle, a moped or a motorcycle, and groups of pedestrians led by a person in charge or forming a procession shall in all cases keep to the side of the carriageway appropriate to the direction of traffic. Unless they form a procession, pedestrians walking on the carriageway shall, by night or when visibility is poor and, by day, if the density of vehicular traffic so requires, walk in single file wherever possible.²⁹

6. (a) Pedestrians wishing to cross a carriageway shall not step on to it without exercising care; they shall use a pedestrian crossing whenever there is one nearby;

(b) In order to cross the carriageway at a pedestrian crossing signposted as such or indicated by markings on the carriageway:

(i) If the crossing is equipped with light signals for pedestrians, the latter shall obey the instructions given by such lights;

²⁶ See also Point 16 of the Annex of the European Agreement.

²⁷ Additional paragraph introduced in the Annex of the European Agreement (see Point 16).

²⁸ See also Point 16 of the Annex of the European Agreement.

²⁹ See also Point 16 of the Annex of the European Agreement.

- (ii) If the crossing is not equipped with such lights, but vehicular traffic is regulated by traffic light signals or by an authorized official, pedestrians shall not step onto the carriageway while the traffic light signal or the signal given by the authorized official indicates that vehicles may proceed along it;
- (iii) At other pedestrian crossings, pedestrians shall not step on to the carriageway without taking the distance and speed of approaching vehicles into account.

(c) In order to cross the carriageway elsewhere than at a pedestrian crossing signposted as such or indicated by markings on the carriageway, pedestrians shall not step on to the carriageway without first making sure that they can do so without impeding vehicular traffic.³⁰

(d) Once they have started to cross a carriageway, pedestrians shall not take an unnecessarily long route, and shall not linger or stop on the carriageway unnecessarily.

7. However, Contracting Parties or subdivisions thereof may impose stricter requirements on pedestrians crossing the carriageway.

ARTICLE 21

Behaviour of drivers towards pedestrians

1. Every driver shall avoid behaviour likely to endanger pedestrians.

2. Without prejudice to the provisions of Article 7, paragraph 1, Article 11, paragraph 9, and Article 13, paragraph 1, of this Convention, where there is on the carriageway a pedestrian crossing signposted as such or indicated by markings on the carriageway:

(a) If vehicular traffic is regulated at that crossing by traffic light signals or by an authorized official, drivers forbidden to proceed shall stop short of the crossing or the transverse markings preceding it and, when they are permitted to proceed, shall not prevent or obstruct the passage of pedestrians who have stepped on to it; drivers turning into another road at the entrance to which there is a pedestrian crossing shall do so slowly and give way, if necessary stopping for this purpose, to pedestrians already using, or about to use, the crossing;

(b) If vehicular traffic is not regulated at that crossing by traffic light signals or by an authorized official, drivers shall approach the crossing only at a speed low enough not to endanger pedestrians using, or about to use, it; if necessary, they shall stop to allow such pedestrians to cross.

3. No provision of this Article shall be construed as preventing Contracting Parties or subdivisions thereof from:³¹

³⁰ See also Point 16 of the Annex of the European Agreement.

³¹ See also Point 17 of the Annex of the European Agreement.

Requiring drivers of vehicles to stop in all cases when pedestrians are using, or about to use, a pedestrian crossing signposted as such or indicated by markings on the carriageway in the conditions laid down in Article 20 of this Convention, or

Prohibiting them from preventing or obstructing the passage of pedestrians who are crossing the carriageway at or very near an intersection even if there is at that point no pedestrian crossing signposted as such or indicated by markings on the carriageway.

4. Drivers intending to overtake, on the side appropriate to the direction of traffic, a public transport vehicle at a stop marked as such shall slow down and if necessary stop to allow passengers to board or alight from that vehicle.

³² See footnote.

ARTICLE 22

Islands on the carriageway

Without prejudice to the provisions of Article 10 of this Convention, a driver may pass to the left or to the right of islands, posts and other devices set up on the carriageway on which he is travelling, except in the following cases:

(a) Where the side on which the island, post or device shall be passed is indicated by a sign;

(b) Where the island, post or device is on the centre-line of a two-way carriageway; in this case the driver shall keep to the side of the island, post or device corresponding to the direction of traffic.

ARTICLE 23

Standing and parking

1. Outside built-up areas, standing or parked vehicles and halted animals shall so far as possible be stationed elsewhere than on the carriageway. Both in and outside built-up areas they shall not be stationed on cycle tracks, cycle lanes, bus lanes, tracks for horseback riders, footpaths, pavements or on verges specially provided for pedestrian traffic, save where applicable domestic legislation so permits.

2. (a) Animals halted and vehicles standing or parked on the carriageway shall be kept as close as possible to the edge of the carriageway. A driver shall not stand or park his vehicle on a carriageway save on the side appropriate, for him, to the direction of traffic; nevertheless, standing or parking on the other side shall be permitted where standing or parking on the side appropriate to the direction of traffic is prevented by the presence of rail tracks. Moreover, Contracting Parties or subdivisions thereof may:

³² Additional paragraphs introduced in the Annex of the European Agreement (see Point 17).

- (i) Refrain from prohibiting standing and parking on one side or the other in certain conditions, for instance where standing on the side appropriate to the direction of traffic is prohibited by road signs;
- (ii) On one-way carriageways, authorize standing and parking on the other side as well as or instead of on the side appropriate to the direction of traffic;
- (iii) Authorize standing and parking in the middle of the carriageway at places specially marked;

(b) Save where domestic legislation provides otherwise, vehicles other than two-wheeled cycles, two-wheeled mopeds and two-wheeled motorcycles without side-car shall not stand or be parked two abreast on the carriageway. Standing or parked vehicles shall, unless the layout of the area permits otherwise, be placed parallel to the edge of the carriageway.³³

3. (a) The standing or parking of a vehicle on the carriageway shall be prohibited:³⁴
- (i) On pedestrian crossings, on crossings for cyclists, and on level-crossings;
 - (ii) On tramway or railway tracks on a road or so close to such tracks that the movement of trams or trains might be impeded, and also, subject to the possibility for Contracting Parties or subdivisions thereof to provide otherwise, on pavements and cycle tracks;

³⁵ See footnote.

(b) The standing or parking of a vehicle at any point where it would constitute a danger shall be prohibited, more particularly:

- (i) Save in such spaces as may be specially marked, under flyovers and in tunnels;
- (ii) On the carriageway, close to the crests of hills, and on bends where visibility is not sufficient for the vehicle to be overtaken in complete safety, having regard to the speed of vehicles on the section of the road in question;
- (iii) On a carriageway beside a longitudinal road marking, where subparagraph (b) (ii) of this paragraph does not apply but the width of the carriageway between the marking and the vehicle is less than 3 m and the marking is such that vehicles approaching it on the same side are forbidden to cross it;
- (iv) At any place where the vehicle would conceal road signs or traffic light signals from the view of road-users;
- (v) On an additional lane indicated by a sign for slowly moving vehicles;

³³ See also Point 18 of the Annex of the European Agreement.

³⁴ See also Point 18 of the Annex of the European Agreement.

³⁵ Additional text introduced in the Annex of the European Agreement (see Point 18).

- (c) The parking of a vehicle on the carriageway shall be prohibited:
- (i) On approaches to level-crossings, to intersections and to bus, trolley-bus or rail vehicle stops; within the distances prescribed by domestic legislation;³⁶
 - (ii) In front of vehicle entries to properties;
 - (iii) At any point where the parked vehicle would prevent access to another vehicle properly parked or prevent such other vehicle from moving out;
 - (iv) On the central carriageway of three-carriageway roads and, outside built-up areas, on the carriageways of roads marked as priority roads by appropriate signs.
 - (v) *[deleted]*

4. A driver shall not leave his vehicle or his animals without having taken all suitable precautions to avoid any accident and, in the case of a motor vehicle, to prevent its unauthorized use.

5.³⁷ It is recommended that domestic legislation should provide as follows: every power-driven vehicle other than a two-wheeled moped or a two-wheeled motorcycle without side-car, and every trailer coupled or uncoupled shall when stationary on the carriageway outside a built-up area be signalled to approaching drivers at a sufficient distance by means of at least one appropriate device placed at the most suitable point to give them adequate advance warning:

(a) If the vehicle is stationary at night on the carriageway in circumstances such that approaching drivers cannot be aware of the obstacle which the vehicle constitutes;

(b) If the driver, in other cases, has been compelled to halt his vehicle at a place where standing is prohibited.

6. Nothing in this Article shall be construed as preventing Contracting Parties or subdivisions thereof from introducing other provisions on parking and standing or from making individual provisions for the standing and parking of cycles and mopeds.

³⁸ See footnote.

ARTICLE 24

Opening of doors

It shall be prohibited to open the door of a vehicle, to leave it open, or to alight from the vehicle without having made sure that to do so cannot endanger other road-users.

³⁶ See also Point 18 of the Annex of the European Agreement.

³⁷ See also Point 18 of the Annex of the European Agreement.

³⁸ Additional paragraph introduced in the Annex of the European Agreement (see Point 18).

ARTICLE 25

Motorways and similar roads

1.³⁹ On motorways and, if so provided in domestic legislation, on special approach roads to and exit roads from motorways:

(a) The use of the road shall be prohibited to pedestrians, animals, cycles, mopeds unless they are treated as motorcycles, and all vehicles other than motor vehicles and their trailers, and to motor vehicles or motor-vehicle trailers which are incapable, by virtue of their design, of attaining on a flat road a speed specified by domestic legislation;

(b) Drivers shall be forbidden:

- (i) To have their vehicles standing or parked elsewhere than at marked parking sites; if a vehicle is compelled to stop, its driver shall endeavour to move it off the carriageway and also off the flush verge and, if he is unable to do so, immediately signal the presence of the vehicle at a distance so as to warn approaching drivers in time;
- (ii) To make U-turns, to travel in reverse, and to drive on to the central dividing strip, including the crossovers linking the two carriageways.

⁴⁰ See footnote.

2. Drivers emerging on to a motorway shall give way to vehicles travelling on it. If there is an acceleration lane, they shall use it.

3. A driver leaving a motorway shall move into the traffic lane appropriate to the motorway exit in good time and enter the deceleration lane, if there is one, as soon as he can.

⁴¹ See footnote.

4. For the purpose of the application of paragraphs 1, 2 and 3 of this Article, other roads reserved for motor vehicle traffic, duly signposted as such and not affording access to or from properties alongside, shall be treated as motorways.⁴²

ARTICLE 25 bisSpecial regulations for tunnels indicated by special road signs

In tunnels indicated by the special road signs, the following rules shall apply:

1. All drivers are forbidden:

³⁹ See also Point 19 of the Annex of the European Agreement.

⁴⁰ Additional paragraph introduced in the Annex of the European Agreement (see Point 19).

⁴¹ Additional paragraph introduced in the Annex of the European Agreement (see Point 19).

⁴² See also Point 19 of the Annex of the European Agreement.

- (a) to reverse;
 - (b) to make a U-turn;
 - (c) *[deleted]*
2. Even if the tunnel is lit, all drivers must switch on the driving or passing lamps.
 3. Drivers are permitted to stop or park a vehicle only in case of emergency or danger. In doing so, they must, where possible, use the places specially indicated.
 4. In case of a prolonged stoppage the driver must switch off the engine.

ARTICLE 26

Special rules applicable to processions and
handicapped persons

1. It shall be prohibited for road-users to cut across troop columns, files of schoolchildren accompanied by a person in charge, and other processions.
2. Handicapped persons travelling in invalid chairs propelled by themselves or moving at a walking pace may use pavements (sidewalks) and suitable verges.

ARTICLE 27

Special rules applicable to cyclists, moped drivers
and motorcyclists

1. Notwithstanding the provisions of Article 10, paragraph 3, of this Convention, Contracting Parties or subdivisions thereof shall be free not to prohibit cyclists from travelling two or more abreast.
2. It shall be prohibited for cyclists to ride without holding the handlebars with at least one hand, to allow themselves to be towed by another vehicle, or to carry, tow or push objects which hamper their cycling or endanger other road-users. The same provisions shall apply to moped drivers and motorcyclists; in addition, however, moped drivers and motorcyclists shall hold the handlebars with both hands except when signalling the manoeuvre described in Article 14, paragraph 3, of this Convention.⁴³
3. It shall be prohibited for cyclists and moped drivers to carry passengers on their vehicle; however, Contracting Parties or subdivisions thereof may authorize exceptions to this provision and, in particular, authorize the transport of passengers on such additional saddle or saddles as may be fitted on the vehicle. Motorcyclists shall not be permitted to carry passengers except in the sidecar, if there is one, and on the additional saddle (pillion), if any, fitted behind the driver.
4. Where cycle lanes or cycle tracks exist, Contracting Parties or subdivisions thereof may forbid cyclists to use the rest of the carriageway. In the same circumstances, they may authorize moped drivers to use the cycle lane or cycle track and, if they consider it advisable, prohibit them

⁴³ See also Point 20 of the Annex of the European Agreement.

from using the rest of the carriageway. Domestic legislation shall specify under what conditions other road users may use the cycle lane or cycle track or cross them, maintaining cyclists' safety at all times.⁴⁴

⁴⁵ See footnote.

⁴⁶ See footnote.

ARTICLE 28

Audible and luminous warnings

1. Audible warning devices may be used only:
 - (a) To give due warning with a view to avoiding an accident;
 - (b) Outside built-up areas when it is desirable to warn a driver that he is about to be overtaken.

The sounds emitted by audible warning devices shall not be prolonged more than necessary.

2. Motor-vehicle drivers may give the luminous warnings specified in Article 32, paragraph 3, of this Convention, instead of audible warnings, between nightfall and dawn. They may also do so in daylight hours for the purpose indicated in paragraph 1 (b) of this Article, if to do so is more appropriate in the prevailing circumstances.

3. Contracting Parties or subdivisions thereof may authorize the use of luminous warnings in built-up areas also for the purpose referred to in paragraph 1 (b) of this Article.

ARTICLE 29

Rail-borne vehicles

1. Where a railway uses a carriageway, every road-user shall, on the approach of a tram or other rail-borne vehicle clear the track as soon as possible to allow the rail-borne vehicle to pass.
2. Contracting Parties or subdivisions thereof may adopt special rules, differing from those laid down in this Chapter, for the movement of rail-borne vehicles on the road and for passing or overtaking such vehicles. However, Contracting Parties or subdivisions thereof may not adopt provisions which conflict with those of Article 18, paragraph 7, of this Convention.⁴⁷

⁴⁸ See footnote.

⁴⁴ See also Point 20 of the Annex of the European Agreement.

⁴⁵ Additional paragraph introduced in the Annex of the European Agreement (see Point 20).

⁴⁶ Additional articles (Articles 27 bis to 27 quarter) introduced in the Annex of the European Agreement (see Point 20 bis).

⁴⁷ See also Point 21 of the Annex of the European Agreement.

⁴⁸ Additional paragraph introduced in the Annex of the European Agreement (see Point 21).

ARTICLE 30

Loading of vehicles

1. If a permissible maximum mass is laid down for a vehicle, the laden mass of the vehicle shall never exceed the permissible maximum mass.
2. Every load on a vehicle shall be so arranged and, if necessary, stowed as to prevent it from:
 - (a) Endangering persons or causing damage to public or private property, more particularly by trailing on or falling on to the road;
 - (b) Obstructing the driver's view or impairing the stability or driving of the vehicle;
 - (c) Causing noise, raising dust, or creating any other nuisance which can be avoided;
 - (d) Masking lights, including stop lights and direction-indicators, reflex reflectors, registration numbers and the distinguishing sign of the State of registration with which, under this Convention or under domestic legislation, the vehicle is required to be equipped, or masking signals given by arm in accordance with Article 14, paragraph 3, or Article 17, paragraph 2, of this Convention.
3. All accessories, such as cables, chains and sheets, used to secure or protect the load shall be drawn tight around the load and be firmly fastened. All accessories used to protect the load shall satisfy the requirements laid down for the load in paragraph 2 of this Article.
- 4.⁴⁹ Loads projecting beyond the front, rear or sides of the vehicle shall be clearly marked in all cases where their projection might not be noticed by the drivers of other vehicles; at night, a white light and a white reflecting device shall be used for such marking at the front and a red light and a red reflecting device at the rear. More particularly, on power-driven vehicles:
 - (a) Loads projecting more than 1 m beyond the front or rear of the vehicle shall always be marked;
 - (b) Loads projecting laterally beyond the outer edge of the vehicle in such a way that their lateral outer edge is more than 0.40 m from the outer edge of the vehicle's front position (side) light shall be marked at the front at night, and loads projecting in such a way that their lateral outer edge is more than 0.40 m from the outer edge of the vehicle's red rear position (side) light shall be similarly marked at the rear at night.
5. Nothing in paragraph 4 of this Article shall be construed as preventing Contracting Parties or subdivisions thereof from prohibiting, restricting, or subjecting to special authorization, load projections as referred to in the aforesaid paragraph 4.

⁴⁹ See also Point 22 of the Annex of the European Agreement.

ARTICLE 30 bisCarriage of passengers

Passengers shall not be carried in such numbers or in such a way as to interfere with driving or obstruct the driver's view.

ARTICLE 31

Behaviour in case of accident

1. Without prejudice to the provisions of domestic legislation concerning the obligation to assist the injured, every driver or other road-user involved in a traffic accident shall:

(a) Stop as soon as he can do so without causing an additional danger to traffic;

(b) Endeavour to ensure traffic safety at the site of the accident and, if a person has been killed or seriously injured in the accident, to prevent, insofar as such action does not affect traffic safety, any change in conditions at the site, including the disappearance of traces which might be useful for determining responsibilities;

(c) If so requested by other persons involved in the accident, identify himself to them;

(d) If a person has been injured or killed in the accident, notify the police and remain on the scene of the accident or return to it and wait there until the arrival of the police, unless he has been authorized by the police to leave or has to assist the injured or to receive attention himself.

⁵⁰ See footnote.

2. Contracting Parties or subdivisions thereof may, under their domestic legislation, refrain from imposing the provision of paragraph 1 (d) of this Article in cases where no serious injury has been caused and none of the persons involved requests that the police should be notified.

ARTICLE 32

Rules of the use of lamps

1. Between nightfall and dawn and in any other circumstances when visibility is inadequate on account, for example, of fog, snowfall or heavy rain, the following lamps shall be lit on a moving vehicle:

(a) On power-driven vehicles and mopeds the driving lamp(s) or passing lamp(s) and the rear position lamp(s), according to the equipment prescribed by the present Convention for the vehicle of each category;

(b) On trailers, front position lamps, if such lamps are required according to Annex 5, paragraph 30, of this Convention, and not less than two rear position lamps.

⁵⁰ Additional subparagraph introduced in the Annex of the European Agreement (see Point 24).

2. Driving lamps shall be switched off and replaced by passing lamps:
 - (a) In built-up areas where the road is adequately lighted and outside built-up areas where the carriageway is continuously lighted and the lighting is sufficient to enable the driver to see clearly for an adequate distance and to enable other road-users to see the vehicle far enough away;
 - (b) When a driver is about to pass another vehicle, so as to prevent dazzle far enough away to enable the driver of the other vehicle to proceed easily and without danger;
 - (c) In any other circumstances in which it is necessary to avoid dazzling other road-users or the users of a waterway or railway running alongside the road.
3. When, however, a vehicle is following closely behind another vehicle, driving lamps may be used to give a luminous warning as referred to in Article 28, paragraph 2, of the intention to overtake.
4. Fog lamps may be lit only in thick fog, falling snow, heavy rain or similar conditions and, as regards front fog lamps, as a substitute for passing lamps. Domestic legislation may authorize the simultaneous use of front fog lamps and passing lamps and the use of front fog lamps on narrow, winding roads.
5. On vehicles equipped with front position lamps, such lamps shall be used together with the driving lamps, the passing lamps or the front fog lamps.
6. During the day, a motorcycle moving on the road shall display at least one passing lamp to the front and a red lamp to the rear. Domestic legislation may permit the use of daytime running lamps instead of passing lamps.
7. Domestic legislation may make it compulsory for drivers of motor vehicles to use during the day either passing lamps or daytime running lamps. Rear position lamps shall in this case be used together with the front lamps.
8. Between nightfall and dawn and in any other circumstances when visibility is inadequate, the presence of power-driven vehicles and their trailers standing or parked on a road shall be indicated by front and rear position lamps. In thick fog, falling snow, heavy rain or similar conditions passing lamps or front fog lamps may be used. Rear fog lamps may in these conditions be used as a supplement to the rear position lamps.
9. Notwithstanding the provisions of paragraph 8 of this Article, within a built-up area the front and rear position lamps may be replaced by parking lamps, provided that:
 - (a) The vehicle does not exceed 6 m in length and 2 m in width;
 - (b) No trailer is coupled to the vehicle;
 - (c) The parking lamps are placed on that side of the vehicle which is furthest from the carriageway edge alongside which the vehicle is standing or parked.
10. Notwithstanding the provisions of paragraphs 8 and 9 of this Article, a vehicle may be standing or parked without any lamps lit:
 - (a) On a road lit in such a way that the vehicle is clearly visible at an adequate distance;

- (b) Away from the carriageway and hard shoulder;
 - (c) In the case of mopeds and two-wheeled motorcycles without a side-car which are not equipped with batteries, at the extreme edge of a carriageway in a built-up area.
11. Domestic legislation may grant exemptions from the provisions of paragraphs 8 and 9 of this Article for vehicles standing or parked in streets in built-up areas where there is very little traffic.
12. Reversing lamps may be used only when the vehicle is reversing or about to reverse.
13. Hazard warning signal may be used only to warn other road-users of a particular danger:
- (a) When a vehicle which has broken down or has been involved in an accident cannot be moved immediately, so that it constitutes an obstacle to other road-users;
 - (b) When indicating to other road-users the risk of an imminent danger.
14. Special warning lamps:
- (a) Displaying a blue light may be used only on priority vehicles when carrying out an urgent mission or when in other cases it is necessary to give warning to other road-users of the presence of the vehicle;
 - (b) Displaying an amber light may be used only when the vehicles genuinely assigned to the specific tasks for which they were equipped with the special warning lamp or when the presence of such vehicles on the road constitutes a danger or inconvenience to other road-users.
- The use of warning lamps displaying other colours may be authorized by domestic legislation.
15. In no circumstances shall a vehicle display a red light to the front or white light to the rear, subject to the exemptions mentioned in Annex 5, paragraph 61. A vehicle shall not be modified or lamps added to it in a way which could conflict with this requirement.

ARTICLE 33

Rules of lighting of other vehicles than mentioned in Article 32 and of certain road users

1. Every vehicle or combination of vehicles to which the provisions of Article 32 of this Convention do not apply shall, when on a road between nightfall and dawn, show at least one white or selective-yellow light to the front and at least one red light to the rear. Where there is only one lamp at the front or only one lamp at the rear, the lamp shall be placed on the centre-line of the vehicle or on the side opposite to that corresponding to the direction of traffic.
- (a) Handcarts, i.e., carts drawn or pushed by hand, shall show at least one white or selective-yellow light to the front and at least one red light to the rear. These two lights may be emitted by a single lamp placed on the side opposite to that corresponding to the direction of traffic. Lights shall not be required on handcarts not exceeding 1 m in width.
 - (b) Animal-drawn vehicles shall show two white or selective-yellow lights to the front, and two red lights to the rear. Domestic legislation may, however, make it permissible for such

vehicles to show only one white or selective-yellow light to the front and only one red light to the rear. The lamps shall in both cases be placed on the side opposite to that corresponding to the direction of traffic. If the lamps described above cannot be attached to the vehicle, they may be carried by an escort walking immediately alongside the vehicle, on the opposite side to that corresponding to the direction of traffic. Furthermore, animal-drawn vehicles shall be fitted with two red reflex-reflectors to the rear, as close as possible to the outer edges of the vehicle. Lights shall not be required on animal-drawn vehicles not exceeding 1 m in width. However, a single reflex-reflector shall in this case be placed at the rear on the side opposite to that corresponding to the direction of traffic, or centrally.

2. (a) When moving along the carriageway by night:
 - (i) Groups of pedestrians led by a person in charge or forming a procession, must display, on the side opposite to that appropriate to the direction of traffic, at least one white or selective-yellow light to the front and a red light to the rear, or an amber light in both directions;
 - (ii) Drivers of draught, pack or saddle animals, or of cattle, must display, on the side opposite to that appropriate to the direction of traffic, at least one white or selective--yellow light to the front and a red light to the rear, or an amber light in both directions. These lights may be displayed by a single device.
- (b) The lights referred to in subparagraph (a) of this paragraph are, however, not required within an appropriately lit built-up area.

ARTICLE 34

Exemptions

1. When warned of the approach of a priority vehicle by its special luminous and audible warning devices every road-user shall leave room clear for it to pass on the carriageway and shall, if necessary, stop.
2. Domestic legislation may provide that drivers of priority vehicles shall not be bound, when warning of their movement is given by the vehicle's special warning devices, and provided that they do not endanger other road-users, to comply with all or any of the provisions of this Chapter II other than those of Article 6, paragraph 2.⁵¹
3. Domestic legislation may determine to what extent persons working on the construction, repair or maintenance of the road, including the drivers of equipment used for such work, shall not be bound, provided they take the necessary precautions, to observe the provisions of this Chapter II during their work.
4. For the purpose of overtaking or passing the equipment referred to in paragraph 3 of this Article while it is engaged in work on the road, the drivers of other vehicles may, to the extent necessary and on conditions that they take all due precautions, disregard the requirements of Articles 11 and 12 of this Convention.

⁵¹ See also Point 26 of the Annex of the European Agreement.

Chapter III**CONDITIONS FOR THE ADMISSION OF MOTOR VEHICLES
AND TRAILERS TO INTERNATIONAL TRAFFIC****ARTICLE 35****Registration**

1. (a) In order to be entitled to the benefits of this Convention, every motor vehicle in international traffic, and every trailer, other than a light trailer, coupled to a motor vehicle shall be registered by a Contracting Party or a subdivision thereof, and the driver of the motor vehicle shall carry a valid certificate of such registration issued either by a competent authority of such Contracting Party or subdivision thereof or on behalf and by authorization of such Contracting Party or subdivision thereof by an association duly empowered thereto by that Contracting Party or subdivision thereof. This certificate, to be known as the registration certificate, shall bear the following particulars at least:

A serial number, to be known as the registration number, composed in the manner indicated in Annex 2 to this Convention;

The date of first registration of the vehicle;

The full name and home address of the holder of the certificate;

The name or the trademark of the maker of the vehicle;

The serial number of the chassis (the maker's production or serial number);

In the case of a vehicle intended for the carriage of goods, the permissible maximum mass;

In the case of a vehicle intended for the carriage of goods, the unladen mass;

The period of validity, if not unlimited.

The particulars entered in the certificate shall either be in Latin characters or so-called English cursive script only, or be repeated in that form.

(b) Contracting Parties or subdivisions thereof may, however, decide that the year of manufacture, instead of the date of first registration, shall be entered on certificates issued in their territories.

(c) In the case of motor vehicles of categories A and B as defined in Annexes 6 and 7 to this Convention and, if possible, for other motor vehicles:

(i) The certificate shall be headed with the distinguishing sign of the State of registration as defined in Annex 3 to this Convention;

(ii) The letters A, B, C, D, E, F, G and H respectively shall be placed before or after the eight items of information which are required under subparagraph (a) of this paragraph, to be shown on all registration certificates;

- (iii) The words *Certificat d'immatriculation* in French may be placed either before or after the title of the certificate in the national language (or languages) of the country of registration.

(d) For trailers, including semi-trailers, imported temporarily into a country by a mode of transport other than road transport, a photocopy of the registration certificate, certified as a true copy by the authority which issued the certificate, shall be considered sufficient.

2. Notwithstanding the provisions of paragraph 1 of this Article, an articulated vehicle which is not disassembled while in international traffic shall be entitled to the benefits of the provisions of this Convention even if it has only a single registration and a single certificate for the drawing vehicle and semi-trailer composing it.

3. Nothing in this Convention shall be construed as limiting the right of Contracting Parties or subdivisions thereof to require, in the case of a vehicle in international traffic which is not registered in the name of a person travelling in it, proof of the driver's right to be in possession of the vehicle.

4. It is recommended that Contracting Parties should set up, if they have not already done so, a service responsible for keeping, at the national or regional level, a record of motor vehicles brought into use and a centralized record, for each vehicle, of the particulars entered in each certificate of registration.

ARTICLE 36

Registration number

1. Every motor vehicle in international traffic shall display its registration number at the front and at the rear; motorcycles, however, shall only be required to display this number at the rear.
2. Every registered trailer in international traffic shall display its registration number at the rear. Where a motor vehicle draws one or more trailers, the sole trailer or the last trailer, if not registered, shall display the registration number of the drawing vehicle.
3. The composition of the registration number referred to in this Article, and the manner of displaying it, shall conform to the provisions of Annex 2 to this Convention.

ARTICLE 37

Distinguishing sign of the State of registration

1. (a) Every motor vehicle in international traffic shall display at the rear, in addition to its registration number, the distinguishing sign of the State in which it is registered.
(b) This sign may either be placed separately from the registration plate or may be incorporated into the registration plate.
(c) When the distinguishing sign is incorporated into the registration plate, it must also appear on the front registration plate of the vehicle if such is obligatory.

2. Every trailer coupled to a motor vehicle and required under Article 36 of this Convention to display a registration number at the rear shall also display at the rear, either separately from its registration plate or incorporated into it, the distinguishing sign of the State where the registration number was assigned.

The provisions of this paragraph shall be applicable even if the trailer is registered in a State other than the State of registration of the motor vehicle to which it is coupled; if the trailer is not registered, it shall display at the rear the distinguishing sign of the State of registration of the drawing vehicle except when it is travelling in that State.

3. The composition of the distinguishing sign, and the manner of displaying it or its incorporation into the registration plate, shall conform to the conditions laid down in Annexes 2 and 3 to this Convention.

ARTICLE 38

Identification marks

Every motor vehicle and every trailer in international traffic shall bear the identification marks specified in Annex 4 to this Convention.

ARTICLE 39

Technical requirements and inspection of vehicles

1. Every motor vehicle, every trailer and every combination of vehicles in international traffic shall satisfy the provisions of Annex 5 to this Convention. It shall also be in good working order.

2. Domestic legislation shall require periodic technical inspections of:

(a) Motor vehicles used for the carriage of persons and having more than eight seats in addition to the driver's seat;

(b) Motor vehicles used for the carriage of goods whose permissible maximum mass exceeds 3,500 kg and trailers designed to be coupled to such vehicles.

3. Domestic legislation shall, as far as possible, extend the provision of paragraph 2 to the other categories of vehicles.

⁵² See footnote.

ARTICLE 40

Transitional provision

1. For a period of 10 years from the entry into force of this Convention in accordance with Article 47, paragraph 1, trailers in international traffic, whatever their permissible maximum mass, shall be entitled to the benefits of the provisions of this Convention even if they are not registered.

⁵² Additional paragraphs introduced in the Annex of the European Agreement (see Point 26 bis).

2. The registration certificate shall conform with the provisions of the amendment to Article 35, paragraph 1 within five years from the date of its entry into force. Certificates issued during that period shall be mutually recognized until the expiry date inscribed therein.

⁵³ See footnote.

Chapter IV

DRIVERS OF MOTOR VEHICLES

ARTICLE 41

Driving permits

*(The present text is applicable until 28 March 2011 at the latest (see new article 43),
the new text is reproduced in dark blue following the present Article)*

1. (a) Every driver of a motor vehicle must hold a driving permit;
- (b) Contracting Parties undertake to ensure that driving permits are issued only after verification by the competent authorities that the driver possesses the required knowledge and skill;
- (c) Domestic legislation must lay down requirements for obtaining a driving permit;
- (d) Nothing in this Convention shall be construed as preventing Contracting Parties or subdivisions thereof from requiring driving permits for other power-driven vehicles and mopeds.

2. Contracting Parties shall recognize:

- (a) Any domestic permit drawn up in their national language or in one of their national languages, or, if not drawn up in such a language, accompanied by a certified translation;
- (b) Any domestic permit conforming to the provisions of Annex 6 to this Convention;
and
- (c) Any international permit conforming to the provisions of Annex 7 to this Convention;

as valid for driving in their territories a vehicle coming within the categories covered by the permit, provided that the permit is still valid and that it was issued by another Contracting Party or subdivision thereof or by an association duly empowered thereto by such other Contracting Party. The provisions of this paragraph shall not apply to learner-driver permits.

[*ex paragraph 3 deleted*]

⁵³ Additional paragraph introduced in the Annex of the European Agreement (see Point 26 ter).

3. Notwithstanding the provisions of the preceding paragraph:

(a) Where the validity of the driving permit is made subject by special endorsement to the condition that the holder shall wear certain devices or that the vehicle shall be equipped in a certain way to take account of the driver's disability, the permit shall not be recognized as valid unless those conditions are observed;

(b) Contracting Parties may refuse to recognize the validity in their territories of driving permits held by persons under eighteen years of age;

(c) Contracting Parties may refuse to recognize the validity in their territories, for the driving of motor vehicles or combinations of vehicles in categories C, D and E referred to in Annexes 6 and 7 to this Convention, of driving permits held by persons under twenty-one years of age.

4. Contracting Parties may introduce in their domestic legislation a subdivision of the categories of vehicles referred to in Annexes 6 and 7 of this Convention. If the driving permit is restricted to certain vehicles within a category, a numeral shall be added to the letter of the category and the nature of the restriction shall be indicated in the driving permit.

5. For the purpose of the application of paragraph 2 and subparagraph 3 (c) of this Article:

(a) A motor vehicle of the category B referred to in Annexes 6 and 7 to this Convention may be coupled to a light trailer; it may also be coupled to a trailer whose permissible maximum mass exceeds 750 kg but does not exceed the unladen mass of the motor vehicle if the combined permissible maximum mass of the vehicles so coupled does not exceed 3,500 kg;

(b) A motor vehicle of the category C, or of the category D referred to in Annexes 6 and 7 to this Convention may be coupled to a light trailer without the resultant combination ceasing to belong to category C or category D.

6. An international permit shall be issued only to the holder of a domestic permit for the issue of which the minimum conditions laid down in this Convention have been fulfilled. It shall not be valid after the expiry of the corresponding domestic permit, the number of which shall be entered in the international permit.

7. The provisions of this Article shall not require Contracting Parties:

(a) To recognize the validity of domestic or international permits issued in the territory of another Contracting Party to persons who had their normal residence in their territories at the time of such issue or whose normal residence has been transferred to their territories since such issue; or

(b) To recognize the validity of permits as aforesaid issued to drivers whose normal residence at the time of such issue was not in the territory in which the permit was issued or who since such issue have transferred their residence to another territory.

ARTICLE 41

Driving permits

(Provisions applicable from 29 March 2011 (see new article 43))

1. (a) Every driver of a motor vehicle must hold a driving permit;
 - (b) Contracting Parties undertake to ensure that driving permits are issued only after verification by the competent authorities that the driver possesses the required knowledge and skills; the persons authorized to check if drivers have the necessary knowledge and skills must have appropriate qualifications; the contents and procedure of both theoretical and practical exams are regulated by national legislation;
 - (c) Domestic legislation must lay down requirements for obtaining a driving permit. In particular, it shall specify the minimum ages for holding a permit, the medical conditions to be fulfilled and the conditions for passing the theoretical and practical exams;
 - (d) Nothing in this Convention shall be construed as preventing Contracting Parties or subdivisions thereof from requiring driving permits for other power-driven vehicles and mopeds.
2. (a) Contracting Parties shall recognize:
 - (i) Any domestic permit conforming to the provisions of Annex 6 to this Convention;
 - (ii) Any international permit conforming to the provisions of Annex 7 to this Convention, on condition that it is presented with the corresponding domestic driving permit,

as valid for driving in their territories a vehicle coming within the categories covered by the permits, provided that the permits are still valid and that they were issued by another Contracting Party or subdivision thereof or by an association duly empowered thereto by such other Contracting Party or one of its subdivisions;
- (b) Driving permits issued by a Contracting Party shall be recognized in the territory of another Contracting Party until this territory becomes the place of normal residence of their holder;
- (c) The provisions of this paragraph shall not apply to learner-driver permits.
3. Domestic legislation may limit the period of validity of a domestic driving permit. The period of validity of an international permit shall be either no more than three years after the date of issue or until the date of expiry of the domestic driving permit, whichever is earlier.
4. Notwithstanding the provisions of paragraphs 1 and 2:
 - (a) Where the validity of the driving permit is made subject by special endorsement to the condition that the holder shall wear certain devices or that the vehicle shall be equipped in a certain way to take account of the driver's disability, the permit shall not be recognized as valid unless those conditions are observed;

(b) Contracting Parties may refuse to recognize the validity in their territories of driving permits held by persons under eighteen years of age;

(c) Contracting Parties may refuse to recognize the validity in their territories, for the driving of motor vehicles or combinations of vehicles in categories C, D, CE and DE referred to in Annexes 6 and 7 to this Convention, of driving permits held by persons under twenty-one years of age.

5. An international permit shall be issued only to the holder of a domestic permit for the issue of which the minimum conditions laid down in this Convention have been fulfilled. An international driving permit shall only be issued by the Contracting Party in whose territory the holder has his normal residence and which issued the domestic driving permit or which recognized the driving permit issued by another Contracting Party; it shall not be valid for use in that territory.

6. The provisions of this Article shall not require Contracting Parties:

(a) To recognize the validity of domestic permits issued in the territory of another Contracting Party to persons who had their normal residence in their territories at the time of such issue or whose normal residence has been transferred to their territories since such issue;

(b) To recognize the validity of domestic permits issued to drivers whose normal residence at the time of such issue was not in the territory in which the permit was issued or who since such issue have transferred their residence to another territory.

ARTICLE 42

Suspension of the validity of driving permits

1. Contracting Parties or subdivisions thereof may withdraw from a driver the right to use his domestic or international driving permit in their territories if he commits in their territories a breach of their regulations rendering him liable under their legislations to the forfeiture of his permit. In such a case the competent authority of the Contracting Party or subdivision thereof withdrawing the right to use the permit may:

(a) Withdraw and retain the permit until the period of the withdrawal of use expires or until the holder leaves its territory, whichever is the earlier;

(b) Notify the withdrawal of the right to use the permit to the authority by or on behalf of which the permit was issued;

(c) In the case of an international permit, enter in the space provided for the purpose an endorsement to the effect that the permit is no longer valid in its territories;

(d) Where it has not applied the procedure for which provision is made in subparagraph (a) of this paragraph, supplement the communication referred to in subparagraph (b) by requesting the authority which issued the permit, or on behalf of which the permit was issued, to notify the person concerned of the decision taken with regard to him.

2. Contracting Parties shall endeavour to notify the persons concerned of the decisions communicated to them in accordance with the procedure laid down in paragraph 1 (d) of this Article.

3. Nothing in this Convention shall be construed as prohibiting Contracting Parties or subdivisions thereof from preventing a driver holding a domestic or international driving permit from driving if it is evident or proved that his condition is such that he is unable to drive safely or if the right to drive has been withdrawn from him in the State in which he has his normal residence.

ARTICLE 43

Transitional provisions

1. Contracting Parties shall issue domestic driving permits in accordance with the new provisions of Annex 6 at the latest five years after their entry into force. Domestic driving permits issued in accordance with the earlier provisions of Article 41, Article 43 and Annex 6 to this Convention prior to the expiry of this period shall be recognized as long as they are valid.
2. Contracting Parties shall issue international driving permits in accordance with the new provisions of Annex 7 at the latest five years after their entry into force. International driving permits issued in accordance with the earlier provisions of Article 41, Article 43 and Annex 7 to this Convention prior to the expiry of this period shall be valid according to the conditions defined in Article 41, paragraph 3.

Chapter V

CONDITIONS FOR THE ADMISSION OF CYCLES AND MOPEDS TO INTERNATIONAL TRAFFIC

ARTICLE 44

1. Cycles without an engine in international traffic shall:
 - (a) Have an efficient brake;
 - (b) Be equipped with a bell capable of being heard at a sufficient distance, and carry no other audible warning device;
 - (c) Be equipped with a red reflecting device at the rear and with devices such that the cycle can show a white or selective-yellow light to the front and a red light to the rear.

⁵⁴ See footnote.

2. In the territory of Contracting Parties which have not, in accordance with Article 54, paragraph 2, of this Convention, made a statement to the effect that they treat mopeds as motorcycles, mopeds in international traffic shall:

- (a) Have two independent brakes;
- (b) Be equipped with a bell or some other audible warning device capable of being heard at a sufficient distance;

⁵⁴ Additional subparagraph introduced in the Annex of the European Agreement (see Point 27).

- (c) Be equipped with an effective exhaust silencer;
- (d) Be so equipped that they can show a white or selective-yellow light to the front and a red light and a red reflex-reflector to the rear;⁵⁵
- (e) Display the identification mark specified in Annex 4 to this Convention.

⁵⁶ See footnote.

3. In the territories of Contracting Parties which have, in accordance with Article 54, paragraph 2, of this Convention, declared that they treat mopeds as motorcycles, the conditions to be fulfilled by mopeds in order to be admitted to international traffic shall be those laid down for motorcycles in Annex 5 to this Convention.

Chapter VI

FINAL PROVISIONS

ARTICLE 45

1. This Convention shall be open at United Nations Headquarters, New York, until 31 December 1969 for signature by all States Members of the United Nations or of any of the specialized agencies or of the International Atomic Energy Agency or Parties to the Statute of the International Court of Justice, and by any other State invited by the General Assembly of the United Nations to become a Party to the Convention.
2. This Convention is subject to ratification. The instruments of ratification shall be deposited with the Secretary-General of the United Nations.
3. This Convention shall remain open for accession by any of the States referred to in paragraph 1 of this Article. The instruments of accession shall be deposited with the Secretary-General.
4. On signing this Convention or on depositing its instrument of ratification or accession, each State shall notify the Secretary-General of the distinguishing sign it has selected for display in international traffic on vehicles registered by it, in accordance with Annex 3 to this Convention. By a further notification addressed to the Secretary-General, any State may change a distinguishing sign it has previously selected.

ARTICLE 46

1. Any State may, at the time of signing or ratifying this Convention, or of acceding thereto, or at any time thereafter, declare by notification addressed to the Secretary-General that the Convention shall become applicable to all or any of the territories for the international relations of which it is responsible. The Convention shall become applicable to the territory or territories

⁵⁵ See also Point 27 of the Annex of the European Agreement.

⁵⁶ Additional subparagraph introduced in the Annex of the European Agreement (see Point 27).

named in the notification thirty days after the receipt of the notification by the Secretary-General or on the date of entry into force of the Convention for the State making the notification, whichever is the later.

2. Any State which has made a declaration under paragraph 1 of this Article may at any time thereafter declare by notification addressed to the Secretary-General that the Convention shall cease to be applicable to the territory named in the notification and the Convention shall cease to be applicable to such territory one year from the date of receipt by the Secretary-General of the notification.

3. A State making a notification under paragraph 1 of this Article shall notify the Secretary-General of the distinguishing sign or signs it has selected for display in international traffic on vehicles registered in the territory or territories concerned, in accordance with Annex 3 to this Convention. By a further notification addressed to the Secretary-General, any State may change a distinguishing sign it has previously selected.

ARTICLE 47

1. This Convention shall enter into force twelve months after the date of deposit of the fifteenth instrument of ratification or accession.

2. For each State ratifying or acceding to this Convention after the deposit of the fifteenth instrument of ratification or accession, the Convention shall enter into force twelve months after the date of deposit by such State of its instrument of ratification or accession.

ARTICLE 48

Upon its entry into force, this Convention shall terminate and replace, in relations between the Contracting Parties, the International Convention relative to Motor Traffic and the International Convention relative to Road Traffic, both signed at Paris on 24 April 1926, the Convention on the Regulation of Inter-American Automotive Traffic, opened for signature at Washington on 15 December 1943, and the Convention on Road Traffic, opened for signature at Geneva on 19 September 1949.

ARTICLE 49

1. After this Convention has been in force for one year, any Contracting Party may propose one or more amendments to the Convention. The text of any proposed amendment, accompanied by an explanatory memorandum, shall be transmitted to the Secretary-General, who shall communicate it to all Contracting Parties. The Contracting Parties shall have the opportunity of informing him within a period of twelve months following the date of its circulation whether they (a) accept the amendment; or (b) reject the amendment; or (c) wish that a conference be convened to consider the amendment. The Secretary-General shall also transmit the text of the proposed amendment to all other States referred to in Article 45, paragraph 1 of this Convention.

2. (a) Any proposed amendment communicated in accordance with the preceding paragraph shall be deemed to be accepted if within the period of twelve months referred to in the preceding paragraph less than one third of the Contracting Parties inform the Secretary-General that they either reject the amendment or wish that a conference be convened to consider it. The Secretary-General shall notify all Contracting Parties of each acceptance or rejection of any proposed amendment and of requests that a conference be convened. If the total number of such rejections

and requests received during the specified period of twelve months is less than one third of the total number of Contracting Parties, the Secretary-General shall notify all Contracting Parties that the amendment will enter into force six months after the expiry of the period of twelve months referred to in the preceding paragraph for all Contracting Parties except those which, during the period specified, have rejected the amendment or requested the convening of a conference to consider it.

(b) Any Contracting Party which, during the said period of twelve months, has rejected a proposed amendment or requested the convening of a conference to consider it may at any time after the end of such period notify the Secretary-General that it accepts the amendment, and the Secretary-General shall communicate such notification to all the other Contracting Parties. The amendment shall enter into force, with respect to the Contracting Parties which have notified their acceptance, six months after receipt by the Secretary-General of their notification.

3. If a proposed amendment has not been accepted in accordance with paragraph 2 of this Article and if within the period of twelve months specified in paragraph 1 of this Article less than half of the total number of the Contracting Parties inform the Secretary-General that they reject the proposed amendment and if at least one third of the total number of Contracting Parties, but not less than ten, inform him that they accept it or wish a conference to be convened to consider it, the Secretary-General shall convene a conference for the purpose of considering the proposed amendment or any other proposal which may be submitted to him in accordance with paragraph 4 of this Article.

4. If a conference is convened in accordance with paragraph 3 of this Article, the Secretary-General shall invite to it all States referred to in Article 45, paragraph 1 of this Convention. He shall request all States invited to the conference to submit to him, at least six months before its opening date, any proposals which they may wish the conference to consider in addition to the proposed amendment and shall communicate such proposals, at least three months before the opening date of the conference, to all States invited to the conference.

5. (a) Any amendment to this Convention shall be deemed to be accepted if it has been adopted by a two thirds majority of the States represented at the conference, provided that such majority comprises at least two thirds of Contracting Parties represented at the conference. The Secretary-General shall notify all Contracting Parties of the adoption of the amendment, and the amendment shall enter into force twelve months after the date of his notification for all Contracting Parties except those which during that period have notified the Secretary-General that they reject the amendment.

(b) A Contracting Party which has rejected an amendment during the said period of twelve months may at any time notify the Secretary-General that it accepts the amendment, and the Secretary-General shall communicate such notification to all the other Contracting Parties. The amendment shall enter into force, with respect to the Contracting Party which has notified its acceptance, six months after receipt by the Secretary-General of the notification or at the end of the said period of twelve months, whichever is later.

6. If the proposed amendment is not deemed to be accepted pursuant to paragraph 2 of this Article and if the conditions prescribed by paragraph 3 of this Article for convening a conference are not fulfilled, the proposed amendment shall be deemed to be rejected.

ARTICLE 50

Any Contracting Party may denounce this Convention by written notification addressed to the Secretary-General. The denunciation shall take effect one year after the date of receipt by the Secretary-General of such notification.

ARTICLE 51

This Convention shall cease to be in force if the number of Contracting Parties is less than five for any period of 12 consecutive months.

ARTICLE 52

Any dispute between two or more Contracting Parties which relates to the interpretation or application of this Convention and which the Parties are unable to settle by negotiation or other means of settlement may be referred, at the request of any of the Contracting Parties concerned, to the International Court of Justice for decision.

ARTICLE 53

Nothing in this Convention shall be construed as preventing a Contracting Party from taking such action, compatible with the provisions of the Charter of the United Nations and limited to the exigencies of the situation, as it considers necessary to its external or internal security.

ARTICLE 54

1. Any State may, at the time of signing this Convention or of depositing its instrument of ratification or accession, declare that it does not consider itself bound by Article 52 of this Convention. Other Contracting Parties shall not be bound by Article 52 with respect to any Contracting Party which has made such a declaration.

2. At the time of depositing its instrument of ratification or accession, any State may, by notification addressed to the Secretary-General, declare that for the purposes of the application of the Convention it treats mopeds as motorcycles (Article 1 (n)).

By notification addressed to the Secretary-General, any State may subsequently at any time withdraw its declaration.

3. The declarations provided for in paragraph 2 of this Article shall become effective six months after the date of receipt by the Secretary-General of notification of them or on the date on which the Convention enters into force for the State making the declaration, whichever is the later.

4. Any modification of a previously selected distinguishing sign notified in conformity with Article 45, paragraph 4, or Article 46, paragraph 3 of this Convention, shall take effect three months after the date on which the Secretary-General receives notification thereof.

5. Reservations to this Convention and its annexes, other than the reservation provided for in paragraph 1 of this Article, shall be permitted on condition that they are formulated in writing and, if formulated before the deposit of the instrument of ratification or accession, are confirmed in that instrument. The Secretary-General shall communicate such reservations to all States referred to in Article 45, paragraph 1, of this Convention.

6. Any Contracting Party which has formulated a reservation or made a declaration under paragraphs 1 or 4 of this Article may withdraw it at any time by notification addressed to the Secretary-General.

7. A reservation made in accordance with paragraph 5 of this Article:

(a) Modifies for the Contracting Party which made the reservation the provisions of the Convention to which the reservation relates, to the extent of the reservation;

(b) Modifies those provisions to the same extent for the other Contracting Parties in their relations with the Contracting Party which entered the reservation.

ARTICLE 55

In addition to the declarations, notifications and communications provided for in Articles 49 and 54 of this Convention, the Secretary-General shall notify all the States referred to in Article 45, paragraph 1, of the following:

(a) Signatures, ratifications and accessions under Article 45;

(b) Notifications and declarations under Article 45, paragraph 4, and Article 46;

(c) The dates of entry into force of this Convention in accordance with Article 47;

(d) The date of entry into force of amendments to this Convention in accordance with Article 49, paragraphs 2 and 5;

(e) Denunciations under Article 50;

(f) The determination of this Convention under Article 51.

ARTICLE 56

The original of this Convention, of which the Chinese, English, French, Russian and Spanish texts done in a single copy are equally authentic, shall be deposited with the Secretary-General of the United Nations, who shall send certified true copies thereof to all the States referred to in Article 45, paragraph 1, of this Convention.

IN WITNESS WHEREOF the undersigned Plenipotentiaries,* being duly authorized by their respective Governments, have signed this Convention.

DONE at Vienna this eighth day of November, one thousand nine hundred and sixty-eight.

* See document E/CONF.56/16/Rev.1.

ANNEXES

Annex 1

**EXCEPTIONS TO THE OBLIGATION TO ADMIT MOTOR VEHICLES
AND TRAILERS IN INTERNATIONAL TRAFFIC**

1. Contracting Parties may refuse to admit to their territories in international traffic motor vehicles, trailers or combinations of vehicles whose overall mass or mass per axle or dimensions exceed the limits fixed by their domestic legislations for vehicles registered in their territories. Contracting Parties in whose territories there is international heavy vehicle traffic shall endeavour to conclude regional agreements under which roads in the region, with the exception of minor roads, will be open, in international traffic, to vehicles or combinations of vehicles whose mass and dimensions do not exceed the figures specified in these agreements.
2. For the purposes of paragraph 1 of this Annex, the lateral projection of the following shall not be regarded as projection beyond the permissible maximum width:
 - (a) Tyres, near their point of contact with the ground and connections of tyre-pressure indicators;
 - (b) Anti-skid devices mounted on the wheels;
 - (c) Driving mirrors so designed as to yield both forwards and backwards under moderate pressure so that they no longer project beyond the permissible maximum width;
 - (d) Side direction-indicators and marker lights, provided that such projection does not exceed a few centimetres;
 - (e) Customs seals affixed to the load, and devices for the securing and protection of such seals.
3. Contracting Parties may refuse to admit to their territories in international traffic the following combinations of vehicles insofar as the use of such combinations is prohibited by their domestic legislations:
 - (a) Motorcycles with trailers;
 - (b) Combinations of vehicles consisting of a motor vehicle and several trailers;
 - (c) Articulated vehicles used for passenger transport.
4. Contracting Parties may refuse to admit to their territories in international traffic the motor vehicles and trailers to which the exceptions specified in paragraph 60 of Annex 5 to this Convention are applicable.
5. Contracting Parties may refuse to admit to their territories in international traffic mopeds and motorcycles whose drivers and passengers, if any, are not equipped with protective helmets.
6. Contracting Parties may make it a condition for the admission to their territories in international traffic of any motor vehicle other than a two-wheeled moped or a two-wheeled motorcycle without side-car, that the motor vehicle shall carry a device referred to in paragraph 56 of Annex 5 to this Convention, to give warning of the danger constituted by the vehicle's presence when it is stationary on the carriageway.

7. Contracting Parties may make it a condition for the admission to certain difficult roads or to certain areas of difficult terrain in their territories in international traffic of motor vehicles with a permissible maximum mass exceeding 3,500 kg, that such vehicles shall comply with the special requirements laid down in their domestic legislations concerning the admission to such roads or areas of vehicles of the same permissible maximum mass registered by them.

⁵⁷ *See footnote*

8. Contracting Parties may refuse to admit to their territories in international traffic any motor vehicle equipped with passing lamps with asymmetric beams if such beams have not been adapted to suit the direction of traffic in their territories.

9. Contracting Parties may refuse to admit to their territories in international traffic any motor vehicle, or any trailer coupled to a motor vehicle, which displays a distinguishing sign other than one of those prescribed in Article 37 of this Convention. Contracting Parties may not refuse admission to a vehicle which has a distinguishing sign placed separately from the registration plate in conformity with the provisions of this Convention substituting a distinguishing sign which is incorporated into the registration plate and which is not in conformity with the provisions of this Convention.

⁵⁷ Additional paragraph introduced in the Annex of the European Agreement (see Point 28).

Annex 2

REGISTRATION NUMBER AND PLATE OF MOTOR VEHICLES AND TRAILERS IN INTERNATIONAL TRAFFIC

1. The registration number referred to in Articles 35 and 36 of this Convention shall be composed either of numerals or of numerals and letters. The numerals shall be Arabic numerals and the letters shall be in capital Latin characters. Other numerals or characters may, however, be used, but if so the registration number shall be repeated in Arabic numerals and in capital Latin characters.

2. The registration number shall be so composed and displayed as to be legible in normal daylight at a distance of at least 40 m by an observer placed on the axis of the vehicle, the vehicle being stationary; Contracting Parties may, however, in respect of the vehicles they register, reduce this minimum legibility distance for motorcycles and for special categories of motor vehicle on which it would be difficult to fit registration numbers of sufficient size to be legible at 40 m.

3. When the registration number is displayed on a plate, this plate shall be flat and fixed in a vertical or nearly vertical position and at right angles to the vehicle's median longitudinal plane.

When the number is displayed or painted on the vehicle, the surface on which it is displayed or painted shall be flat and vertical, or nearly flat and vertical, and at right angles to the vehicle's median longitudinal plane.

4. Without prejudice to the provisions of Annex 5, paragraph 61 (g) of this Convention, the background of the registration plate on which the registration number and, where applicable, the distinguishing sign of the State in which the vehicle is registered, possibly completed by the flag or emblem according to the conditions defined in Annex 3, is displayed, may be of a retro-reflective material.

5. The background of the part of the registration plate on which the distinguishing sign is incorporated shall be of the same material as that used for the background of the part on which the registration number is marked.

Annex 3**DISTINGUISHING SIGN OF MOTOR VEHICLES AND TRAILERS
IN INTERNATIONAL TRAFFIC**

1. The distinguishing sign referred to in Article 37 of this Convention shall consist of one to three letters in capital Latin characters.
2. When the distinguishing sign is displayed separately from the registration plate, it must conform to the following conditions:
 - (a) The letters shall have a height of at least 0.08 m and their strokes a width of at least 0.01 m. The letters shall be in black on a white background having the shape of an ellipse with the major axis horizontal. The white background may be of a retro-reflective material;
 - (b) When the distinguishing sign consists of only one letter, the major axis of the ellipse may be vertical;
 - (c) The distinguishing sign shall not be affixed in such a way that it could be confused with the registration number or impair its legibility;
 - (d) On motorcycles and their trailers, the dimensions of the axes of the ellipse shall be at least 0.175 m and 0.115 m. On other motor vehicles and their trailers, the dimensions of the axes of the ellipse shall be at least:
 - (i) 0.24 m and 0.145 m if the distinguishing sign comprises three letters;
 - (ii) 0.175 m and 0.115 m if the distinguishing sign comprises less than three letters.
3. When the distinguishing sign is incorporated into the registration plate(s), the following conditions shall apply:
 - (a) The letters shall have a height of at least 0.02 m, taking as a reference a registration plate of 0.11 m.;
 - (b)
 - (i) The distinguishing sign of the State of registration, which may be supplemented where applicable by the flag or emblem of the State or the emblem of the regional economic integration organization to which the country belongs, shall be displayed on the far left or right of the rear registration plate, but preferably on the left or the far upper left on plates where the number takes up two lines;
 - (ii) When, in addition to the distinguishing sign, a non-numerical symbol and/or a flag and/or a regional or local emblem is displayed on the registration plate, the distinguishing sign of the State of registration shall obligatorily be placed on the far left of the plate;
 - (c) The flag or emblem supplementing where applicable the distinguishing sign of the State of registration shall be positioned so that it cannot impair the legibility of the distinguishing sign and shall preferably be placed above it;

(d) The distinguishing sign of the State of registration shall be positioned so as to be easily identifiable and so that it cannot be confused with the registration number or impair its legibility. The distinguishing sign shall therefore be at least of a different colour from the registration number, or have a different background colour to that reserved for the registration number, or be clearly separated, preferably by a line, from the registration number;

(e) For the registration plates of motorcycles and their trailers and/or for registration plates taking up two lines, the size of the letters of the distinguishing sign as well as, where applicable, the size of the national flag or emblem of the State of registration or the symbol of the regional economic integration organization which the country belongs to may be appropriately modified;

(f) The provisions of this paragraph shall apply according to the same principles to the front registration plate of the vehicle when this plate is obligatory.

4. The relevant provisions of Annex 2, paragraph 3, shall apply to the distinguishing sign.

Annex 4**IDENTIFICATION MARKS OF MOTOR VEHICLES AND TRAILERS
IN INTERNATIONAL TRAFFIC**

1. The identification marks shall comprise:
 - (a) In the case of a motor vehicle:
 - (i) The name or the trade mark of the maker of the vehicle;
 - (ii) On the chassis or, in the absence of a chassis, on the body, the maker's production or serial number;
 - (iii) On the engine, the engine number if such a number is placed on it by the maker;
 - (b) In the case of a trailer, the information referred to in subparagraphs (i) and (ii) above;
 - (c) In the case of a moped, the cylinder capacity and the mark "CM".
2. The marks mentioned in paragraph 1 of this Annex shall be placed in accessible positions and shall be easily legible; in addition, they shall be such that they cannot be easily altered or removed. The letters and figures included in the marks shall be either in Latin characters or in English cursive script and in Arabic numerals only, or be repeated in that form.

Annex 5

TECHNICAL CONDITIONS CONCERNING MOTOR VEHICLES AND TRAILERS

1. Without prejudice to the provisions of Article 3, paragraph 2 (a) and Article 39, paragraph 1 of this Convention any Contracting Party may, with respect to motor vehicles which it registers and to trailers which it allows on the road under its domestic legislation, lay down rules which supplement, or are stricter than, the provisions of this Annex. All vehicles in international traffic must meet the technical requirements in force in their country of registration when they first entered into service.
2. For the purposes of this Annex, the term "trailer" applies only to a trailer designed to be coupled to a motor vehicle.
3. Contracting Parties which, in conformity with Article 1, subparagraph (n), of this Convention, have declared that they wish to treat as motorcycles three-wheeled vehicles the unladen mass of which does not exceed 400 kg, shall make such vehicles subject to the rules laid down in this Annex either for motorcycles or for other motor vehicles.

CHAPTER I

Braking

4. For the purposes of this chapter:
 - (a) The term "wheels of one axle" means wheels which are arranged symmetrically, or largely symmetrically, in relation to the vehicle's median longitudinal plane, even if they are not placed on the same axle (a tandem axle is counted as two axles);
 - (b) The term "service brake" means the device normally used to slow down and stop the vehicle;
 - (c) The term "parking brake" means the device used to hold the vehicle stationary in the driver's absence, or, in the case of trailers, when the trailer is uncoupled;
 - (d) The term "secondary (emergency) brake" means the device designed to slow down and stop the vehicle in the event of failure of the service brake.
- A. **Braking of motor vehicles other than motorcycles**
5. Every motor vehicle other than a motorcycle shall have brakes which can be easily operated by the driver when in his driving position. These brakes shall be capable of performing the following three braking functions:
 - (a) A service brake capable of slowing down the vehicle and of stopping it safely, rapidly and effectively, whatever its conditions of loading and whatever the upward or downward gradient of the road on which it is moving;
 - (b) A parking brake capable of holding the vehicle stationary, whatever its conditions of loading, on a noticeable upward or downward gradient, the operative surfaces of the brake being held in the braking position by a device whose action is purely mechanical;

(c) A secondary (emergency) brake capable of slowing down and stopping the vehicle, whatever its conditions of loading, within a reasonable distance, even in the event of failure of the service brake.

6. Subject to the provisions of paragraph 5 of this Annex, the devices providing the three braking functions (service brake, secondary brake and parking brake) may have parts in common; combination of the controls shall be permitted only on condition that at least two separate controls remain.

7. The service brake shall act on all the wheels of the vehicle.

8. The secondary (emergency) brake shall be capable of acting on at least one wheel on each side of the vehicle's median longitudinal plane; the same provision shall apply to the parking brake.

9. The service brake and the parking brake shall act on braking surfaces permanently connected to the wheels through components of adequate strength.

10. No braking surface shall be capable of being disconnected from the wheels. Nevertheless, such disconnection shall be permitted in the case of some of the braking surfaces, on condition:

(a) That it is only momentary, as for example, during a change of gear;

(b) That so far as concerns the parking brake, it can be effected only by the action of the driver; and

(c) That so far as concerns the service or secondary (emergency) brake, braking remains possible with the efficiency prescribed in paragraph 5 of this Annex.

10 bis. All vehicle equipment contributing to braking shall be so designed and constructed that the efficacy of the service brake is ensured after prolonged and repeated use.

10 ter. The service braking action shall be properly distributed and synchronized among the various axles of the vehicle.

10 quater. If the control of the service brake is assisted, partially or totally, by an energy source other than the muscular energy of the driver, it shall be possible to stop the vehicle within a reasonable distance even in the event of the failure of the energy source.

B. Braking of trailers

11. Without prejudice to the provisions of paragraph 17 (c) of this Annex, every trailer, with the exception of a light trailer, shall have brakes as follows:

(a) A service brake capable of slowing down the vehicle and of stopping it safely, rapidly and effectively, whatever its conditions of loading and whatever the upward or downward gradient of the road on which it is moving;

(b) A parking brake capable of holding the vehicle stationary, whatever its conditions of loading, on a noticeable upward or downward gradient, the operative surfaces of the brake being held in the braking position by a device whose action is purely mechanical. This provision shall

not apply to trailers which cannot be uncoupled from the drawing vehicle without the use of tools, provided that the requirements for parking brakes are satisfied for the combination of vehicles.

12. The devices providing the two braking functions (service and parking) may have parts in common.

13. The service brake shall act on all the wheels of the trailer. The braking action shall be properly distributed and synchronized among the various axles of the trailer.

14. The service brake shall be capable of being brought into action by the service brake control of the drawing vehicle; if, however, the permissible maximum mass of the trailer does not exceed 3,500 kg, the brakes may be such as to be brought into action, while the trailer is in motion, only by the trailer moving up on the drawing vehicle (overrun braking).

15. The service brake and the parking brake shall act on braking surfaces permanently connected to the wheels through components of adequate strength.

16. The braking devices shall be such that the trailer is stopped automatically if the coupling device breaks while the trailer is in motion. This requirement shall not apply, however, to trailers with only one axle or with two axles less than 1 m apart, provided that their permissible maximum mass does not exceed 1,500 kg and, except for semi-trailers, that they are fitted, in addition to the coupling device, with a secondary attachment.

C. Braking of combinations of vehicles

17. In addition to the provisions of parts A and B of this Chapter relating to separate vehicles (motor vehicles and trailers), the following provisions shall apply to combinations of such vehicles:

(a) The braking devices on each of the component vehicles shall be compatible;

(b) The service braking action shall be properly distributed and synchronized between the various axles of the combination;

(c) The permissible maximum mass of a trailer without a service brake shall not exceed half of the sum of the unladen mass of the drawing vehicle and the mass of the driver.

D. Braking of motorcycles

18. (a) Every motorcycle shall be equipped with two brakes, one of which acts at least on the rear wheel or wheels and the other at least on the front wheel or wheels; if a side-car is attached to a motorcycle, braking of the side-car wheel shall not be required. These braking devices shall be capable of slowing down the motorcycle and of stopping it safely, rapidly and effectively, whatever its conditions of loading and whatever the upward or downward gradient of the road on which it is moving;

(b) In addition to the provisions of subparagraph (a) of this paragraph, motorcycles having three wheels symmetrically arranged in relation to the vehicle's median longitudinal plane shall be equipped with a parking brake that fulfils the conditions stated in paragraph 5 (b) of this Annex.

CHAPTER II

Vehicle lighting and light-signalling devices

19. For the purposes of this chapter, the term:

“Driving lamp” means the lamp used to illuminate the road over a long distance ahead of the vehicle;

“Passing lamp” means the lamp used to illuminate the road ahead of the vehicle without causing undue dazzle or inconvenience to oncoming drivers and other road-users;

“Front position lamp” means the lamp used to indicate the presence and the width of the vehicle when viewed from the front;

“Rear position lamp” means the lamp used to indicate the presence and the width of the vehicle when viewed from the rear;

“Stop lamp” means the lamp used to indicate to other road-users to the rear of the vehicle that the driver is applying the service brake;

“Front fog lamp” means the lamp used to improve the illumination of the road in case of thick fog, falling snow, heavy rain or similar conditions;

“Rear fog lamp” means the lamp used to make the vehicle more visible from the rear in case of thick fog, falling snow, heavy rain or similar conditions;

“Reversing lamp” means the lamp used to illuminate the road to the rear of the vehicle and provide a warning signal to other road-users that the vehicle is reversing or about to reverse;

“Direction-indicator lamp” means the lamp used to indicate to other road-users that the driver intends to change direction to the right or to the left;

“Parking lamp” means the lamp used to indicate the presence of a parked vehicle; it may replace the front and rear position lamps;

“Marker lamp” means the lamp positioned near the outer edge of the overall width and as near as possible to the top of the vehicle for the purpose of clearly indicating the overall width. This signal complements the position lamps for some motor vehicles and trailers by drawing particular attention to their size;

“Hazard warning signal” means the signal given by the simultaneous functioning of all the direction-indicator lamps;

“Side lamp” means the lamp installed on the side of the vehicle so as to indicate its presence when viewed from the side;

“Special warning lamp” means the lamp intended to indicate either priority vehicles or a vehicle or a group of vehicles whose presence on the road requires other road-users to take special precautions, in particular, convoys of vehicles, vehicles of exceptional size and road construction or maintenance vehicles or equipment;

“Rear registration plate illuminating device” means the device ensuring the illumination of the rear registration plate; it may be made up of several optical elements;

“Daytime (running) lamp” means a lamp intended to improve the daytime conspicuity and visibility of the front of a vehicle in running use;

“Reflex-reflector” means a device used to indicate the presence of a vehicle by reflection of light emanating from a light source unconnected with that vehicle;

“Illuminating surface” means the orthogonal projection, in a transverse vertical plane, of the effective surface from which the light is emitted. For a reflex-reflector, the effective surface is the visible surface of the reflex-reflecting optical unit.

20. The colours of lights mentioned in this chapter should, as far as possible, be in accordance with the definitions given in the appendix to this Annex.

21. With the exception of motorcycles, every motor vehicle capable of exceeding 40 km (25 miles) per hour on level road shall be equipped in front with an even number of white or selective-yellow driving lamps capable of adequately illuminating the road at night in clear weather [*words deleted*]. The outer edges of the illuminating surfaces of the driving lamps shall in no case be closer to the extreme outer edge of the vehicle than the outer edges of the illuminating surfaces of the passing lamps.

22. With the exception of motorcycles, every motor vehicle capable of exceeding 10 km (6 miles) per hour on level road shall be equipped in front with an even number of white or selective-yellow passing lamps capable of adequately illuminating the road at night in clear weather. A motor vehicle shall be equipped with a device such that no more than two passing lamps may be lit simultaneously. Passing lamps shall be so adjusted as to comply with the definition in paragraph 19 of this Annex.

23. Every motor vehicle other than a two-wheeled motorcycle without side-car shall be equipped in front with two white front position lamps; however, selective yellow shall be permitted for front position lamps incorporated in driving lamps or passing lamps which emit a selective-yellow beam. These front position lamps, when they are the only lamps switched on at the front of the vehicle, shall be visible at night in clear weather without causing undue dazzle or inconvenience to other road-users.

24. (a) Every motor vehicle other than a two-wheeled motorcycle without side-car shall be equipped at the rear with an even number of red rear position lamps visible at night in clear weather without causing undue dazzle or inconvenience to other road-users;

(b) Every trailer shall be equipped at the rear with an even number of red rear position lamps visible at night in clear weather without causing undue dazzle or inconvenience to other road-users. It shall, however, be permissible for a trailer whose overall width does not exceed 0.80 m to be equipped with only one such lamp if the trailer is coupled to a two-wheeled motorcycle without side-car.

25. Every motor vehicle or trailer displaying a registration number at the rear shall be equipped with a lighting device such that the number is legible at night in clear weather.

26. The electrical connections on all motor vehicles (including motorcycles) and on all combinations consisting of a motor vehicle and one or more trailers shall be such that the driving lamps, passing lamps, front fog lamps and front position lamps of the motor vehicle and the lighting device referred to in paragraph 25 above cannot be switched on unless the rearmost rear position lamps of the motor vehicle or combination of vehicles are switched on as well.

Rear fog lamps shall be able to be switched on only if the driving lamps, the passing lamps or the front fog lamps are switched on.

However, this provision shall not apply to driving lamps or passing lamps when they are used to give the luminous warning referred to in Article 32, paragraph 3, of this Convention. In addition, the electrical connections shall be such that the front position lamps of the motor vehicle are always switched on when the passing lamps, driving lamps or fog lamps are on.

27. Every motor vehicle other than two-wheeled motorcycles without side-car shall be equipped at the rear with at least two red reflex-reflectors of other than triangular form. When illuminated by the driving, passing or fog lamps of another vehicle, the reflex-reflectors shall be visible to the driver of that vehicle at night in clear weather.

28. Every trailer shall be equipped at the rear with at least two red reflex-reflectors. These reflex-reflectors shall have the shape of an equilateral triangle with one vertex uppermost and one side horizontal. No signal lamp shall be placed inside the triangle. These reflex-reflectors shall meet the requirements for visibility laid down in paragraph 27 above. However, trailers with an overall width not exceeding 0.80 m may be equipped with only one reflex-reflector if they are coupled to a two-wheeled motorcycle without side-car.

29. Every trailer shall be equipped at the front with two white reflex-reflectors of other than triangular form. These reflex-reflectors shall meet the *[words deleted]* visibility requirements laid down in paragraph 27 above.

30. A trailer shall be equipped at the front with two white front position lamps if its width exceeds 1.60 m. The front position lamps thus prescribed shall be fitted as near as possible to the extreme outer edge of the trailer.

31. With the exception of two-wheeled motorcycles with or without side-car, every motor vehicle capable of exceeding 25 km (15 miles) per hour on a level road shall be equipped at the rear with at least two red stop lamps, the luminous intensity of which is markedly higher than that of the rear position lamps. The same provision shall apply to every trailer which is the last vehicle in a combination of vehicles.

32. Subject to the possibility that exemption from all or some of these obligations may be granted in respect of mopeds by Contracting Parties which, in conformity with Article 54, paragraph 2, of the Convention, have declared that they treat mopeds as motorcycles:

(a) Every two-wheeled motorcycle with or without side-car shall be equipped with one or two passing lamps satisfying the conditions regarding colour and visibility laid down in paragraph 22 above;

(b) Every two-wheeled motorcycle with or without side-car capable of exceeding 40 km (25 miles) per hour on a level road shall be equipped, in addition to the passing lamp, with at least one driving lamp satisfying the conditions regarding colour and visibility laid down in paragraph 21 above. If such a motorcycle has more than one driving lamp, these lamps shall be situated as close together as possible.

(c) *[deleted]*

33. Every two-wheeled motorcycle without side-car may be equipped at the front with one or two front position (side) lamps satisfying the conditions regarding colour and visibility laid down in paragraph 23 above. If such a motorcycle has two front position (side) lamps, these lamps shall be situated as close together as possible.

34. Every two-wheeled motorcycle without side-car shall be equipped at the rear with one rear position side lamp satisfying the conditions regarding colour and visibility laid down in paragraph 24 (a) above.

35. Every two-wheeled motorcycle without side-car shall be equipped at the rear with a non-triangular reflex-reflector satisfying the conditions regarding colour and visibility laid down in paragraph 27 above.

36. Subject to the possibility for Contracting Parties which, in conformity with Article 54, paragraph 2, have declared that they treat mopeds as motorcycles, to exempt two-wheeled mopeds with or without side-cars from this obligation, every two-wheeled motorcycle with or without side-car shall be equipped with a stop lamp conforming to the provisions of paragraph 31 above.

37. Without prejudice to the provisions concerning lamps and devices prescribed for two-wheeled motorcycles without side-car, any side-car attached to a two-wheeled motorcycle shall be equipped at the front with a front position (side) lamp satisfying the conditions regarding colour and visibility laid down in paragraph 23 above, and at the rear with a rear position (side) lamp satisfying the conditions regarding colour and visibility laid down in paragraph 24 (a) above and with a reflex-reflector satisfying the conditions regarding colour and visibility laid down in paragraph 27 above. The electrical connections shall be such that the front position (side) lamp and rear position (side) lamp of the side-car are switched on at the same time as the rear position (side) lamp of the motorcycle. *[Last sentence deleted]*

38. Motor vehicles with three wheels placed symmetrically in relation to the vehicle's median longitudinal plane, which are treated as motorcycles pursuant to Article 1, subparagraph (n), of the Convention, shall be equipped with the devices prescribed in paragraphs 21, 22, 23, 24 (a), 27 and 31 above. However, on an electric vehicle the width of which does not exceed 1.30 m and the speed of which does not exceed 40 km (25 miles) per hour a single driving lamp and a single passing lamp are sufficient.

39. Every motor vehicle, except a moped, and every trailer shall be equipped with fixed direction-indicators with flashing amber lights, fitted on the vehicle in even numbers and visible by day and by night to road-users affected by the vehicle's movements.

40. If front fog lamps are fitted on a motor vehicle they shall emit white or selective-yellow light, be two or, in the case of a motorcycle, one in number and be placed in such a way that no point on their illuminating surface is above the highest point on the illuminating surface of the passing lamps.

41. No reversing lamp shall cause undue dazzle or inconvenience to other road-users. If reversing lamps are fitted on a motor vehicle they shall emit white or selective-yellow light. These lamps shall be lit only when the reverse gear is engaged.
42. No lamps, other than direction-indicator lamps and special warning lamps, shall emit a winking or flashing light. Side lamps may wink at the same time as direction-indicator lamps.
- 42 bis. Special warning lamps shall emit a winking or flashing light. Colours of these lights should conform to the provisions of Article 32, paragraph 14.
- 42 ter. Every motor vehicle except motorcycles and every trailer shall be so equipped that they can emit a hazard warning signal.
- 42 quater. If rear fog lamps are fitted on a motor vehicle or a trailer they shall be red.
- 42 quinquies. Every motor vehicle and every trailer more than 6 m long shall be fitted with amber side reflex-reflectors.
- 42 sexties. Every motor vehicle and trailer more than 1.80 m wide may be fitted with marker lamps. Such lamps shall be mandatory if the width of a motor vehicle or trailer exceeds 2.10 m. If these lamps are used, there shall be at least two of them and they shall emit white or amber light towards the front and red light towards the rear.
- 42 septies. Every motor vehicle and trailer may be fitted with side lamps. If such lamps are fitted they shall emit amber light.
43. For the purposes of the provisions of this Annex:
- (a) Any combination of two or more lamps, whether identical or not, but having the same function and the same colour of light, shall be deemed to be a single lamp;
- (b) A single illuminating surface in the shape of a band shall be deemed to be two or an even number of lamps if it is placed symmetrically to the median longitudinal plane of the vehicle. The illumination of such a surface shall be provided by at least two light sources placed as close as possible to its ends.
44. Lamps on a given vehicle having the same function and facing in the same direction, shall be of the same colour. Lamps and reflex-reflectors which are of even number shall be placed symmetrically in relation to the vehicle's median longitudinal plane, except on vehicles with an asymmetrical external shape. The intensity of the lamps in each pair shall be substantially the same.
45. Lamps of different kinds, and, subject to the provisions of other paragraphs of this Chapter, lamps and reflex-reflectors, may be grouped or incorporated in the same device, provided that each of these lamps and reflectors complies with the applicable provisions of this Annex.

CHAPTER III

Other requirements

Steering mechanism

46. Every motor vehicle shall be equipped with a strong steering mechanism which will allow the driver to change the direction of the vehicle, easily, quickly and surely.

Driving (rear-view) mirror

47. Every motor vehicle shall be equipped with one or more driving (rear-view) mirrors; the number, dimensions and arrangement of these mirrors shall be such as to enable the driver to see the traffic to the rear of his vehicle.

Audible warning device

48. Every motor vehicle shall be equipped with at least one audible warning device of sufficient power. The sound emitted by the warning device shall be continuous and uniform, but not strident. Priority vehicles and public passenger-transport vehicles may have additional audible warning devices which are not subject to these requirements.

Windscreen-wiper

49. Every motor vehicle having a windscreen of such dimensions and shape that the driver cannot normally see the road ahead from his driving position except through the transparent part of the windscreen, shall be equipped with at least one efficient and strongly built windscreen-wiper in an appropriate position, the functioning of which does not require constant action by the driver.

Windscreen-washer

50. Every motor vehicle required to be equipped with at least one windscreen-wiper shall also be equipped with a windscreen-washer.

Windscreen and windows

51. On all motor vehicles and on all trailers:

(a) Transparent substances forming part of the vehicle's bodywork, including the windscreen and any interior partition, shall be such that in case of breakage, the risk of physical injury will be minimized;

(b) The transparent parts of the windscreen shall be made of a substance whose transparency does not deteriorate; they shall be such that they do not cause any appreciable distortion of objects seen through the windscreen, and that, in case of breakage, the driver still has a sufficiently clear view of the road.

Reversing device

52. Every motor vehicle shall be equipped with a reversing device controlled from the driving position. This device shall not, however, be compulsory on motorcycles or on motor vehicles having three wheels arranged symmetrically in relation to the vehicle's median longitudinal plane unless their permissible maximum mass exceeds 400 kg.

Exhaust silencer

53. Every internal combustion engine used for propelling a motor vehicle shall be equipped with an efficient exhaust silencer.

Tyres

54. The wheels of motor vehicles and of their trailers shall be fitted with pneumatic tyres ensuring a good adhesion, even on a wet road. This provision shall not, however, prevent Contracting Parties from authorizing the use of devices producing results at least equivalent to those obtained with pneumatic tyres.

Speedometer

55. Every motor vehicle capable of exceeding 40 km (25 miles) per hour on a level road shall be equipped with a speedometer; Contracting Parties may, however, exempt certain categories of motorcycles and other light vehicles from this requirement.

Warning device to be carried on motor vehicles

56. The device referred to in Article 23, paragraph 5, of this Convention, and in paragraph 6 of Annex 1 thereto shall be either:

(a) A signplate consisting of an equilateral triangle with a red border and with its interior part either hollow or of a light colour; the red border shall be fitted with a reflectorized strip. It may also have a red fluorescent area and/or be illuminated by transparency; the signplate shall be such that it can be stood firmly in a vertical position; or

(b) Some other equally effective device, prescribed by the legislation of the country in which the vehicle is registered.

Anti-theft device

57. Every motor vehicle shall be fitted with an anti-theft device by means of which one of its essential components can be put out of action or blocked when the vehicle is parked.

Restraining devices

58. Wherever technically practicable all forward-facing seats of vehicles of category B as referred to in Annexes 6 and 7 of this Convention, with the exception of vehicles constructed or used for special purposes as defined by domestic legislation, shall be equipped with approved safety belts or similarly effective approved devices.

General provisions

59. (a) The mechanical parts and equipment of a motor vehicle shall not, so far as this can possibly be avoided, give rise to any danger of fire or explosion; nor shall they cause excessive emission of noxious gases, opaque fumes, smells or noise.

(b) So far as possible, the high-tension ignition device of a motor vehicle shall not cause excessive radio interference.

(c) Every motor vehicle shall be so constructed that the driver's field of vision ahead, and to both right and left, is sufficient to enable him to drive safely.

(d) Motor vehicles and trailers shall, as far as possible, be so constructed and equipped as to reduce the danger to their occupants and to other road-users in case of accident. In particular, they shall have no ornaments or other objects, inside or outside, with unnecessary projections or ridges which may be dangerous to the occupants or other road-users.

(e) Vehicles of which the maximum permitted mass exceeds 3.5 t shall be equipped, as far as possible, with side and rear-under run devices.

CHAPTER IV

Exemptions

60. For domestic purposes, Contracting Parties may grant exemptions from the provisions of this Annex in respect of:

(a) Motor vehicles and trailers which, by virtue of their design, cannot exceed a speed of 30 km (19 miles) per hour on a level road of whose speed is limited by domestic legislation to 30 km per hour;

(b) Invalid carriages, i.e. small motor vehicles specially designed and constructed - and not merely adapted - for use by a person suffering from some physical defect or disability and normally used by that person only;

(c) Vehicles used for experiments whose purpose is to keep up with technical progress and improve road safety;

(d) Vehicles of a special form or type, or which are used for particular purposes under special conditions;

(e) Vehicles adapted for use by handicapped persons,

61. Contracting Parties may also grant exemptions from the provisions of this Annex in respect of vehicles which they register and which may enter international traffic:

(a) By authorizing the use of the colour amber for the front position lamps of motor vehicles and trailers;

(b) As regards the position of lamps on special-purpose vehicles whose external shape is such that the said provisions could not be observed without the use of mounting devices which could easily be damaged or torn off;

(c) As regards trailers, carrying long loads (tree trunks, pipes, etc.), which are not coupled to the drawing vehicle when in movement, but merely attached to it by the load;

(d) By authorizing the emission towards the rear of white light and towards the front of red light for the following equipment:

- Revolving of flashing lamps of priority vehicles;
- Fixed lamps for exceptional loads;
- Side lamps and reflex-reflectors;
- Professional lighted signs on the roof;

(e) By authorizing the emission of blue light towards the front and towards the rear for revolving or flashing lamps;

(f) By authorizing on any side of a vehicle of a special shape or kind or used for special purposes and in special conditions, alternating red retro-reflective or fluorescent and white retro-reflective strips;

(g) By authorizing the emission towards the rear of white or coloured light reflected by figures or letters or by the background of rear registration plates, by distinctive signs or by other distinctive marks required by domestic legislation;

(h) By authorizing the use of the colour red for rearmost lateral reflex-reflectors and side lamps.

CHAPTER V

Transitional provisions

62. Motor vehicles first registered and trailers put into service in the territories of a Contracting Party before the entry into force of this Convention or within the two years following such entry into force shall not be subject to the provisions of this Annex, provided that they satisfy the requirements of parts I, II and III of Annex 6 of the 1949 Convention on Road Traffic.

62 bis. Motor vehicles first registered and trailers put into service in the territory of a Contracting Party before the entry into force of the amendments to this Convention or within the two years following such entry into force should not be subject to the provisions of this Annex, provided that they satisfy the provisions of Annex 5 of the 1968 Convention on Road Traffic in the wording prior to these amendments or other provisions referred to in Chapter V of the said Annex.

Appendix

DEFINITION OF COLOUR FILTERS FOR OBTAINING THE COLOURS REFERRED TO IN THIS ANNEX (TRICHROMATIC COORDINATES)

| | | |
|-------------------------------------|-------------------------------------------------|-------------------------|
| Red | limit towards yellow | $y \leq 0.335$ |
| | limit towards purple ¹ | $z \leq 0.008$ |
| White | limit towards blue | $x \geq 0.310$ |
| | limit towards yellow | $x \leq 0.500$ |
| | limit towards green | $y \leq 0.150 + 0.640x$ |
| | limit towards green | $y \leq 0.440$ |
| | limit towards purple | $y \geq 0.050 + 0.750x$ |
| | limit towards red | $y \geq 0.382$ |
| Amber ² | limit towards yellow ¹ | $y \leq 0.429$ |
| | limit towards red ¹ | $y \geq 0.398$ |
| | limit towards white ¹ | $z \leq 0.007$ |
| Selective yellow ³ | limit towards red ¹ | $y \geq 0.138 + 0.580x$ |
| | limit towards green ¹ | $y \leq 1.29x - 0.100$ |
| | limit towards white ¹ | $y \geq -x + 0.966$ |
| | limit towards spectral value ¹ | $y \leq -x + 0.992$ |
| Blue | limit towards green | $y = 0.065 + 0.805x$ |
| | limit towards white | $y = 0.400 - x$ |
| | limit towards purple | $x = 0.133 + 0.600y$ |

For verifying the colorimetric characteristics of these filters, a source of white light at a colour temperature of 2,854°K (corresponding to illuminant A of the International Commission on Illumination [CIE]) shall be used.

¹ In these cases, different limits have been adopted from those recommended by the CIE, since the supply voltages at the terminals of the lamps with which the lights are fitted vary very considerably.

² Applies to the colour of motor vehicle signs hitherto commonly called "orange" or orange-yellow. Corresponds to a specific part of the "yellow" zone of the triangle of CIE colours.

³ Applies only to passing and driving lights. In the particular case of fog-lights, the selectivity of the colour shall be considered satisfactory if the purity factor is not less than 0.820, the limit towards white $y \geq -x + 0.966$, being in that case $y \geq -x + 0.940$ and $y = 0.440$.

Annex 6**DOMESTIC DRIVING PERMIT**

(NOTE: The present Annex is applicable until 28 March 2011 at the latest (see new article 43). The new text of the Annex applicable from 29 March 2011 is reproduced in dark blue following the present Annex)

1. The domestic driving permit shall take the form of a document.
2. The permit shall be printed in the language or languages prescribed by the authority issuing it or empowered to issue it; it shall, however, bear the title "permis de conduire" in French, with or without the same title in other languages, and the name and/or distinctive sign of the country in which the permit is issued.
3. Entries made on the permit shall either be in Latin characters or English cursive script only, or be repeated in that form.
4. The following particulars appear on the driving permit; they shall be preceded or followed by the numbers 1 to 11.
 1. Surname
 2. First names¹
 3. Date and place of birth²
 4. Address³
 5. Authority issuing the permit
 6. Date and place of issue of the permit
 7. Date of expiry of the validity of the permit⁴
 8. Number of the permit
 9. Signature and/or stamp or seal of the authority issuing the permit
 10. Holder's signature⁵
 11. Category or categories of vehicle and any sub-categories for which the permit is valid with indication of the date of issue of the permit and the dates of expiry of the validity for each of those categories.

In addition, the holder's photograph shall be affixed to the driving permit. It shall be a matter for domestic legislation to determine any additional particulars to be included in the driving permit as well as the format and the material on which the driving permit is printed.

¹ Father's or husband's name may be inserted here.

² If date of birth is unknown, state approximate age on date of issue of permit. If place of birth is unknown, leave blank. Place of birth may be replaced by other particulars determined by domestic legislation.

³ The address is optional.

⁴ This is optional if the validity of the permit is unlimited.

⁵ Or thumbprint.

5. The categories of vehicles for which the driving permit may be valid are the following:
 - A. Motorcycles;
 - B. Motor vehicles, other than those in category A, having a permissible maximum mass not exceeding 3,500 kg and not more than eight seats in addition to the driver's seat;
 - C. Motor vehicles, other than those in category D, whose permissible maximum mass exceeds 3,500 kg;
 - D. Motor vehicles used for the carriage of passengers and having more than eight seats in addition to the driver's seat;
 - E. Combination of vehicles of which the driving vehicle is in a category or categories for which the driver is licensed (B, and/or C and/or D), but which are not themselves in that category or those categories.
6. Domestic legislations may introduce additional categories of vehicles not belonging to the above-mentioned categories A to E, subcategories within categories and combination of categories, which shall be clearly identified in the driving permit.

Annex 6

DOMESTIC DRIVING PERMIT

(New Annex is applicable from 29 March 2011. (see new Article 43))

1. A domestic driving permit shall take the form of a document.
2. The permit may be made of plastic or paper. The preferred format for the plastic permit shall be 54 x 86 mm in size. The preferred colour of the permit shall be pink; the print and spaces for the entries to be made shall be defined by domestic legislation subject to the provisions of paragraphs 6 and 7.
3. On the front side of the permit is the title "Driving Permit" in the domestic language (domestic languages) of the country issuing the permit, as well as the name and/or the distinguishing sign of the country which issued the permit.
4. It is compulsory to indicate in the permit the data listed under the numbers given below:
 1. Family name;
 2. Given name, other names;
 3. Date and place of birth;¹
 - 4.(a) Date of issue;
 - 4.(b) Expiry date;
 - 4.(c) Name or stamp of the authority which issued the permit;
 5. Number of the permit;
 6. Photograph of the holder;
 7. Signature of the holder;
 9. Categories (subcategories) of vehicles for which the permit is valid;
 12. Additional information or limitations for each category (subcategory) of vehicles in coded form.
5. If additional information is required by domestic legislation, it shall be entered on the driving permit under the numbers given below:
 - 4.(d) Identification number for the purposes of registration, other than the number under 5 of paragraph 4;
 8. Place of normal residence;
 10. Date of issue for each category (subcategory) of vehicles;
 11. Expiry date for each category (subcategory) of vehicles;
 13. Information for purposes of registration in the case of a change in country of normal residence;
 14. Information for purposes of registration or other information related to road traffic safety.
6. All the entries on the permit shall be made only in Latin characters. If other characters are used, the entries shall also be transliterated into the Latin alphabet.













¹ The place of birth may be replaced by other particulars defined by domestic legislation.

7. The information under numbers 1-7 in paragraphs 4 and 5 should preferably be on the same side of the permit. The spaces for other data under numbers 8-14 in paragraphs 4 and 5 should be set by domestic legislation. Domestic legislation may also allocate a space on the permit for the inclusion of electronically stored information.
8. The categories of vehicles for which the driving permit may be valid are the following:
- A. Motorcycles;
 - B. Motor vehicles, other than those in category A, having a permissible maximum mass not exceeding 3,500 kg and not more than eight seats in addition to the driver's seat; or motor vehicles of category B coupled to a trailer the permissible maximum mass of which does not exceed 750 kg; or motor vehicles of category B coupled to a trailer the permissible maximum mass of which exceeds 750 kg but does not exceed the unladen mass of the motor vehicle, where the combined permissible maximum mass of the vehicles so coupled does not exceed 3,500 kg;
 - C. Motor vehicles, other than those in category D, having a permissible maximum mass exceeding 3,500 kg; or motor vehicles of category C coupled to a trailer the permissible maximum mass of which does not exceed 750 kg;
 - D. Motor vehicles used for the carriage of passengers and having more than eight seats in addition to the driver's seat; or motor vehicles of category D coupled to a trailer the permissible maximum mass of which does not exceed 750 kg;
 - BE. Motor vehicles of category B coupled to a trailer the permissible maximum mass of which exceeds 750 kg and exceeds the unladen mass of the motor vehicle; or motor vehicles of category B coupled to a trailer the permissible maximum mass of which exceeds 750 kg, where the combined permissible maximum mass of the vehicles so coupled exceeds 3,500 kg;
 - CE. Motor vehicles of category C coupled to a trailer whose permissible maximum mass exceeds 750 kg;
 - DE. Motor vehicles of category D coupled to a trailer whose permissible maximum mass exceeds 750 kg.
9. Under categories A, B, C, CE, D and DE, domestic legislation may introduce the following subcategories of vehicles for which the driving permit may be valid:
- A1. Motorcycles with a cubic capacity not exceeding 125 cm³ and a power not exceeding 11 kW (light motorcycles);
 - B1. Motor tricycles and quadricycles;
 - C1. Motor vehicles, with the exception of those in category D, the permissible maximum mass of which exceeds 3,500 kg but does not exceed 7,500 kg; or motor vehicles of subcategory C1 coupled to a trailer, the permissible maximum mass of which does not exceed 750 kg;

- D1. Motor vehicles used for the carriage of passengers and having more than 8 seats in addition to the driver's seat but not more than 16 seats in addition to the driver's seat; or motor vehicles of subcategory D1 coupled to a trailer, the permissible maximum mass of which does not exceed 750 kg;
- C1E. Motor vehicles of subcategory C1 coupled to a trailer the permissible maximum mass of which exceeds 750 kg but does not exceed the unladen mass of the motor vehicle, where the combined permissible maximum mass of the vehicles so coupled does not exceed 12,000 kg;
- D1E. Motor vehicles of subcategory D1 coupled to a trailer, not used for the carriage of persons, the permissible maximum mass of which exceeds 750 kg but does not exceed the unladen mass of the motor vehicle, where the combined permissible maximum mass of the vehicles so coupled does not exceed 12,000 kg.

10. Domestic legislation may introduce categories and subcategories of vehicle other than those listed above. The designations of such categories and subcategories should not resemble the symbols used in the Convention to designate categories and subcategories of vehicles; another type of print should also be used.

11. The categories (subcategories) of vehicles for which the permit is valid shall be represented by the pictograms in the table below.

| Category code/Pictogram | | Subcategory code/Pictogram | |
|-------------------------|-------------------------------------------------------------------------------------|----------------------------|---------------------------------------------------------------------------------------|
| A |  | A1 |  |
| B |  | B1 |  |
| C |  | C1 |  |
| D |  | D1 |  |
| BE |  | | |
| CE |  | C1E |  |
| DE |  | D1E |  |

Annex 7

INTERNATIONAL DRIVING PERMIT

1. The permit shall be a booklet in format A 6 (148 x 105 mm). The cover shall be grey and the inside pages white.
2. The outside and inside of the front cover shall conform, respectively, to model pages Nos. 1 and 2 below; they shall be printed in the national language, or in at least one of the national languages, of the issuing State. The last two inside pages shall be facing pages conforming to model No. 3 below; they shall be printed in French. The inside pages preceding these two pages shall repeat the first of them in several languages, which must include English, Russian and Spanish.
3. Handwritten or typed entries made on the permit shall be in Latin characters or in English cursive script.
4. Contracting Parties issuing or authorizing the issuance of international driving permits of which the cover is printed in a language other than English, French, Russian or Spanish shall communicate to the Secretary-General of the United Nations the translation into that language of the text of model page No. 3 below.

MODEL PAGE No. 1
(Outside of front cover)

| | |
|-------------------------------------------------------------------------------------|---|
| 1 | |
| International Motor Traffic | |
| INTERNATIONAL DRIVING PERMIT | |
| No. | |
| Convention on Road Traffic of 8 November 1968 | |
| Valid until | 2 |
| Issued by | |
| At | |
| Date | |
| Number of domestic driving permit | |
|  | 3 |

¹ Name of the issuing State and its distinguishing sign as defined in Annex 3.

² Either no more than three years after the date of issue or the date of expiry of the domestic driving permit, whichever is earlier.

³ Signature of the authority or association issuing the permit.

⁴ Seal or stamp of the authority or association issuing the permit.

MODEL 3
Left hand page

(The present Model 3 (Left hand page) is applicable until 28 March 2011 at the latest (see new article 43). The new one applicable from 29 March 2011 is reproduced in dark blue following this page.)

| PARTICULARS CONCERNING THE DRIVER | |
|-----------------------------------------------------------------------------------------------------------------------------------------------------------------------------------------------------------|----|
| Surname | 1. |
| Other names ¹ | 2. |
| Place of birth ² | 3. |
| Date of birth ³ | 4. |
| Home address | 5. |
| CATEGORIES OF VEHICLES FOR WHICH THE PERMIT IS VALID | |
| Motor cycles | A |
| Motor vehicles, other than those in category A, having a permissible maximum <u>mass</u> not exceeding 3,500 kg and not more than eight seats in addition to the driver's seat. | B |
| Motor vehicles used for the carriage of goods and whose permissible maximum <u>mass</u> exceeds 3,500 kg. | C |
| Motor vehicles used for the carriage of passengers and having more than eight seats in addition to the driver's seat. | D |
| Combinations of vehicles of which the drawing vehicle is in a category or categories for which the driver is licensed (B and/or C and/or D), but which are not themselves in that category or categories. | E |
| RESTRICTIVE CONDITIONS OF USE⁵ | |
| | |

¹ Father's or husband's name may be inserted here.

² If the place of birth is unknown, leave blank.

³ If date of birth is unknown, state approximate age on date of issue of permit.

⁴ Seal or stamp of the authority or association issuing the permit. This seal or stamp shall be affixed against categories, A, B, C, D and E only if the holder is licensed to drive vehicles in the category in question.

⁵ For example, "Must wear corrective lenses", "Valid only for driving vehicle No. ...", "Vehicle must be equipped to be driven by a one-legged person".

MODEL 3
Right hand page

(The present Model 3 (Right hand page) is applicable until 28 March 2011 at the latest (see new article 43). The new one applicable from 29 March 2011 is reproduced in dark blue following this page.)

| | | | | | | |
|--------------------------------------------------------------------------------------------------------------------------------------------------------------------------------------------------------------------------------------------------------------------------------------------------------------------------------------------------------------------------------------------------------------------------------------------------------------------------------------------------------------------------------------------------------------------------------------------------------------------------------------------------------|----------------|----------------|----------------|----------------|----------------|------------------------------------------------------------------------------------------------------------------------------------------------------------------------------------------------------------------------------------------------------------------------------------------------------------------------------------------------------------------------------------------------------------------------------------------------------------------------------------------------------------|
| 1. 2. 3. 4. 5. | | | | | | |
| <table border="1" style="width: 100%; border-collapse: collapse;"> <tr><td style="text-align: center; vertical-align: middle;">A⁴</td></tr> <tr><td style="text-align: center; vertical-align: middle;">B⁴</td></tr> <tr><td style="text-align: center; vertical-align: middle;">C⁴</td></tr> <tr><td style="text-align: center; vertical-align: middle;">D⁴</td></tr> <tr><td style="text-align: center; vertical-align: middle;">E⁴</td></tr> </table> | A ⁴ | B ⁴ | C ⁴ | D ⁴ | E ⁴ | <div style="border: 1px solid black; width: 150px; height: 100px; margin: 0 auto; display: flex; align-items: center; justify-content: center;"> Photograph </div> <div style="text-align: center; margin-top: 20px;"> <div style="border: 1px solid black; width: 40px; height: 40px; border-radius: 50%; display: flex; align-items: center; justify-content: center; margin: 0 auto;">4</div> <p style="margin-top: 10px;">Signature of holder⁶</p> </div> |
| A ⁴ | | | | | | |
| B ⁴ | | | | | | |
| C ⁴ | | | | | | |
| D ⁴ | | | | | | |
| E ⁴ | | | | | | |
| <p>DISQUALIFICATIONS:</p> <p>The holder is deprived of the right to drive in the territory of⁷ until⁸ 8</p> <p>At on</p> <p>The holder is deprived of the right to drive in the territory of⁷ until⁸ 8</p> <p>At on</p> | | | | | | |













⁶ Or thumbprint.

⁷ Name of State.

⁸ Signature and seal or stamp of the authority which has invalidated the permit in its territory. If the spaces provided for disqualifications on this page have already been used, any further disqualifications should be entered overleaf.

MODEL 3
Left hand page

(New Model 3 (Left hand page) applicable from 29 March 2011, (see new Article 43))

| PARTICULARS CONCERNING THE DRIVER | | | |
|-------------------------------------------------------------------------------------------------------|-------------------------------------------------------------------------------------|----------------------------|---------------------------------------------------------------------------------------|
| Family name: | | | 1. |
| Given name, other names: | | | 2. |
| Place of birth: ¹ | | | 3. |
| Date of birth: | | | 4. |
| Place of normal residence: ² | | | 5. |
| CATEGORIES AND SUBCATEGORIES OF VEHICLES, WITH THE CORRESPONDING CODES, FOR WHICH THE PERMIT IS VALID | | | |
| Category code/Pictogram | | Subcategory code/Pictogram | |
| A |  | A1 |  |
| B |  | B1 |  |
| C |  | C1 |  |
| D |  | D1 |  |
| BE |  | | |
| CE |  | C1E |  |
| DE |  | D1E |  |
| RESTRICTIVE CONDITIONS OF USE ³ | | | |
| | | | |

¹ The place of birth may be replaced by other particulars defined by domestic legislation.
² To be completed when required by domestic legislation.
³ For example: "Must wear corrective lenses", "Valid only for driving vehicle No.", "Vehicle must be equipped to be driven by a one-legged person".

MODEL 3
Right hand page

(New Model 3 (Right hand page) applicable from 29 March 2011. (see new Article 43))

| | | | | | |
|----------------------------------------------------------------------------------------------------------------------------------------------------------------------------------------------------------------------------------|--------------------|------------------------------------------------------------------------------------------------------------------------------------------------------------------------------------------------------------------------------------------------------------------------------------------------------------------------------------------------------------------------------------------------------------------------------------------------------------------------------------------------------|---------|---------|--|
| 1. | 2. | 3. | 4. | 5. | |
| STAMP ⁴ | STAMP ⁴ | <div style="border: 1px solid black; width: 150px; height: 100px; margin: 0 auto; display: flex; align-items: center; justify-content: center;"> <div style="text-align: center; margin-bottom: 20px;"> <p>photograph</p> </div> <div style="border: 2px solid black; width: 40px; height: 40px; display: flex; align-items: center; justify-content: center; margin: 0 auto;"> 4 </div> </div> <p style="margin-top: 20px;">Signature of the holder</p> | | | |
| A | A1 | | | | |
| B | B1 | | | | |
| C | C1 | | | | |
| D | D1 | | | | |
| BE | | | | | |
| CE | C1E | | | | |
| DE | D1E | | | | |
| DISQUALIFICATIONS: | | | | | |
| The holder is deprived of the right to drive in the territory of ⁵ until ⁶ | | | | | |
| At ⁶ on ⁶ 6 | | | | | |
| | | | | | |
| The holder is deprived of the right to drive in the territory of ⁵ until ⁶ | | | | | |
| At ⁶ on ⁶ 6 | | | | | |

⁴ Seal or stamp of the authority or association issuing the permit. This seal or stamp shall be affixed against the designation of the categories or subcategories only if the holder is licensed to drive the appropriate vehicles.

⁵ Name of State.

⁶ Signature and seal or stamp of the authority which has invalidated the permit in its territory. If the spaces provided for disqualifications on this page have already been used, any further disqualifications should be entered overleaf.

KG

Handwritten signature and date: 05/04/2021

بِسْمِ اللّٰهِ الرَّحْمٰنِ الرَّحِیْمِ



Ministry of Transport and Civil Aviation
Republic of Maldives

ދިވެހިރާއްޖޭގެ ޖަނަވަރީ ޖަމިއްޔާއި ސަލާމަތުގެ ވަޅުމެންގެ ވަޅުމެންގެ ދާއިރާއެއްގެ ގޮތުގައި

ސަރުކާރުގެ ނަންބަރު: 472/57/2021/11

މާލިއްޔާއި ޖަނަވަރީ ޖަމިއްޔާއި ސަލާމަތުގެ ވަޅުމެންގެ ވަޅުމެންގެ ދާއިރާއެއްގެ ގޮތުގައި ސަރުކާރުގެ ނަންބަރު: 472/57/2021/11

މާލިއްޔާއި ޖަނަވަރީ ޖަމިއްޔާއި ސަލާމަތުގެ ވަޅުމެންގެ ވަޅުމެންގެ ދާއިރާއެއްގެ ގޮތުގައި ސަރުކާރުގެ ނަންބަރު: 472/57/2021/11

ދިވެހިރާއްޖޭގެ ޖަނަވަރީ ޖަމިއްޔާއި ސަލާމަތުގެ ވަޅުމެންގެ ވަޅުމެންގެ ދާއިރާއެއްގެ ގޮތުގައި

މާލިއްޔާއި ޖަނަވަރީ ޖަމިއްޔާއި ސަލާމަތުގެ ވަޅުމެންގެ ވަޅުމެންގެ ދާއިރާއެއްގެ ގޮތުގައި ސަރުކާރުގެ ނަންބަރު: 472/57/2021/11

- Article 2 (b) of the Convention
- Article 52 of the Convention

މާލިއްޔާއި ޖަނަވަރީ ޖަމިއްޔާއި ސަލާމަތުގެ ވަޅުމެންގެ ވަޅުމެންގެ ދާއިރާއެއްގެ ގޮތުގައި

22 ސަޅުމެންގެ ނަންބަރު 1442

04 ޖަނަވަރީ 2021

Handwritten signature

މާލިއްޔާއި ޖަނަވަރީ ޖަމިއްޔާއި ސަލާމަތުގެ ވަޅުމެންގެ ވަޅުމެންގެ ދާއިރާއެއްގެ ގޮތުގައި

މާލިއްޔާއި ޖަނަވަރީ ޖަމިއްޔާއި ސަލާމަތުގެ ވަޅުމެންގެ ވަޅުމެންގެ ދާއިރާއެއްގެ ގޮތުގައި

| | |
|---------------------------------------------------------------------------------------|------------------------------|
| މާލިއްޔާއި ޖަނަވަރީ ޖަމިއްޔާއި ސަލާމަތުގެ ވަޅުމެންގެ ވަޅުމެންގެ ދާއިރާއެއްގެ ގޮތުގައި | |
| 1953 ސަޅުމެންގެ ނަންބަރު | Dhumaani ސަޅުމެންގެ ނަންބަރު |
| 8:57 ޖަނަވަރީ 2021 | 5:42 ޖަނަވަރީ 2021 |
| F ސަޅުމެންގެ ނަންބަރު | |
| ސަޅުމެންގެ ނަންބަރު 06-04-2021 | |

މާލިއްޔާއި ޖަނަވަރީ ޖަމިއްޔާއި ސަލާމަތުގެ ވަޅުމެންގެ ވަޅުމެންގެ ދާއިރާއެއްގެ ގޮތުގައި

دیسپتچ پر آڈو ٹیپسٹ ڈیٹا



سٹیج سٹریٹ: 25-L/2021/293

آڈو ٹیپسٹ ڈیٹا سٹریٹ سٹریٹ

ڈیٹا سٹریٹ ڈیٹا سٹریٹ

سٹریٹ ڈیٹا سٹریٹ 57-F/KG/25/2021/36 (20 2021) سٹریٹ

سٹریٹ ڈیٹا سٹریٹ

ڈیٹا سٹریٹ ڈیٹا سٹریٹ 1968 ڈیٹا سٹریٹ ڈیٹا سٹریٹ
ڈیٹا سٹریٹ 1968 ڈیٹا سٹریٹ ڈیٹا سٹریٹ ڈیٹا سٹریٹ
ڈیٹا سٹریٹ ڈیٹا سٹریٹ ڈیٹا سٹریٹ ڈیٹا سٹریٹ

سٹریٹ ڈیٹا سٹریٹ ڈیٹا سٹریٹ ڈیٹا سٹریٹ
ڈیٹا سٹریٹ ڈیٹا سٹریٹ ڈیٹا سٹریٹ ڈیٹا سٹریٹ
ڈیٹا سٹریٹ ڈیٹا سٹریٹ ڈیٹا سٹریٹ ڈیٹا سٹریٹ
ڈیٹا سٹریٹ ڈیٹا سٹریٹ ڈیٹا سٹریٹ ڈیٹا سٹریٹ
ڈیٹا سٹریٹ ڈیٹا سٹریٹ ڈیٹا سٹریٹ ڈیٹا سٹریٹ

ڈیٹا سٹریٹ ڈیٹا سٹریٹ

14 سٹریٹ 1442

26 ڈیٹا 2021



ڈیٹا سٹریٹ

ڈیٹا سٹریٹ ڈیٹا سٹریٹ

| | |
|-----------------------|-------------------|
| ڈیٹا سٹریٹ ڈیٹا سٹریٹ | |
| ڈیٹا سٹریٹ: Dhumaing | ڈیٹا سٹریٹ: 13:08 |
| ڈیٹا سٹریٹ: 27.5.21 | ڈیٹا سٹریٹ: F |
| ڈیٹا سٹریٹ ڈیٹا سٹریٹ | |

ڈیٹا سٹریٹ ڈیٹا سٹریٹ
ڈیٹا سٹریٹ ڈیٹا سٹریٹ
ڈیٹا سٹریٹ ڈیٹا سٹریٹ